



AIRPLANE FLIGHT MANUAL

DA 42 NG

Airworthiness Category : Normal
Requirement : JAR-23
Serial Number : _____
Registration : _____
Doc. No. : 7.01.16-E
Date of Issue : 01-Apr-2012

Signature :

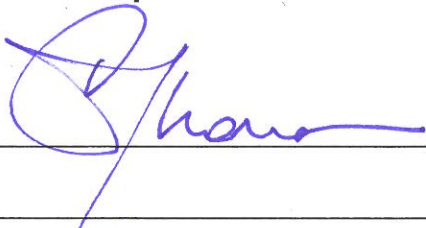

EASA Certification Manager :

European Aviation Safety Agency

Carl Thomas

Stamp :

Certification Manager General Aviation

Date of approval :

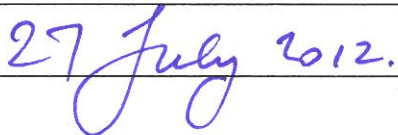

(EASA app. date)



This Airplane Flight Manual is approved with EASA Approval No. 10039193.

- This Airplane Flight Manual is FAA approved for U.S. registered aircraft in accordance
- with the provisions of 14 CFR Section 21.29, and is required by FAA Type Certificate Data
- Sheet no.: A 57CE.

DIAMOND AIRCRAFT INDUSTRIES GMBH
N.A. OTTO-STR. 5
A-2700 WIENER NEUSTADT
AUSTRIA

Intentionally left blank.

FOREWORD

We congratulate you on the acquisition of your new DIAMOND DA 42 NG.

Skillful operation of an airplane increases both safety and the enjoyment of flying. Please take the time therefore, to familiarize yourself with your new DIAMOND DA 42 NG.

This airplane may only be operated in accordance with the procedures and operating limitations of this Airplane Flight Manual.

Before this airplane is operated for the first time, the pilot must familiarize himself with the complete contents of this Airplane Flight Manual.

In the event that you have obtained your DIAMOND DA 42 NG second-hand, please let us know your address, so that we can supply you with the publications necessary for the safe operation of your airplane.

This document is protected by copyright. All associated rights, in particular those of translation, reprinting, radio transmission, reproduction by photo-mechanical or similar means and storing in data processing facilities, in whole or part, are reserved.

Copyright © by: DIAMOND AIRCRAFT INDUSTRIES GMBH
N.A. Otto-Strasse 5
A-2700 Wiener Neustadt, Austria
Phone. : +43-2622-26700
Fax : +43-2622-26780
E-Mail : office@diamond-air.at

0.1 APPROVAL

The content of approved chapters is approved by EASA. All other content is approved by DAI under the authority of EASA DOA No. EASA.21J.052 in accordance with Part 21.

0.2 RECORD OF REVISIONS

All revisions of this manual, with the exception of -

- Temporary Revisions,
- updates of the modification level (Section 1.1),
- updated mass and balance information (Section 6.3),
- updates of the Equipment Inventory (Section 6.5), and
- updates of the List of Supplements (Section 9.2)

must be recorded in the following table.

The new or amended text is indicated by a vertical black line at the left hand side of the revised page, with the revision number and date appearing at the bottom of the page.

If pages are revised which contain information valid for your particular serial number (modification level of the airplane, weighing data, Equipment Inventory, List of Supplements), then this information must be transferred to the new pages in hand-writing.

The cover pages of Temporary Revisions, if applicable, are inserted behind the cover page of this manual. Temporary Revisions are used to provide information on systems or equipment until the next 'permanent' Revision of the Airplane Flight Manual. When a 'permanent' Revision covers a Mandatory or Optional Design Change Advisory (MÄM or OÄM), then the corresponding Temporary Revision is superseded. For example: If Revision 5 covers OÄM 42-039, then the Temporary Revision TR OÄM-42-039 is superseded by the 'permanent' Revision 5.

Page 0 - 2	Rev. 5	10-Jun-2021	Doc. # 7.01.16-E
------------	--------	-------------	------------------

Rev. No.	Reason	Chapter	Page(s)	Date of Revision	EASA Approval No.	Approval Date	Date Inserted	Signature
1	FAA- Approval	0	0-0, 0-0a, 0-3, 0-4	19-Jun-2012	Revision 1 of the AFM Doc. No. 7.01.16-E is approved by EASA under Project No. 0010016964.	27-Jul-2012		
2	<p>MÄM 42-654, 42-685, 42-696, 42-701, 42-757, 42-778, 42-785</p> <p>OÄM 42-055, 42-056, 42-094, 42-119, 42-160/a, 42-179, 42-199, 42-203, 42-204/a & 42-193/a, 42-213, 42-222, 42-224, 42-226, 42-251</p> <p>Corrections</p>	All	All except Cover Page	28-Feb-2014	Revision 2 of the AFM Doc. No. 7.01.16-E is approved under the authority of DOA No. EASA.21J.052	18-Mar-2014		
3	<p>MÄM 42-659, 42-678, 42-759</p> <p>OÄM 42-253, 42-260</p> <p>Corrections</p>	All	All except Cover Page	01-Apr-2014	Revision 3 of the AFM Doc. No. 7.01.16-E is approved by EASA with Approval No.10048945.	05-May-2014		

Rev. No.	Reason	Chapter	Page(s)	Date of Revision	EASA Approval No.	Approval Date	Date Inserted	Signature
4	<p>MÄM 42- -600, -744, -756, -828 & -760, -855, -868, -885, -938/b, -942, -973, -976, -978, -995, -1005, -1030,</p> <p>OÄM 42- -111/a & -158/a & -246, -160/b -168, -169, -170, -173, -178, -194, -208, -209, -213/a, -218, -228, -240, -241, -247, -250, -255, -257, -259, -267, -270, -273, -277, -279, -281, -283, -287, -288, -298, -301, -304,</p> <p>Corrections</p>	All	All except Cover Page	02-Oct-2017	Revision 4 of the AFM Doc. No. 7.01.16-E is approved under the authority of DOA No. EASA.21J.052	27-Oct-2017		

Page 0 - 4	Rev. 5	10-Jun-2021	Doc. # 7.01.16-E
------------	--------	-------------	------------------

Rev. No.	Reason	Chapter	Page(s)	Date of Revision	EASA Approval No.	Approval Date	Date Inserted	Signature
5	<p>MAM 42- -600/b, -1024, -1025,-1034, -1035, -1072,- -1097, -1104, -1114, -1141, -1158, -1179, -1183, -1186, -1191, -1195,</p> <p>OAM 42- -056/a, -160/e, -170/a, -208/a, -228/b , -240/b, -241/a, -250/a, -257/a, -258, -298/b, -303, -304/a, -312, -324/a, -333, -334, -337, -339, -342/a, -343, -349,</p> <p>Corrections</p>	All	All except Cover Page	10-Jun-2021	Revision 5 of the AFM Doc. No. 7.01.16-E is approved under the authority of DOA No. EASA.21J.052	02-Nov-2021		

0.3 LIST OF EFFECTIVE PAGES

Ch.	Page	Date
0	0-0	19-Jun-2012
	0-0a	10-Jun-2021
	0-1	10-Jun-2021
	0-2	10-Jun-2021
	0-3	10-Jun-2021
	0-4	10-Jun-2021
	0-5	10-Jun-2021
	0-6	10-Jun-2021
	0-7	10-Jun-2021
	0-8	10-Jun-2021
	0-9	10-Jun-2021
	0-10	10-Jun-2021
	0-11	10-Jun-2021
	0-12	10-Jun-2021
	0-13	10-Jun-2021
	0-14	10-Jun-2021
	0-15	10-Jun-2021
0-16	10-Jun-2021	

Ch.	Page	Date
1	1-1	10-Jun-2021
	1-2	10-Jun-2021
	1-3	10-Jun-2021
	1-4	10-Jun-2021

Ch.	Page	Date
	1-5	10-Jun-2021
	1-6	10-Jun-2021
	1-7	10-Jun-2021
	1-8	10-Jun-2021
	1-9	10-Jun-2021
	1-10	10-Jun-2021
	1-11	10-Jun-2021
	1-12	10-Jun-2021
	1-13	10-Jun-2021
	1-14	10-Jun-2021
	1-15	10-Jun-2021
	1-16	10-Jun-2021
	1-17	10-Jun-2021
	1-18	10-Jun-2021
	1-19	10-Jun-2021
	1-20	10-Jun-2021
	1-21	10-Jun-2021
	1-22	10-Jun-2021
	1-23	10-Jun-2021
	1-24	10-Jun-2021
	1-25	10-Jun-2021
	1-26	10-Jun-2021



Ch.	Page	Date
2	appr. 2-1	10-Jun-2021
	appr. 2-2	10-Jun-2021
	appr. 2-3	10-Jun-2021
	appr. 2-4	10-Jun-2021
	appr. 2-5	10-Jun-2021
	appr. 2-6	10-Jun-2021
	appr. 2-7	10-Jun-2021
	appr. 2-8	10-Jun-2021
	appr. 2-9	10-Jun-2021
	appr. 2-10	10-Jun-2021
	appr. 2-11	10-Jun-2021
	appr. 2-12	10-Jun-2021
	appr. 2-13	10-Jun-2021
	appr. 2-14	10-Jun-2021
	appr. 2-15	10-Jun-2021
	appr. 2-16	10-Jun-2021
	appr. 2-17	10-Jun-2021
	appr. 2-18	10-Jun-2021
	appr. 2-19	10-Jun-2021
	appr. 2-20	10-Jun-2021
	appr. 2-21	10-Jun-2021
	appr. 2-22	10-Jun-2021
	appr. 2-23	10-Jun-2021
	appr. 2-24	10-Jun-2021
	appr. 2-25	10-Jun-2021
	appr. 2-26	10-Jun-2021
	appr. 2-27	10-Jun-2021

Ch.	Page	Date
2	appr. 2-28	10-Jun-2021
	appr. 2-29	10-Jun-2021
	appr. 2-30	10-Jun-2021
	appr. 2-31	10-Jun-2021
	appr. 2-32	10-Jun-2021
	appr. 2-33	10-Jun-2021
	appr. 2-34	10-Jun-2021
	appr. 2-35	10-Jun-2021
	appr. 2-36	10-Jun-2021
	appr. 2-37	10-Jun-2021
	appr. 2-38	10-Jun-2021
	appr. 2-39	10-Jun-2021
	appr. 2-40	10-Jun-2021
	appr. 2-41	10-Jun-2021
	appr. 2-42	10-Jun-2021
	appr. 2-43	10-Jun-2021
	appr. 2-44	10-Jun-2021
	appr. 2-45	10-Jun-2021
	appr. 2-46	10-Jun-2021
	appr. 2-47	10-Jun-2021
	appr. 2-48	10-Jun-2021

Ch.	Page	Date
3	3-1	10-Jun-2021
	3-2	10-Jun-2021
	3-3	10-Jun-2021
	3-4	10-Jun-2021
	3-5	10-Jun-2021
	3-6	10-Jun-2021
	3-7	10-Jun-2021
	3-8	10-Jun-2021
	3-9	10-Jun-2021
	3-10	10-Jun-2021
	3-11	10-Jun-2021
	3-12	10-Jun-2021
	3-13	10-Jun-2021
	3-14	10-Jun-2021
	3-15	10-Jun-2021
	3-16	10-Jun-2021
	3-17	10-Jun-2021
	3-18	10-Jun-2021
	3-19	10-Jun-2021
	3-20	10-Jun-2021
	3-21	10-Jun-2021
	3-22	10-Jun-2021
	3-23	10-Jun-2021
	3-24	10-Jun-2021
	3-25	10-Jun-2021
	3-26	10-Jun-2021
	3-27	10-Jun-2021

Ch.	Page	Date
3	3-28	10-Jun-2021
	3-29	10-Jun-2021
	3-30	10-Jun-2021
	3-31	10-Jun-2021
	3-32	10-Jun-2021
	3-33	10-Jun-2021
	3-34	10-Jun-2021
	3-35	10-Jun-2021
	3-36	10-Jun-2021
	3-37	10-Jun-2021
	3-38	10-Jun-2021
	3-39	10-Jun-2021
	3-40	10-Jun-2021
	3-41	10-Jun-2021
	3-42	10-Jun-2021
	3-43	10-Jun-2021
	3-44	10-Jun-2021
	3-45	10-Jun-2021
	3-46	10-Jun-2021
	3-47	10-Jun-2021
	3-48	10-Jun-2021
	3-49	10-Jun-2021
	3-50	10-Jun-2021
	3-51	10-Jun-2021
	3-52	10-Jun-2021
	3-53	10-Jun-2021
	3-54	10-Jun-2021

Ch.	Page	Date
3	3-55	10-Jun-2021
	3-56	10-Jun-2021
	3-57	10-Jun-2021
	3-58	10-Jun-2021
	3-59	10-Jun-2021
	3-60	10-Jun-2021
	3-61	10-Jun-2021
	3-62	10-Jun-2021
	3-63	10-Jun-2021
	3-64	10-Jun-2021
	3-65	10-Jun-2021
	3-66	10-Jun-2021
	3-67	10-Jun-2021
	3-68	10-Jun-2021
	3-69	10-Jun-2021
	3-70	10-Jun-2021
	3-71	10-Jun-2021
	3-72	10-Jun-2021
3-73	10-Jun-2021	
3-74	10-Jun-2021	
3-75	10-Jun-2021	
3-76	10-Jun-2021	

Ch.	Page	Date
4A	4A-1	10-Jun-2021
	4A-2	10-Jun-2021
	4A-3	10-Jun-2021
	4A-4	10-Jun-2021
	4A-5	10-Jun-2021
	4A-6	10-Jun-2021
	4A-7	10-Jun-2021
	4A-8	10-Jun-2021
	4A-9	10-Jun-2021
	4A-10	10-Jun-2021
	4A-11	10-Jun-2021
	4A-12	10-Jun-2021
	4A-13	10-Jun-2021
	4A-14	10-Jun-2021
	4A-15	10-Jun-2021
	4A-16	10-Jun-2021
	4A-17	10-Jun-2021
	4A-18	10-Jun-2021
	4A-19	10-Jun-2021
	4A-20	10-Jun-2021
	4A-21	10-Jun-2021
	4A-22	10-Jun-2021
	4A-23	10-Jun-2021
	4A-24	10-Jun-2021
	4A-25	10-Jun-2021
	4A-26	10-Jun-2021
	4A-27	10-Jun-2021

Ch.	Page	Date
4A	4A-28	10-Jun-2021
	4A-29	10-Jun-2021
	4A-30	10-Jun-2021
	4A-31	10-Jun-2021
	4A-32	10-Jun-2021
	4A-33	10-Jun-2021
	4A-34	10-Jun-2021
	4A-35	10-Jun-2021
	4A-36	10-Jun-2021
	4A-37	10-Jun-2021
	4A-38	10-Jun-2021
	4A-39	10-Jun-2021
	4A-40	10-Jun-2021
	4A-41	10-Jun-2021
	4A-42	10-Jun-2021
	4A-43	10-Jun-2021
	4A-44	10-Jun-2021
	4A-45	10-Jun-2021
	4A-46	10-Jun-2021
	4A-47	10-Jun-2021
	4A-48	10-Jun-2021
	4A-49	10-Jun-2021
	4A-50	10-Jun-2021
	4A-51	10-Jun-2021
	4A-52	10-Jun-2021
	4A-53	10-Jun-2021
	4A-54	10-Jun-2021

Ch.	Page	Date
4A	4A-55	10-Jun-2021
	4A-56	10-Jun-2021
	4A-57	10-Jun-2021
	4A-58	10-Jun-2021
	4A-59	10-Jun-2021
	4A-60	10-Jun-2021
	4A-61	10-Jun-2021
	4A-62	10-Jun-2021
	4A-63	10-Jun-2021
	4A-64	10-Jun-2021
	4A-65	10-Jun-2021
	4A-66	10-Jun-2021
	4A-67	10-Jun-2021
	4A-68	10-Jun-2021
4A-69	10-Jun-2021	
4A-70	10-Jun-2021	

Ch.	Page	Date
4B	4B-1	10-Jun-2021
	4B-2	10-Jun-2021
	4B-3	10-Jun-2021
	4B-4	10-Jun-2021
	4B-5	10-Jun-2021
	4B-6	10-Jun-2021
	4B-7	10-Jun-2021
	4B-8	10-Jun-2021
	4B-9	10-Jun-2021
	4B-10	10-Jun-2021
	4B-11	10-Jun-2021
	4B-12	10-Jun-2021
	4B-13	10-Jun-2021
	4B-14	10-Jun-2021
	4B-15	10-Jun-2021
	4B-16	10-Jun-2021
	4B-17	10-Jun-2021
	4B-18	10-Jun-2021
	4B-19	10-Jun-2021
	4B-20	10-Jun-2021
	4B-21	10-Jun-2021
	4B-22	10-Jun-2021
	4B-23	10-Jun-2021
	4B-24	10-Jun-2021
	4B-25	10-Jun-2021
	4B-26	10-Jun-2021
	4B-27	10-Jun-2021

Ch.	Page	Date
4B	4B-28	10-Jun-2021
	4B-29	10-Jun-2021
	4B-30	10-Jun-2021
	4B-31	10-Jun-2021
	4B-32	10-Jun-2021
	4B-33	10-Jun-2021
	4B-34	10-Jun-2021
	4B-35	10-Jun-2021
	4B-36	10-Jun-2021
	4B-37	10-Jun-2021
	4B-38	10-Jun-2021
	4B-39	10-Jun-2021
	4B-40	10-Jun-2021
	4B-41	10-Jun-2021
	4B-42	10-Jun-2021
	4B-43	10-Jun-2021
	4B-44	10-Jun-2021
	4B-45	10-Jun-2021
4B-46	10-Jun-2021	

Ch.	Page	Date
5	5-1	10-Jun-2021
	5-2	10-Jun-2021
	5-3	10-Jun-2021
	5-4	10-Jun-2021
	5-5	10-Jun-2021
	5-6	10-Jun-2021
	5-7	10-Jun-2021
	5-8	10-Jun-2021
	5-9	10-Jun-2021
	5-10	10-Jun-2021
	5-11	10-Jun-2021
	5-12	10-Jun-2021
	5-13	10-Jun-2021
	5-14	10-Jun-2021
	5-15	10-Jun-2021
	5-16	10-Jun-2021
	5-17	10-Jun-2021
	5-18	10-Jun-2021
	5-19	10-Jun-2021
	5-20	10-Jun-2021
	5-21	10-Jun-2021
	5-22	10-Jun-2021
	5-23	10-Jun-2021
	5-24	10-Jun-2021
	5-25	10-Jun-2021
	5-26	10-Jun-2021
	5-27	10-Jun-2021

Ch.	Page	Date
5	5-28	10-Jun-2021
	5-29	10-Jun-2021
	5-30	10-Jun-2021
	5-31	10-Jun-2021
	5-32	10-Jun-2021
	5-33	10-Jun-2021
	5-34	10-Jun-2021
	5-35	10-Jun-2021
	5-36	10-Jun-2021
	5-37	10-Jun-2021
	5-38	10-Jun-2021
	5-39	10-Jun-2021
	5-40	10-Jun-2021
	5-41	10-Jun-2021
5-42	10-Jun-2021	
5-43	10-Jun-2021	
5-44	10-Jun-2021	



Ch.	Page	Date
6	6-1	10-Jun-2021
	6-2	10-Jun-2021
	6-3	10-Jun-2021
	6-4	10-Jun-2021
	6-5	10-Jun-2021
	6-6	10-Jun-2021
	6-7	10-Jun-2021
	6-8	10-Jun-2021
	6-9	10-Jun-2021
	6-10	10-Jun-2021
	6-11	10-Jun-2021
	6-12	10-Jun-2021
	6-13	10-Jun-2021
	6-14	10-Jun-2021
	6-15	10-Jun-2021
	6-16	10-Jun-2021
	6-17	10-Jun-2021
	6-18	10-Jun-2021
	6-19	10-Jun-2021
	6-20	10-Jun-2021
	6-21	10-Jun-2021
	6-22	10-Jun-2021
	6-23	10-Jun-2021
	6-24	10-Jun-2021
	6-25	10-Jun-2021
	6-26	10-Jun-2021
	6-27	10-Jun-2021

Ch.	Page	Date
6	6-28	10-Jun-2021
	6-29	10-Jun-2021
	6-30	10-Jun-2021
	6-31	10-Jun-2021
	6-32	10-Jun-2021
	6-33	10-Jun-2021
	6-34	10-Jun-2021

Ch.	Page	Date
7	7-1	10-Jun-2021
	7-2	10-Jun-2021
	7-3	10-Jun-2021
	7-4	10-Jun-2021
	7-5	10-Jun-2021
	7-6	10-Jun-2021
	7-7	10-Jun-2021
	7-8	10-Jun-2021
	7-9	10-Jun-2021
	7-10	10-Jun-2021
	7-11	10-Jun-2021
	7-12	10-Jun-2021
	7-13	10-Jun-2021
	7-14	10-Jun-2021
	7-15	10-Jun-2021
	7-16	10-Jun-2021
	7-17	10-Jun-2021
	7-18	10-Jun-2021

Ch.	Page	Date
7	7-19	10-Jun-2021
	7-20	10-Jun-2021
	7-21	10-Jun-2021
	7-22	10-Jun-2021
	7-23	10-Jun-2021
	7-24	10-Jun-2021
	7-25	10-Jun-2021
	7-26	10-Jun-2021
	7-27	10-Jun-2021
	7-28	10-Jun-2021
	7-29	10-Jun-2021
	7-30	10-Jun-2021
	7-31	10-Jun-2021
	7-32	10-Jun-2021
	7-33	10-Jun-2021
	7-34	10-Jun-2021
	7-35	10-Jun-2021
	7-36	10-Jun-2021
	7-37	10-Jun-2021
	7-38	10-Jun-2021
	7-39	10-Jun-2021
	7-40	10-Jun-2021
	7-41	10-Jun-2021
	7-42	10-Jun-2021
	7-43	10-Jun-2021
7-44	10-Jun-2021	
7-45	10-Jun-2021	

Ch.	Page	Date
7	7-46	10-Jun-2021
	7-47	10-Jun-2021
	7-48	10-Jun-2021
	7-49	10-Jun-2021
	7-50	10-Jun-2021
	7-51	10-Jun-2021
	7-52	10-Jun-2021
	7-53	10-Jun-2021
	7-54	10-Jun-2021
	7-55	10-Jun-2021
	7-56	10-Jun-2021
	7-57	10-Jun-2021
	7-58	10-Jun-2021
	7-59	10-Jun-2021
	7-60	10-Jun-2021
	7-61	10-Jun-2021
	7-62	10-Jun-2021
	7-63	10-Jun-2021
	7-64	10-Jun-2021
	7-65	10-Jun-2021
	7-66	10-Jun-2021
	7-67	10-Jun-2021
	7-68	10-Jun-2021
	7-69	10-Jun-2021
	7-70	10-Jun-2021
7-71	10-Jun-2021	
7-72	10-Jun-2021	

Ch.	Page	Date
7	7-73	10-Jun-2021
	7-74	10-Jun-2021
	7-75	10-Jun-2021
	7-76	10-Jun-2021
	7-77	10-Jun-2021
	7-78	10-Jun-2021
	7-79	10-Jun-2021
	7-80	10-Jun-2021
	7-81	10-Jun-2021
	7-82	10-Jun-2021
	7-83	10-Jun-2021
	7-84	10-Jun-2021
	7-85	10-Jun-2021
	7-86	10-Jun-2021
	7-87	10-Jun-2021
	7-88	10-Jun-2021
	7-89	10-Jun-2021
7-90	10-Jun-2021	

Ch.	Page	Date
8	8-1	10-Jun-2021
	8-2	10-Jun-2021
	8-3	10-Jun-2021
	8-4	10-Jun-2021
	8-5	10-Jun-2021
	8-6	10-Jun-2021
	8-7	10-Jun-2021
	8-8	10-Jun-2021
	8-9	10-Jun-2021
	8-10	10-Jun-2021
	8-11	10-Jun-2021
	8-12	10-Jun-2021
	8-13	10-Jun-2021
	8-14	10-Jun-2021
	8-15	10-Jun-2021
	8-16	10-Jun-2021

Ch.	Page	Date
9	9-1	10-Jun-2021
	9-2	10-Jun-2021
	9-3	10-Jun-2021
	9-4	10-Jun-2021
	9-5	10-Jun-2021
	9-6	10-Jun-2021

0.4 TABLE OF CONTENTS

	Chapter
GENERAL (a non-approved chapter)	1
OPERATING LIMITATIONS (an approved chapter)	2
EMERGENCY PROCEDURES (a non-approved chapter)	3
NORMAL OPERATING PROCEDURES (a non-approved chapter)	4A
ABNORMAL OPERATING PROCEDURES (a non-approved chapter)	4B
PERFORMANCE (a non-approved chapter)	5
MASS AND BALANCE / EQUIPMENT LIST (a non-approved chapter)	6
DESCRIPTION OF THE AIRPLANE AND ITS SYSTEMS (a non-approved chapter)	7
AIRPLANE HANDLING, CARE AND MAINTENANCE (a non-approved chapter)	8
SUPPLEMENTS	9

CHAPTER 1

GENERAL

	Page
1.1 INTRODUCTION	1-2
1.2 CERTIFICATION BASIS	1-5
1.3 WARNINGS, CAUTIONS AND NOTES	1-5
1.4 DIMENSIONS	1-6
1.5 DEFINITIONS AND ABBREVIATIONS	1-8
1.6 UNITS OF MEASUREMENT	1-17
1.6.1 CONVERSION FACTORS	1-17
1.6.2 CONVERSION CHART LITERS / US GALLONS	1-19
1.7 THREE-VIEW DRAWING	1-20
1.8 G1000 AVIONICS SYSTEM	1-21
1.9 SOURCE DOCUMENTATION	1-24
1.9.1 ENGINE	1-24
1.9.2 PROPELLER	1-24
1.9.3 AVIONICS SYSTEM	1-25

1.1 INTRODUCTION

This Airplane Flight Manual has been prepared in order to provide pilots and instructors with all the information required for the safe and efficient operation of the airplane.

The Airplane Flight Manual includes all the data which must be made available to the pilot according to the JAR-23 requirement. Beyond this, it contains further data and operating instructions which, in the manufacturer's opinion, could be of value to the pilot.

Equipment and modification level (design details) of the airplane may vary from serial number to serial number. Therefore, some of the information contained in this manual is applicable depending on the respective equipment and modification level. The exact equipment of your serial number is recorded in the Equipment Inventory in Section 6.5. The modification level is recorded in the following table (as far as necessary for this manual).

Modification	Source	Installed	
		<input type="checkbox"/> yes	<input type="checkbox"/> no
Maximum Landing Mass 1999 kg	MÄM 42-659	<input type="checkbox"/> yes	<input type="checkbox"/> no
Maximum Take-Off Weight 1999 kg and Maximum Zero Fuel Mass 1835 kg	MÄM 42-678	<input type="checkbox"/> yes	<input type="checkbox"/> no
Engine Software VC33_2_05_19*	MÄM 42-938	<input type="checkbox"/> yes	<input type="checkbox"/> no
Garmin Hard- and Software Upgrade I (Garmin G1000 NXi)	MÄM 42-978	<input type="checkbox"/> yes	<input type="checkbox"/> no
Garmin Hard- and Software Upgrade II (Garmin G1000 NXi)	MÄM 42-1072	<input type="checkbox"/> yes	<input type="checkbox"/> no
Ice Protection System	OÄM 42-053	<input type="checkbox"/> yes	<input type="checkbox"/> no
Oxygen System	OÄM 42-055	<input type="checkbox"/> yes	<input type="checkbox"/> no
Auxiliary Fuel Tanks	OÄM 42-056	<input type="checkbox"/> yes	<input type="checkbox"/> no
Front Seats with Adjustable Backrest	OÄM 42-067	<input type="checkbox"/> yes	<input type="checkbox"/> no

Modification	Source	Installed	
		<input type="checkbox"/> yes	<input type="checkbox"/> no
Electrical Rudder Pedal Adjustment	OÄM 42-070	<input type="checkbox"/> yes	<input type="checkbox"/> no
Sun Visors	OÄM 42-101 OR OÄM 42-142	<input type="checkbox"/> yes	<input type="checkbox"/> no
Garmin GWX 68 Weather Radar	OÄM 42-119	<input type="checkbox"/> yes	<input type="checkbox"/> no
Ice Protection System	OÄM 42-160	<input type="checkbox"/> yes	<input type="checkbox"/> no
Ice Protection System with TKS Tank in Rear Fuselage	OÄM 42-160 AND OÄM 42-203	<input type="checkbox"/> yes	<input type="checkbox"/> no
Garmin G1000, SBAS Operation	OÄM 42-179	<input type="checkbox"/> yes	<input type="checkbox"/> no
Removal of Variable Elevator Stop	OÄM 42-199	<input type="checkbox"/> yes	<input type="checkbox"/> no
Emergency Axe	OÄM 42-205	<input type="checkbox"/> yes	<input type="checkbox"/> no
Short Baggage Extension	OÄM 42-207	<input type="checkbox"/> yes	<input type="checkbox"/> no
Electronic Stability and Protection (ESP)	OÄM 42-209	<input type="checkbox"/> yes	<input type="checkbox"/> no
Mission Alternator	OÄM 42-218	<input type="checkbox"/> yes	<input type="checkbox"/> no
Removal of Unfeathering Accumulator	OÄM 42-224	<input type="checkbox"/> yes	<input type="checkbox"/> no
Diesel Operation	OÄM 42-251	<input type="checkbox"/> yes	<input type="checkbox"/> no
Garmin GTX 3X5R Transponders for ADS-B	OÄM 42-258	<input type="checkbox"/> yes	<input type="checkbox"/> no
Front Seats with Adjustable Backrest - Hydrolok	OÄM 42-259	<input type="checkbox"/> yes	<input type="checkbox"/> no
Maximum Take-Off Weight 2001 kg / 4411 lb	OÄM 42-260	<input type="checkbox"/> yes	<input type="checkbox"/> no
Mid Continent MD302 Standby Attitude Module	OÄM 42-270	<input type="checkbox"/> yes	<input type="checkbox"/> no

Modification	Source	Installed	
Garmin GWX 70 Weather Radar	OÄM 42-273	<input type="checkbox"/> yes	<input type="checkbox"/> no
Gear Warning Mute Function	OÄM 42-288	<input type="checkbox"/> yes	<input type="checkbox"/> no
Emergency Egress Hammer	OÄM 42-304	<input type="checkbox"/> yes	<input type="checkbox"/> no

* Or later approved software

This Airplane Flight Manual must be kept on board the airplane at all times. Its designated place is the side bag of the forward left seat. The designated place for the Garmin G1000 Cockpit Reference Guide is the bag on the rear side of the forward left seat.

This Airplane Flight Manual is applicable for DA 42 NG airplanes with design change MÄM 42-600 installed.

CAUTION

The DA 42 NG is a twin engine airplane. When the operating limitations and maintenance requirements are complied with, it has the high degree of reliability which is required by the certification basis. Nevertheless, an engine failure is not completely impossible. For this reason it is highly recommended for flights during the night, on top, under IMC, or above terrain which is unsuitable for a landing, to select flight times and flight routes such that reduced performance in case of single engine operation does not constitute a risk.

1.2 CERTIFICATION BASIS

The certification basis is JAR-23, published on 11-Mar-1994, including Amdt. 1, and additional requirements as laid down in CRI A-01.

1.3 WARNINGS, CAUTIONS AND NOTES

Special statements in the Airplane Flight Manual concerning the safety or operation of the airplane are highlighted by being prefixed by one of the following terms:

WARNING

means that the non-observation of the corresponding procedure leads to an immediate or important degradation in flight safety.

CAUTION

means that the non-observation of the corresponding procedure leads to a minor or to a more or less long term degradation in flight safety.

NOTE

draws the attention to any special item not directly related to safety but which is important or unusual.

1.4 DIMENSIONS

NOTE

All dimensions shown below are approximate.

Overall Dimensions

Span	: 13.42 m	44 ft
	: 13.55 m	44.5 ft including ACL
Length	: 8.56 m	28 ft 1 in
Height	: 2.49 m	8 ft 2 in

Wing

Airfoil	: Wortmann FX 63-137/20 - W4	
Wing Area	: 16.29 m ²	175.3 sq.ft.
Mean aerodynamic chord	: 1.271 m	4 ft 2 in
Aspect ratio	: 11.06	
Dihedral	: 5°	
Leading edge sweep	: 1°	

Aileron

Area (total, left + right)	: 0.66 m ²	7.1 sq.ft.
----------------------------	-----------------------	------------

Wing Flaps

Area (total, left + right) : 2.18 m² 23.5 sq.ft.

Horizontal Tail

Area : 2.35 m² 25.3 sq.ft.

Elevator area : 0.66 m² 7.1 sq.ft.

Angle of incidence : -1.1° relative to longitudinal axis of airplane

Vertical Tail

Area : 2.43 m² 26.2 sq.ft.

Rudder area : 0.78 m² 8.4 sq.ft.

Landing Gear

Track : 2.95 m (9 ft 8 in)

Wheelbase : 1.735 m (5 ft 8 in)

Nose wheel : 5.00-5, for details refer to the AMM

Main wheel : 15x6.0-6, for details refer to the AMM

1.5 DEFINITIONS AND ABBREVIATIONS

(a) Airspeeds

CAS: Calibrated Airspeed. Indicated airspeed, corrected for installation and instrument errors. CAS equals TAS at standard atmospheric conditions (ISA) at MSL.

IAS: Indicated Airspeed as shown on an airspeed indicator.

KCAS: CAS in knots.

KIAS: IAS in knots.

TAS: True Airspeed. The speed of the airplane relative to the air. TAS is CAS corrected for errors due to altitude and temperature.

V_O : Operating Maneuvering Speed. Full or abrupt control surface movement is not permissible above this speed.

V_{FE} : Maximum Flaps Extended Speed. This speed must not be exceeded with the given flap setting.

V_{LE} : Maximum Landing Gear Extended Speed. This speed may not be exceeded if the landing gear is extended.

V_{LOE} : Maximum Landing Gear Operating Speed for Extension. This speed may not be exceeded during the extension of the landing gear.

V_{LOR} : Maximum Landing Gear Operating Speed for Retraction. This speed may not be exceeded during the retraction of the landing gear.

V_{MCA} : Minimum Control Speed - Airborne. Minimum speed necessary to be able to control the airplane in case of one engine inoperative.

V_{NE} : Never Exceed Speed in smooth air. This speed must not be exceeded in any operation.

- V_{NO} : Maximum Structural Cruising Speed. This speed may be exceeded only in smooth air, and then only with caution.
- V_S : Stalling Speed, or the minimum continuous speed at which the airplane is still controllable in the given configuration.
- V_{S0} : Stalling Speed, or the minimum continuous speed at which the airplane is still controllable in the landing configuration.
- V_{S1} : Stalling Speed, or the minimum continuous speed at which the airplane is still controllable with flaps and landing gear retracted.
- V_{SSE} : Minimum Control Speed for Schooling. Minimum speed necessary in case of one engine intentionally inoperative / idle (training purposes).
- V_x : Best Angle-of-Climb Speed.
- V_y : Best Rate-of-Climb Speed.
- V_{YSE} : Best Rate of-Climb Speed for one engine inoperative.

(b) Meteorological Terms

- ISA: International Standard Atmosphere. Conditions at which air is identified as an ideal dry gas. The temperature at mean sea level is 15 °C (59 °F), air pressure at MSL is 1013.25 hPa (29.92 inHg); the temperature gradient up to the altitude at which the temperature reaches -56.5 °C (-69.7 °F) is -0.0065 °C/m (-0.00357 °F/ft), and above this 0 °C/m (0 °F/ft).
- MSL: Mean Sea Level.
- OAT: Outside Air Temperature.

QNH: Theoretical atmospheric pressure at MSL, calculated from the elevation of the measuring point above MSL and the actual atmospheric pressure at the measuring point.

Density Altitude:

Altitude in ISA conditions at which the air density is equal to the current air density.

Indicated Pressure Altitude:

Altitude reading with altimeter set to 1013.25 hPa (29.92 inHg).

Pressure Altitude:

Altitude indicated by a barometric altimeter, which is set to 1013.25 hPa (29.92 inHg). The Pressure Altitude is the Indicated Pressure Altitude corrected for installation and instrument errors.

In this Airplane Flight Manual altimeter instrument errors are regarded as zero.

Wind:

The wind speeds which are shown as variables in the diagrams and tables in this manual should be regarded as headwind or tailwind components of the measured wind.

(c) Flight Performance and Flight Planning

AGL: Above Ground Level.

Demonstrated Crosswind Component:

The speed of the crosswind component at which adequate maneuverability for take-off and landing has been demonstrated during type certification.

MET: Weather, weather advice.

NAV: Navigation, route planning.

RoC: Rate of Climb.

(d) Mass and Balance

CG: Center of Gravity, also called 'center of mass'. Imaginary point in which the airplane mass is assumed to be concentrated for mass and balance calculations. Its distance from the Datum Plane is equal to the Center of Gravity Moment Arm.

Center of Gravity Moment Arm:

The Moment Arm which is obtained if one divides the sum of the individual moments of the airplane by its total mass.

Center of Gravity Limits:

The Center of Gravity range within which the airplane, at a given mass, must be operated.

DP: Datum Plane; an imaginary vertical plane from which all horizontal distances for center of gravity calculations are measured.

Empty Mass: The mass of the airplane including unusable fuel, all operating fluids and the maximum quantity of oil.

Maximum Take-off Mass:

The maximum permissible mass for take-off.

Maximum Landing Mass:

The highest mass for landing conditions at the maximum descent velocity. This velocity was used in the strength calculations to determine the landing gear loads during a particularly hard landing.

Moment Arm: The horizontal distance from the Datum Plane to the Center of Gravity of a component.

Moment: The mass of a component multiplied by its moment arm.

Usable fuel: The quantity of fuel available for flight planning.

Unusable fuel: The quantity of fuel remaining in the tank which cannot be used for flight.

Useful load: The difference between take-off mass and empty mass.

(e) Engine

EECU: Electr. Engine Control Unit

RPM: Revolutions per minute (rotational speed of the propeller)

Engine starting fuel temperature:

Above this fuel temperature the engine may be started.

Take-off fuel temperature:

Above this fuel temperature take-off power setting is permitted.

OEI: One engine inoperative

(f) Designation of the Circuit Breakers on the Instrument Panel*LH MAIN BUS:*

COM1	COM Radio No. 1
GPS/NAV1	Global Positioning System and NAV Receiver No. 1
XPDR	Transponder
ENG INST	Engine Instruments
PITOT	Pitot Heating System
XFER PUMP/DE-ICE	Aux Fuel Pump / De-Icing System
TAXI/MAP/ACL	Taxi-, Map-, Anti Collision Light
FLOOD	Flood Light
PFD	Primary Flight Display
ADC	Air Data Computer
AHRS	Attitude Heading Reference System
GEAR WRN/ELEV. LIMIT	Landing Gear Annunciation / Variable Elevator Stop
GEAR	Landing Gear Control

RH MAIN BUS:

MFD	Multi Function Display
AH	Artificial Horizon / Standby Attitude Module
STALL WRN	Stall Warning System
FLAP	Flap System
LDG LT/START	Landing Light / Start
INST LT/ NAV LT	Instrument-, Navigation (Position) Light
AV/CDU/FAN	Avionic-, CDU-Cooling Fans
AVIONIC BUS	Avionic Bus
AV CONT./AP. WRN.	Avionic Control / Autopilot Warning (not used)

AVIONICS BUS:

COM2	COM Radio No. 2
GPS/NAV2	Global Positioning System and NAV Receiver No. 2
AUDIO	Audio Panel
AUTO PILOT	Auto Pilot System
Wx 500	Stormscope
ADF	Automatic Direction Finder
DME	Distance Measuring Equipment
Wx RDR	Weather Radar
TAS	Traffic Advisory System
DATA LINK	GDL 69A Data Link System
IRIDIUM	GSR 56 Satellite Receiver

LH ENG ECU BUS:

ECU BUS	LH ECU Bus
ECU B	LH ECU B
ECU A	LH ECU A

LH BUS:

ALT.LH	LH Alternator
BATT	Battery

FUEL PUMPS LH ENGINE:

FUEL PUMP A	LH ECU A Fuel Pump
FUEL PUMP B	LH ECU B Fuel Pump

RH ENG ECU BUS:

ECU BUS	RH ECU Bus
ECU B	RH ECU B
ECU A	RH ECU A

RH BUS:

ALT.RH	RH Alternator
BATT	Battery

FUEL PUMPS RH ENGINE:

FUEL PUMP A	RH ECU A Fuel Pump
FUEL PUMP B	RH ECU B Fuel Pump

(g) Equipment

ELT: Emergency Locator Transmitter

(h) Design Change Advisories

MÄM: Mandatory Design Change Advisory
OÄM: Optional Design Change Advisory
VÄM: Variant Design Change Advisory

(i) Miscellaneous

ACG:	Austro Control GmbH (Austrian Airworthiness Authority)
ATC:	Air Traffic Control
CFRP:	Carbon Fiber Reinforced Plastic
EASA:	European Aviation Safety Agency
EFB:	Electronic Flight Bag
EPU:	External Power Unit
GIA:	Garmin Integrated Avionics
GFRP:	Glass Fiber Reinforced Plastic
GPS:	Global Positioning System
IFR:	Instrument Flight Rules
IPL:	Interference Path Loss
JAR:	Joint Aviation Requirements
JC/VP:	Joint Certification/Validation Procedure
PCA:	Primary Certification Authority
PED:	Portable Electronic Device
PPM	Parts per Million (Dosage)
T-PED:	Transmitting Portable Electronic Device
VFR:	Visual Flight Rules

1.6 UNITS OF MEASUREMENT

1.6.1 CONVERSION FACTORS

Dimension	SI-Units	US Units	Conversion
Length	[mm] millimeters	[in] inches	$[mm] / 25.4 = [in]$
	[m] meters	[ft] feet	$[m] / 0.3048 = [ft]$
	[km] kilometers	[NM] nautical miles	$[km] / 1.852 = [NM]$
Volume	[l] liters	[US gal] US gallons	$[l] / 3.7854 = [US gal]$
		[qts] US quarts	$[l] / 0.9464 = [qts]$
	[ml] milliliter	[oz] ounce	$[ml] \times 0.033814 = [oz]$
Speed	[km/h] kilometers per hour	[kts] knots	$[km/h] / 1.852 = [kts]$
		[mph] miles per hour	$[km/h] / 1.609 = [mph]$
	[m/s] meters per second	[fpm] feet per minute	$[m/s] \times 196.85 = [fpm]$
			$[fpm] / 196.85 = [m/s]$
Speed of rotation	[RPM] revolutions per minute		--
Mass	[kg] kilograms	[lb] pounds	$[kg] \times 2.2046 = [lb]$
Force, weight	[N] newtons	[lbf] pounds force	$[N] \times 0.2248 = [lbf]$
Pressure	[hPa] hecto-pascals	[inHg] inches of mercury	$[hPa] = [mbar]$
	[mbar] millibars	[psi] pounds per square inch	$[hPa] / 33.86 = [inHg]$
	[bar] bars		$[bar] \times 14.504 = [psi]$
Temperature	[°C] degrees Celsius	[°F] degrees Fahrenheit	$[°C] \times 1.8 + 32 = [°F]$ $([°F] - 32) / 1.8 = [°C]$

Dimension	SI-Units	US Units	Conversion
Intensity of electric current	[A] ampères		--
Electric charge (battery capacity)	[Ah] ampère-hours		--
Electric potential	[V] volts		--
Time	[sec] seconds		--

1.6.2 CONVERSION CHART LITERS / US GALLONS

Liters	US Gallons
5	1.3
10	2.6
15	4.0
20	5.3
25	6.6
30	7.9
35	9.2
40	10.6
45	11.9
50	13.2
60	15.9
70	18.5
80	21.1
90	23.8
100	26.4
110	29.1
120	31.7
130	34.3
140	37.0
150	39.6
160	42.3
170	44.9
180	47.6

US Gallons	Liters
1	3.8
2	7.6
4	15.1
6	22.7
8	30.3
10	37.9
12	45.4
14	53.0
16	60.6
18	68.1
20	75.7
22	83.3
24	90.9
26	98.4
28	106.0
30	113.6
32	121.1
34	128.7
36	136.3
38	143.8
40	151.4
45	170.3
50	189.3

1.7 THREE-VIEW DRAWING

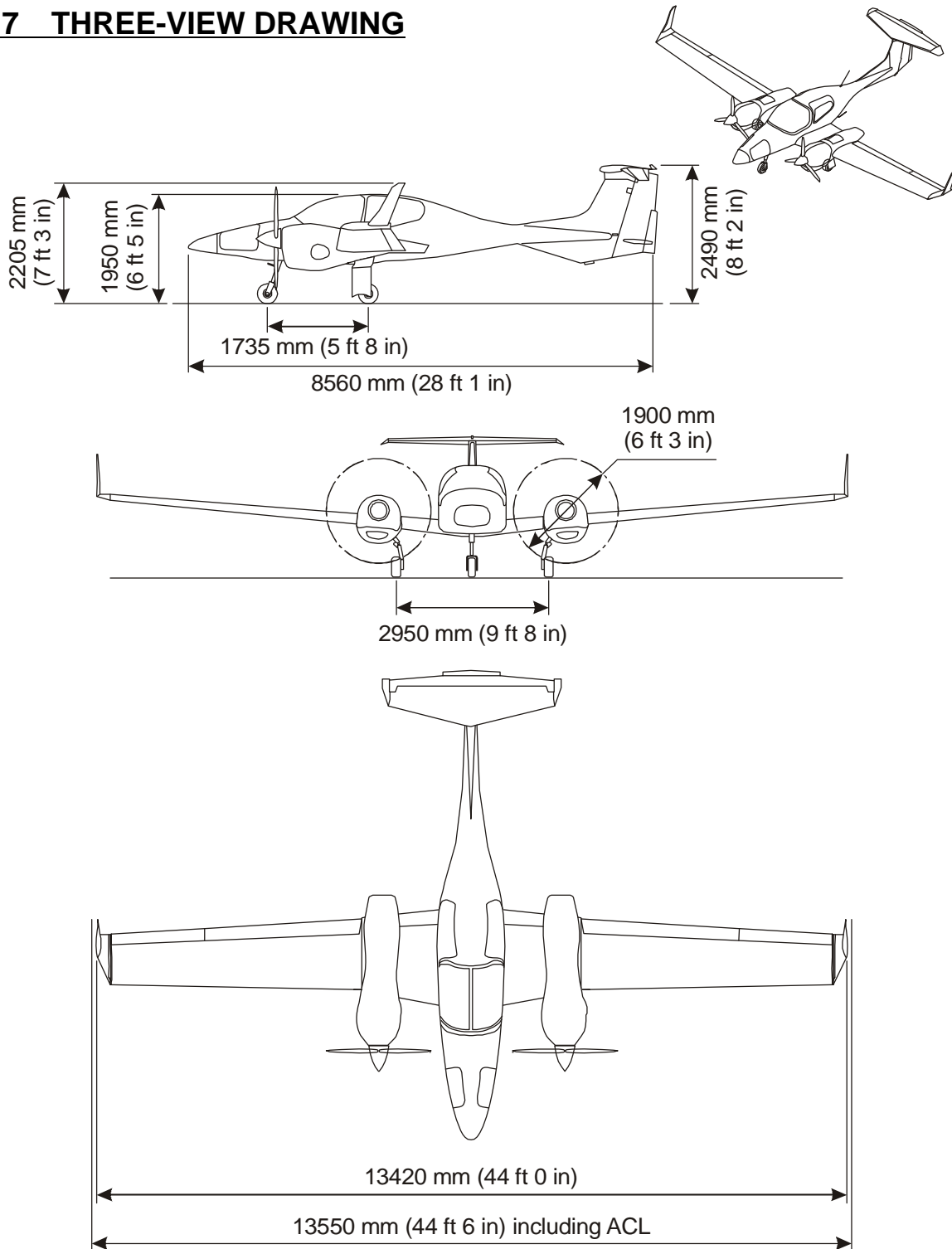

1.8 G1000 AVIONICS SYSTEM

1. The G1000 Integrated Avionics System is a fully integrated flight, engine, communication, navigation and surveillance instrumentation system. The system consists of a Primary Flight Display (PFD), Multi-Function Display (MFD), audio panel, Air Data Computer (ADC), Attitude and Heading Reference System (AHRS), engine sensors and processing unit (GEA), and integrated avionics (GIA) containing VHF communications, VHF navigation, and GPS (Global Positioning System).
2. The primary function of the PFD is to provide attitude, heading, air data, navigation, and alerting information to the pilot. The PFD may also be used for flight planning. The primary function of the MFD is to provide engine information, mapping, terrain information, autopilot operation, and for flight planning. The audio panel is used for selection of radios for transmitting and listening, intercom functions, and marker beacon functions.
3. The primary function of the VHF Communication portion of the G1000 is to enable external radio communication. The primary function of the VOR/ILS Receiver portion of the equipment is to receive and demodulate VOR, Localizer, and Glide Slope signals. The primary function of the GPS portion of the system is to acquire signals from the GPS satellites, recover orbital data, make range and Doppler measurements, and process this information in real-time to obtain the user's position, velocity, and time.

4. If the Garmin GWX 68 or the GWX 70 weather radar system is installed, it can be used to aid the pilot in avoiding thunderstorms and associated turbulence or for ground mapping. The GWX 68 and the GWX 70 shall be used to avoid severe weather and not for penetrating severe weather. Pulse type weather radar systems like the GWX 68 and the GWX 70 detect precipitation only, not clouds or turbulence. The display may indicate clear areas between intense returns, but this does not necessarily mean it is safe to fly between them. As installed on the DA 42 NG, the Garmin GWX 68 and the GWX 70 has a demonstrated range of 160 nautical miles. Refer to Garmin G1000 Pilot's Guide for the DA 42 NG, P/N 190-00962-() for Garmin G1000 or P/N 190-02237-() for G1000 NXi (MÄM 42-978) or P/N 190-02526-() for G1000 NXi (MÄM 42-1072) in the latest effective issue for further information.
5. If OÄM 42-257 (Garmin GTX 33 ES transponder) and MÄM 42-828 (G1000 Software P/N 010-00670-12) are implemented, the installed ADS-B Out system is compliant to TSO-C166b / RTCA DO-206B. This constitutes no airworthiness approval.
- If OÄM 42-257 (Garmin GTX 33ES transponder) and MÄM 42-1000 (G1000 Software P/N 010-00670-15) are implemented, the following functions are performed:
- Transmission of ADS-B out data on 1090 extended squitter (1090 MHz)
 - Integration of data from internal and external sources to transmit the following data per 14 CFR 91.227:
 - GPS Position, Altitude, and Position Integrity
 - Ground Track and/or Heading, Ground Speed, and Velocity Integrity
 - Air Ground Status
 - Flight ID, Call Sign, ICAO Registration Number
 - Capability and Status Information
 - Transponder Squawk Codes between 0000-7777
 - Emergency Status
 - IDENT - initiates SPI (special position identification) pulse for 18 seconds

The Garmin GTX 33ES transponders for ADS-B meet the requirements in EASA AMC 20-24 for ADS-B (Automatic Dependent Surveillance-Broadcast) and ELS.

6. If a Garmin GTX 3X5R transponder for ADS-B (GTX 335R, GTX 345R) is installed the following functions are performed:

- Transmission of ADS-B out data on 1090 extended squitter (1090 MHz)
- Integration of data from internal and external sources to transmit the following data per 14 CFR 91.227:
 - GPS Position, Altitude, and Position Integrity
 - Ground Track and/or Heading, Ground Speed, and Velocity Integrity
 - Air Ground Status
 - Flight ID, Call Sign, ICAO Registration Number
 - Capability and Status Information
 - Transponder Squawk Codes between 0000-7777
 - Emergency Status
 - IDENT - initiates SPI (special position identification) pulse for 18 seconds

The Garmin GTX 3X5R transponders for ADS-B meet the requirements in EASA AMC 20-24 for ADS-B (Automatic Dependent Surveillance-Broadcast) and ELS.

7. Refer to Garmin G1000 Pilot's Guide for the DA 42 NG, P/N 190-00962-() for Garmin G1000 or P/N 190-02237-() for G1000 NXi (MÄM 42-978) or P/N 190-02526-() for G1000 NXi (MÄM 42-1072) in the latest effective issue for further information.

8. The airplane has been assessed for back door coupling susceptibility in accordance with EUROCAE ED-239 Section 3 and found PED tolerant for back door coupling. The airplane has been assessed for front door coupling susceptibility in accordance with EUROCAE ED-130A Appendix A. No IPL determination was made.

1.9 SOURCE DOCUMENTATION

This section lists documents, manuals and other literature that were used as sources for the Airplane Flight Manual, and indicates the respective publisher. However, only the information given in the Airplane Flight Manual is valid.

1.9.1 ENGINE

Address: Austro Engine GmbH
Rudolf Diesel-Str. 11
A-2700 Wiener Neustadt
AUSTRIA

Phone: +43-2622-23 000
Fax: +43-2622-23 000 - 2711
Internet: www.austroengine.at

Documents: Operation Manual,
E4.01.01, latest revision

1.9.2 PROPELLER

Address: mt-propeller
Airport Straubing Wallmühle
D-94348 Atting
GERMANY

Phone: +49-9429-9409-0
E-mail: sales@mt-propeller.com
Website: www.mt-propeller.de

Documents: E-124, Operation and Installation Manual
Hydraulically controlled variable pitch propeller
MTV -5, -6, -9, -11, -12, -14, -15, -16, -21, -22, -25

1.9.3 AVIONICS SYSTEM

Address: Garmin International, Inc.
 1200 East 151st Street
 Olathe, Kansas 66062
 USA

Phone: +1-(913)-3978200

Fax: +1-(913)-3978282

Website: www.garmin.com

Documents: G1000 Cockpit Reference Guide
 P/N 190-00963-(), latest revision

 G1000 Pilot's Guide
 P/N 190-00962-(), latest revision

■ If MÄM 42-978 is installed:

 G1000 NXi Cockpit Reference Guide
 P/N 190-02238-(), latest revision

 G1000 NXi Pilot's Guide
 P/N 190-02237-(), latest revision

■ If MÄM 42-1072 is installed:

■ G1000 NXi Cockpit Reference Guide
■ P/N 190-02527-(), latest revision

■ G1000 NXi Pilot's Guide
■ P/N 190-02526-(), latest revision

Intentionally left blank.

CHAPTER 2

OPERATING LIMITATIONS

	Page
2.1 INTRODUCTION	2-3
2.2 AIRSPEED	2-4
2.3 AIRSPEED INDICATOR MARKINGS	2-5
2.4 POWER-PLANT LIMITATIONS	2-6
2.5 ENGINE INSTRUMENT MARKINGS	2-12
2.6 WARNING, CAUTION AND ADVISORY ALERTS	2-14
2.6.1 WARNING, CAUTION AND ADVISORY ALERTS ON THE G1000	2-14
2.6.2 OTHER WARNING ALERTS	2-18
2.7 MASS (WEIGHT)	2-19
2.8 CENTER OF GRAVITY	2-21
2.9 APPROVED MANEUVERS	2-23
2.10 MANEUVERING LOAD FACTORS	2-24
2.11 OPERATING ALTITUDE	2-25
2.12 FLIGHT CREW	2-25
2.13 KINDS OF OPERATION	2-25
2.14 FUEL	2-29
2.15 LIMITATION PLACARDS	2-32
2.16 OTHER LIMITATIONS	2-38
2.16.1 FUEL TEMPERATURE	2-38
2.16.2 BATTERY CHARGE	2-38
2.16.3 EMERGENCY SWITCH	2-38
2.16.4 DOOR LOCKING DEVICE	2-38
2.16.5 PORTABLE ELECTRONIC DEVICES	2-39

2.16.6 GARMIN G1000 AVIONICS SYSTEM 2-40

2.16.7 AUTOPILOT LIMITATIONS 2-45

2.16.8 SMOKING 2-47

2.16.9 GROUND OPERATION 2-47

2.16.10 USE OF THE SUN VISORS 2-47

2.16.11 GARMIN GWX 68 / GWX 70 WEATHER RADAR OPERATION
..... 2-47

2.16.12 MID CONTINENT MD302 STANDBY ATTITUDE MODULE
..... 2-47

2.1 INTRODUCTION

Chapter 2 of this Airplane Flight Manual provides operating limitations, instrument markings and placards necessary for the safe operation of the airplane, its powerplants, standard systems and standard equipment.

The limitations included in this Chapter are approved.

WARNING

Operation of the airplane outside of the approved operating limitations is not permissible.

NOTE

Exceeding the operating limitations related to physical properties of the airplane (e.g. speeds, load factors, weights...) requires unscheduled maintenance prior to further operation.

2.2 AIRSPEED

	Airspeed		CIAS	Remarks
V _O	Operating maneuvering speed	above 1800 kg (3968 lb)	122 KIAS	Do not make full or abrupt control surface movement above this speed.
		above 1700 kg (3748 lb) to 1800 kg (3968 lb)	119 KIAS	
		up to 1700 kg (3748 lb)	112 KIAS	
V _{FE}	Max. flaps extended speed	LDG	113 KIAS	Do not exceed these speeds with the given flap setting.
		APP	133 KIAS	
V _{LO}	Max. landing gear operating speed	Extension v _{LOE}	188 KIAS	Do not operate the landing gear above this speed.
		Retraction v _{LOR}	152 KIAS	
V _{LE}	Max. landing gear extended speed		188 KIAS	Do not exceed this speed with the landing gear extended.
V _{MCA}	Minimum control speed airborne	APP	68 KIAS	With one engine inoperative, keep airspeed above this limit.
		UP	71 KIAS	
V _{NO}	Max. structural cruising speed		151 KIAS	Do not exceed this speed except in smooth air, and then only with caution.
V _{NE}	Never exceed speed in smooth air		188 KIAS	Do not exceed this speed in any operation.

2.3 AIRSPEED INDICATOR MARKINGS

Marking	KIAS	Significance
White arc	62 - 113 KIAS If MÄM 42-678 is carried out: 64 - 113 KIAS	Operating range with flaps fully extended.
Green arc	68 - 151 KIAS If MÄM 42-678 is carried out: 72 - 151 KIAS	Normal operating range.
Yellow arc	151 - 188 KIAS	'Caution' range - "Only in smooth air".
Blue radial	85 KIAS	Best rate of climb speed, single engine.
Red radial	71 KIAS	Minimum control speed, single engine.
Red radial	188 KIAS	Maximum speed for all operations - V_{NE} .

2.4 POWER-PLANT LIMITATIONS

- a) Number of engines : 2
- b) Engine manufacturer : Austro Engine
- c) Engine designation : E4-C
- d) RPM limitations (shown as propeller RPM)
- Maximum take-off (rpm) : 2300 RPM
 - Maximum continuous (rpm) : 2300 RPM
 - Maximum overspeed : 2500 RPM max. 20 sec
- e) Engine power
- Max. take-off power : 100% (123.5 kW) max. 5 min
 - Max. continuous power : 92% (114 kW)
- f) Oil pressure (absolute)
- Minimum < 1500 RPM : 0.9 bar
 - Minimum \geq 1500 RPM : 2.5 bar
 - Maximum : 6.5 bar
 - Normal range : 2.5 bar - 6 bar
- g) Oil quantity
- Minimum : 5.0 l
 - Maximum : 7.0 l
 - Maximum oil consumption : 0.1 liter/hr

h) Oil temperature

Minimum	:	- 30 °C
Maximum	:	140 °C
Normal range	:	50 °C - 135 °C

i) Gearbox temperature

Minimum	:	- 30 °C
Minimum (full load)	:	35 °C
Maximum	:	120 °C

NOTE

A cautionary (yellow) gearbox temperature range is not imposed by the engine manufacturer. However, there is a delay between power changes and gearbox temperature. Therefore, a cautionary range has been added to the G1000 gearbox temperature instrument solely to make the pilot attentive to the gearbox temperature approaching the maximum allowable limit. There is no specific time limit associated with operating in the cautionary gearbox temperature range.

j) Coolant temperature

Minimum (at start-up)	:	- 30 °C
Minimum (full load)	:	60 °C
Maximum	:	105 °C

k) Fuel temperature

Minimum : - 30 °C

Maximum : 60 °C

l) Fuel pressure

Minimum : 4 bar

Maximum : 7 bar

NOTE

The fuel pressure is not indicated on the G1000; a fuel pressure warning will illuminate on the PFD if the pressure is below limit.

m) Voltage

Minimum : 24.1 V

Maximum : 32.0 V

n) Amperage

Maximum : 70 A

o) Propeller manufacturer : mt-Propeller

p) Propeller designation : MTV-6-R-C-F / CF 190-69

q) Propeller diameter : 190 cm

r) Prop. pitch angle (@ 0.75 R) : 13° ± 0.2° (low pitch)

80° ± 1° (feathered position)

s) Governor : mt-Propeller P-877-16 electrical governor with feather position

- t) Oil specification
- : SAE Grade 5W-30:
 SHELL HELIX ULTRA
 ADDINOL SUPER POWER MV 0537
 BP VISCO 5000
 REPSOL ELITE COMMON RAIL
 GULF FORMULA GMX
 AEROSHELL Oil Diesel Ultra
 CASTROL Edge 5W-30 A3
 CASTROL Edge Professional A3
 G-Energy F Synth
 TOTAL Quartz 9000 Energy
- SAE Grade 5W-40:
 SHELL HELIX ULTRA
 LIQUI MOLY LEICHTLAUF HIGH TECH
 MEGOL MOTORENOEL HIGH CONDITION
 PETRONAS Syntium 3000
 LUKOIL LUXE SYNTHETIC
 CASTROL Edge Professional A3
 CASTROL Magnatec Professional A3
 VALVOLINE SynPower HST
 VALVOLINE SynPower
 GULF Formula GX
 AUSTRO ENGINE Aero
 produced by Liqui Moly
 recommended by Austro Engine GmbH
- SAE Grade 0W-40:
 CASTROL SLX PROFESSIONAL LONGTEC
 CASTROL Edge 0W-40 A3/B4
 CASTROL Edge Professional A3
 SHELL Helix Ultra

CAUTION

Only engine oils conforming to MB 229.5 specification are approved by Austro Engine GmbH to be used for operation. Use only one type of approved E4 engine oil for an oil change.

NOTE

It is not recommended to mix different SAE grades.

- u) Gearbox oil (propeller gearbox) : SHELL SPIRAX GSX 75W-80
SHELL SPIRAX S6 GXME 75W-80
- v) Coolant : Distilled water / cooler protection (BASF Glysantin Protect Plus / G48) 1/1. The freezing point of the coolant is - 38°C.

CAUTION

If the coolant or gearbox oil level is low the reason must be determined and the problem must be corrected by authorized personnel.

2.5 ENGINE INSTRUMENT MARKINGS

Engine instrument markings and their color code significance are shown in the tables below.

Indi- cation	Red arc/bar = lower prohibited range	Yellow arc/bar = caution range	Green arc/bar = normal operating range	Yellow arc/bar = caution range	Red arc/bar = upper prohibited range
RPM	--	--	up to 2300 RPM	--	above 2300 RPM
Oil pressure	below 0.9 bar	0.9 to 2.5 bar	2.5 to 6.0 bar	6.0 to 6.5 bar	above 6.5 bar
Oil temp.	below -30°C	-30° to 50°C	50° to 135°C	135° to 140°C	above 140°C
Coolant temp.	below -30°C	-30° to 60°C	60° to 95°C	95° to 105°C	above 105°C
Gearbox temp.	below -30°C	-30° to 35°C	35° to 115°C	115° to 120°C	above 120°C
Load	--	--	up to 92%	92 - 100%	--
Fuel temp. ^{*1)}	below -30°C	-30° to -20°C	-20° to 55°C	55° to 60°C	above 60°C
Fuel temp. ^{*2)}	below -30°C	-	-30° to 55°C	55° to 60°C	above 60°C
Ammeter	--	--	up to 60A	60 to 70A	above 70A
Volt- meter	below 24.1V	24.1 to 25V	25 to 30V	30 to 32V	above 32V

Indi- cation	Red arc/bar = lower prohibited range	Yellow arc/bar = caution range	Green arc/bar = normal operating range	Yellow arc/bar = caution range	Red arc/bar = upper prohibited range
Fuel qty.	below 1 US gal	--	1 to 25 US gal	--	--

*1) If G1000 system software prior to P/N 010-00670-12 is installed.

*2) If G1000 system software P/N 010-00670-12 or later is installed.

2.6 WARNING, CAUTION AND ADVISORY ALERTS

2.6.1 WARNING, CAUTION AND ADVISORY ALERTS ON THE G1000

NOTE

The alerts described in the following are displayed on the Garmin G1000. Section 7.10 includes a detailed description of the alerts.

The following tables show the color and significance of the warning, caution and advisory alerts lights on the G1000.

Color and Significance of the Warning Alerts on the G1000

Warning alerts (red)	Meaning / Cause
WARNING	One of the warnings listed below is being indicated.
L/R ENG TEMP	Left / Right engine coolant temperature is in the upper red range (too high / >105 °C).
L/R OIL TEMP	Left / Right engine oil temperature is in the upper red range (too high / >140 °C).
L/R OIL PRES	Left / Right engine oil pressure is in the lower red range (too low / <0.9 bar).
L/R FUEL TEMP	Left / Right fuel temperature is in the upper red range (too high / >60 °C).
L/R GBOX TEMP	Left / Right engine gearbox temperature is in the upper red range (too high / >120 °C).
L/R FUEL PRESS	Left / Right engine fuel pressure is low.

Page 2 - 14	Rev. 5	10-Jun-2021	EASA approved	Doc. No. 7.01.16-E
-------------	--------	-------------	------------------	--------------------

Warning alerts (red)	Meaning / Cause
L/R ALTN AMPS	Left / Right engine alternator output is in the upper red range (too high / >70 Amps).
L/R ENG FIRE	Left / Right engine fire detected.
L/R STARTER	Left / Right engine starter is engaged.
DOOR OPEN	Front and/or rear canopy and/or baggage door are/is not closed and locked.
ATTITUDE FAIL	The display system is not receiving attitude reference information from the AHRS.
AIRSPEED FAIL	The display system is not receiving airspeed input from the air data computer.
ALTITUDE FAIL	The display system is not receiving altitude input from the air data computer.
VERT SPEED FAIL	The display system is not receiving vertical speed input from the air data computer.
HDG	The display system is not receiving valid heading input from the AHRS.
WARN	RAIM position warning. The nav deviation bar is removed.
Red X or yellow X	A red or yellow (if Garmin G1000 NXi is installed) X through any display field, such as com frequencies, nav frequencies, or engine data, indicates that the display field is not receiving valid data.

Color and Significance of the Caution Alerts on the G1000

Caution alerts (amber)	Meaning / Cause
L/R ECU A FAIL	A fault has occurred in the left/right engine ECU A (one reset of minor faults is possible) or ECU A is being tested during FADEC-test procedure during the 'Before Take-Off Check'.
L/R ECU B FAIL	A fault has occurred in the left/right engine ECU B (one reset of minor faults is possible) or ECU B is being tested during FADEC-test procedure during the 'Before Take-Off Check'.
L/R FUEL LOW	Left / Right main tank fuel quantity is low.
L/R ALTN FAIL	Left / Right engine alternator has failed.
L/R VOLTS LOW	Left / Right engine bus voltage is too low (< 25 Volts).
L/R COOL LVL	Left / Right engine coolant level is low.
PITOT FAIL	Pitot heat has failed.
PITOT HT OFF	Pitot heat is OFF.
STAL HT FAIL	Stall warning heat has failed.
STAL HT OFF	Stall warning heat is OFF.
STICK LIMIT	Control stick limiting system (variable elevator stop) has failed.
LOI	GPS integrity is insufficient for the current phase of flight.
AHRS ALIGN: Keep Wings Level	The AHRS (Attitude and Heading Reference System) is aligning.
L/R AUX FUEL E	Left / Right auxiliary fuel tank empty (if installed).

Caution alerts (amber)	Meaning / Cause
CHECK GEAR	Landing gear is not down and locked.
DEICE LVL LO	De-icing fluid level is low (if installed).
DEIC PRES HI	De-icing pressure is high (if installed).
DEIC PRES LO	De-icing pressure is low (if installed).

Color and Significance of the Advisory Alerts on the G1000

Advisory alerts (white)	Meaning / Cause
L/R GLOW ON	Left / Right engine glow plug active.
L/R AUXPUMP ON	Fuel transfer from auxiliary to main tank is in progress (if installed).
PFD FAN FAIL	Cooling fan for the PFD is inoperative.
MFD FAN FAIL	Cooling fan for the MFD is inoperative.
GIA FAN FAIL	Cooling fan for the GIAs is inoperative.

2.6.2 OTHER WARNING ALERTS

Warning Alerts on the Instrument Panel

Warning alert (red)	Meaning / Cause
GEAR UNSAFE WARNING LIGHT	Illuminates if the landing gear is neither in the final up nor in the down & locked position.

Audible Warning Alerts

Audible warning alert	Meaning / Cause
GEAR RETRACTED CHIME TONE (repeating)	Resounds if the landing gear is retracted while the flaps move into position LDG or when the power lever is placed in a position below approx. 20 %.

2.7 MASS (WEIGHT)

Value	Mass (Weight)	
	kg	lb
Minimum flight mass	1450	3197
Maximum take-off mass	1900	4189
Maximum take-off mass (if MÄM 42-678 is carried out)	1999	4407
Maximum zero fuel mass	1765	3891
Maximum zero fuel mass (if MÄM 42-659 is carried out)	1835	4045
Maximum landing mass	1805	3979
Maximum landing mass (if MÄM 42-659 is carried out)	1999	4407
Max. load in nose baggage compartment (in fuselage nose)	30	66
Max. load in cabin baggage compartment (behind rear seats)	45	100
Max. load in baggage extension (behind cabin baggage compartment)	18	40
Max. load, cabin baggage compartment and baggage extension together	45	100
if OÄM 42-207 is carried out:		
Max. load in standard baggage compartment (between rear seats and baggage bulkhead)	30	66
Max. load in short baggage extension	15	33

WARNING

Exceeding the mass limits will lead to overstressing of the airplane as well as to degradation of flight characteristics and flight performance.

NOTE

In some countries the beginning of a flight is defined by starting the powerplant. In those countries a ramp mass of maximal MTOM + 8 kg (MTOM + 18 lb) is approved. At the time of lift-off the maximum permitted take-off mass must not be exceeded.

2.8 CENTER OF GRAVITY

Datum Plane

The datum plane (DP) is a plane which is normal to the airplane's longitudinal axis and in front of the airplane as seen from the direction of flight. The airplane's longitudinal axis is parallel with the floor of the nose baggage compartment. When the floor of the nose baggage compartment is aligned horizontally, the datum plane is vertical. The datum plane is located 2.196 meters (86.46 in) forward of the most forward point of the root rib on the stub wing (refer to figure in Section 6.2).

Center of Gravity Limitations

The center of gravity (CG position) for flight conditions must be between the following limits:

Most forward flight CG:

2.350 m (92.52 in) aft of datum plane at 1450 kg (3197 lb)

2.350 m (92.52 in) aft of datum plane at 1468 kg (3236 lb)

2.418 m (95.20 in) aft of datum plane at max. take-off mass 1900 kg (4189 lb)

If MÄM 42-678 is carried out:

2.434 m (95.83 in) aft of datum plane at max. take-off mass 1999 kg (4407 lb)

linear variation in between

Most rearward flight CG:

2.454 m (96.61 in) aft of datum plane at 1450 kg (3197 lb)

2.480 m (97.64 in) aft of datum plane at 1700 kg (3748 lb)

2.480 m (97.64 in) aft of datum plane at max. take-off mass (see Section 2.7)

linear variation in between

Refer to Section 6.4.4 for a graphical illustration of the CG limitations.

WARNING

Exceeding the center of gravity limitations reduces the controllability and stability of the airplane.

2.9 APPROVED MANEUVERS

The airplane is certified in the Normal Category in accordance with JAR-23.

Approved Maneuvers

- 1) All normal flight maneuvers;
- 2) Stalling (with the exception of dynamic stalling); and
- 3) Lazy Eights, Chandelles, as well as steep turns and similar maneuvers, in which an angle of bank of not more than 60° is attained.

CAUTION

Aerobatics, spinning and flight maneuvers with more than 60° of bank are not permitted in the Normal Category. Stalling with asymmetric power or one engine inoperative is not permitted.

CAUTION

Intentional negative g - maneuvers are not permitted.

2.10 MANEUVERING LOAD FACTORS

NOTE

The tables below show structural limitations. The load factor limits for the engine must also be observed. Refer to the corresponding Operation Manual for the engine.

	at v_o	at v_{NE}	with flaps in APP or LDG position
Positive	3.8	3.8	2.0
Negative	-1.52	-1.52	0.0

WARNING

Exceeding the maximum structural load factors will lead to overstressing of the airplane.

CAUTION

Intentional negative g- maneuvers are not permitted.

2.11 OPERATING ALTITUDE

The maximum operating altitude is 18,000 ft (5,486 m) pressure altitude.

2.12 FLIGHT CREW

Minimum crew : 1 (one person)

Maximum number of occupants : 4 (four persons)

2.13 KINDS OF OPERATION

Provided that national operational requirements are met, the following kinds of operation are approved:

- daytime flights according to Visual Flight Rules (VFR)
- with the appropriate equipment: night flights according to Visual Flight Rules (NVFR)
- with the appropriate equipment: flights according to Instrument Flight Rules (IFR)
- take-off and landing on paved surfaces
- take-off and landing on grass surfaces

Flights into known or forecast thunderstorms are prohibited.

Minimum Operational Equipment (Serviceable)

The following table lists the minimum serviceable equipment required by JAR-23. Additional minimum equipment for the intended operation may be required by national operating rules and also depends on the route to be flown.

Doc. No. 7.01.16-E	Rev. 5	10-Jun-2021	EASA approved	Page 2 - 25
--------------------	--------	-------------	------------------	-------------

NOTE

Many of the items of minimum equipment listed in the following table are integrated in the G1000.

	for daytime VFR flights	in addition for night VFR flights	in addition for IFR flights
Flight & navigation instruments	<ul style="list-style-type: none"> * airspeed indicator (on G1000 PFD or backup) * altimeter (on G1000 PFD or backup) * magnetic compass * 1 headset, used by pilot in command 	<ul style="list-style-type: none"> * vertical speed indicator (VSI) * attitude gyro (artificial horizon; on G1000 PFD or backup) * turn & bank indicator (on G1000 PFD) * directional gyro * VHF radio (COM) with speaker and microphone * VOR receiver * transponder (XPDR), mode A and mode C * GPS receiver (part of G1000) 	<ul style="list-style-type: none"> * second airspeed indicator (both, on G1000 PFD and backup) * second altimeter (both, on G1000 PFD and backup) * second attitude gyro (both, on G1000 PFD and backup) * second VHF radio (COM) * VOR-LOC-GP receiver * second GPS receiver (part of G1000)

	for daytime VFR flights	in addition for night VFR flights	in addition for IFR flights
Engine instruments	<ul style="list-style-type: none"> * fuel qty. (2x) * oil press. (2x) * oil temp. (2x) * coolant temp. (2x) * coolant level indicator (2x) * gearbox temp. (2x) * load (2x) * prop. RPM (2x) * fuel temp. left & right tank * fuel flow (2x) * fuel px warning 	<ul style="list-style-type: none"> * ammeter * voltmeter 	
Lighting		<ul style="list-style-type: none"> * position lights * strobe lights (anti collision lights) * landing light * instrument lighting * flood light * flashlight 	

	for daytime VFR flights	in addition for night VFR flights	in addition for IFR flights
Other operational minimum equipment	<ul style="list-style-type: none"> * stall warning system * variable elevator stop * alternate means for fuel quantity indication (see Section 7.9) * safety belts for each occupied seat * Airplane Flight Manual 	<ul style="list-style-type: none"> * Pitot heating system * alternate static valve 	<ul style="list-style-type: none"> * emergency battery (for backup attitude gyro and flood light)

NOTE

A list of approved equipment can be found in Chapter 6.

Engine Systems and Equipment

All engine systems and equipment must be functional prior to airplane take-off. Any engine system or equipment failure must be corrected before next flight.

2.14 FUEL

Approved fuel grades: JET A, JET A-1 (ASTM D 1655)
 TS-1 (Russia, GOST 10227-86)
 TS-1 (Ukraine, GSTU 320.00149943.011-99)
 RT (Russia, GOST 10227-86)
 RT (Ukraine GSTU 320.00149943.007-97)
 No. 3 Jet Fuel (China, GB 6537-2006)
 JP-8 (F34) (USA, MIL-DTL-83133G-2010)

and blends of the above listed fuel grades.

NOTE

A minimum cetane number of 36 determined acc. to EN ISO 5165/ASTM D613 is recommended.

NOTE

Use only uncontaminated fuel from reliable sources.

	Main Tanks		Auxiliary Tanks (if installed)		Total	
	US gal	liters	US gal	liters	US gal	liters
Total fuel quantity	2 x 26.0	2 x 98.4	2 x 13.7	2 x 52.0	2 x 39.7	2 x 150.4
Usable fuel	2 x 25.0	2 x 94.6	2 x 13.2	2 x 50.0	2 x 38.2	2 x 144.6
Max. permissible difference LH/RH	5.0	18.9				

Doc. No. 7.01.16-E	Rev. 5	10-Jun-2021	EASA approved	Page 2 - 29
--------------------	--------	-------------	------------------	-------------

Any mixture of the different types of fuel additives is not permitted.

OPERATION WITH ANTI-MICROBIAL LIFE FUEL ADDITIVES

The application of the following additives is permitted:

- KATHON FP 1.5 : max. 100 ppm
- BIOBOR JF : max. 270 ppm for initial treatment
max. 135 ppm for permanent use after initial treatment

CAUTION

In case of an unknown or an over dosage of the fuel additives the fuel system must be purged until the dosage is within the permitted limits.

NOTE

The specified additives are qualified for the operation with the certified fuel grades.

To clean the fuel system of the airplane a higher dosage of the specified additive is allowed under consideration of the instructions of the additive supplier. During cleaning the engine must not be operated.

NOTE

The instructions of the fuel additive supplier must be followed.

OPERATION WITH ANTI-ICING FUEL ADDITIVES

The application of the following additive is permitted:

- PRIST Hi-Flash : max. 1500 ppm

CAUTION

The use of PRIST Hi-Flash fuel additive is only permitted with JET A, JET A-1 (ASTM D 1655) and JP-8 (F34).

NOTE

The instructions of the fuel additive supplier must be followed.

2.15 LIMITATION PLACARDS

All *limitation* placards are shown below. A list of *all* placards is included in the Airplane Maintenance Manual (Doc. No. 7.02.15), Chapter 11.

The following limitation placards are in the forward view of the pilot:

Limitations for GFC 700 Autopilot System:

Autopilot / Yaw Damper DISC during take-off and landing.

Do not use AP during single engine operation.

Maximum speed for autopilot operation is 180 KIAS.

Minimum speed for autopilot operation is 90 KIAS.

Minimum Altitude for Autopilot Operation:

Cruise, Climb, Descent and Maneuvering : 800 feet AGL

Approach : 200 feet AGL

Departure : 200 feet AGL

This airplane may only be operated in accordance with the Airplane Flight Manual in the "Normal" category. Provided that national operational requirements are met and the appropriate equipment is installed and operational, this airplane is approved for the following kinds of operation: day VFR, night VFR, IFR and flight into known or forecast icing conditions. All aerobatic maneuvers including spinning are prohibited. For further operational limitations refer to the Airplane Flight Manual.

Operating maneuvering speed:

$v_o = 122$ KIAS (above 1800 kg / 3968 lb)

$v_o = 119$ KIAS (above 1700 kg / 3748 lb to 1800 kg / 3968 lb)

$v_o = 112$ KIAS (up to 1700 kg / 3748 lb)

LANDING GEAR $v_{LE} / v_{LOE} = 188 \text{ KIAS}$ $v_{LOR} = 152 \text{ KIAS}$

If OÄM 42-179 is not incorporated:

GPS NOT APPROVED
FOR WAAS OPERATIONS**EMERGENCY
Gear Extension
Max. 152 KIAS**On the Emergency Landing Gear Extension Lever:

On the Instrument Panel:

*Standard Tank:***max. usable
fuel: 2 x 25 US gal**
max. difference LH/RH
tank: 5 US gal*Auxiliary Tank (if installed):***max. usable fuel**
main tank:
2 x 25 US gal
auxiliary tank:
2 x 13 US gal
max. difference LH/RH
main tank: 5 US gal

(a) Next to Each of the Two Fuel Filler Necks:

(b) In Addition Next to Each of the Two Auxiliary Fuel Filler Necks (if installed):

WARNING
APPROVED FUEL
JET-A1
or see Airplane Flight Manual

In Each Cowling, on the Door for the Oil Filler Neck:

OIL
AUSTRO ENGINE
Aero
5W-40
or see Airplane
Flight Manual

OR

OIL
SHELL HELIX
ULTRA
5W30
or see Airplane
Flight Manual

Next to the Flap Selector Switch:

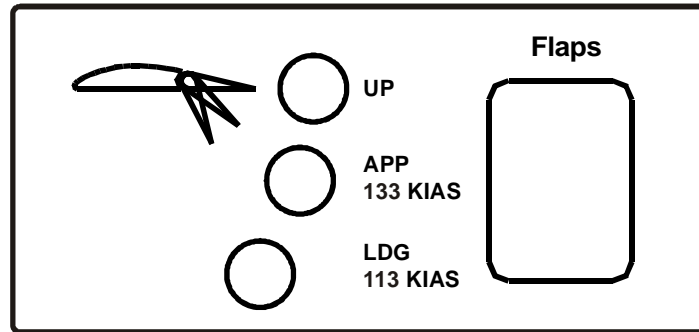

Next to the Cabin Baggage Compartment:

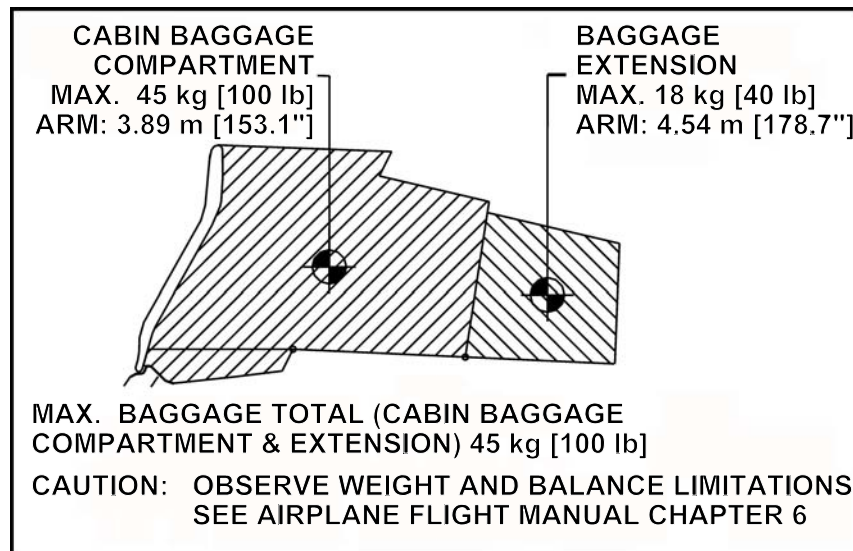

If OÄM 42-207 is carried out:

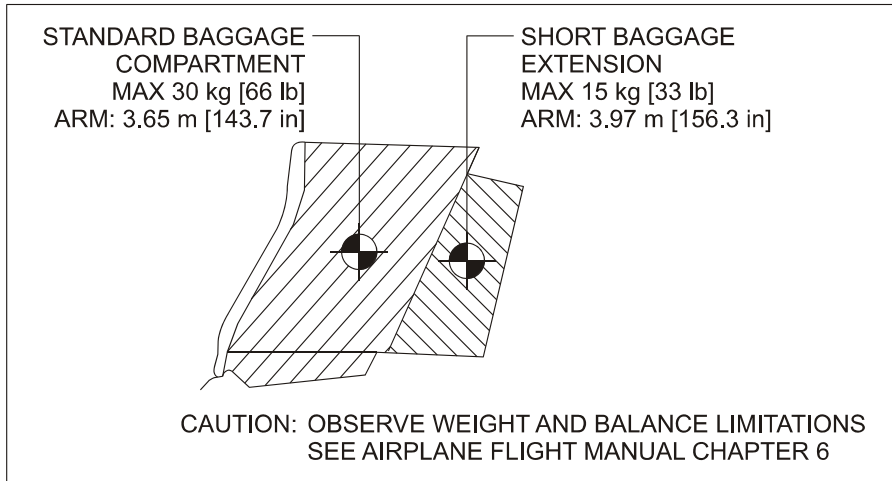

In the Cabin, on the Left Fuselage Sidewall:

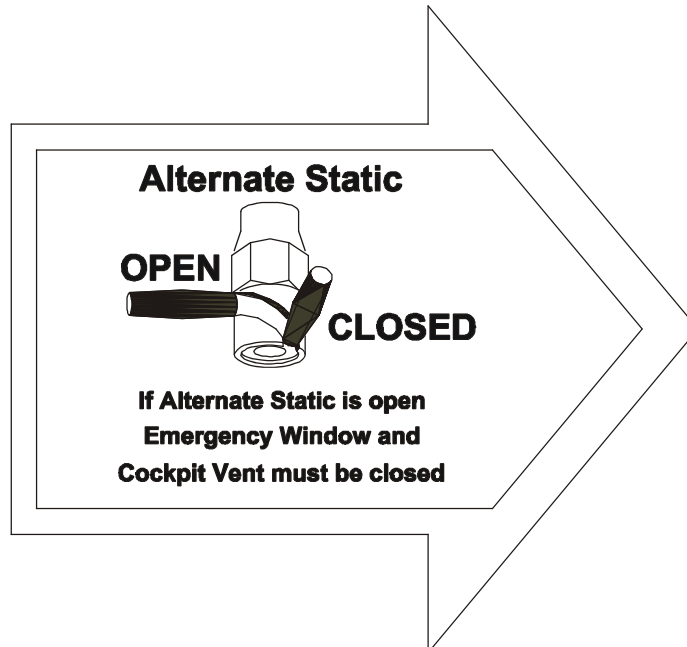

In the Nose Baggage Compartment:

Max. Baggage:
30 kg [66 lb]

Beside the Door Locking Device Installed in the Passengers' Door:

EMERGENCY EXIT:
The keylock must be
unlocked during flight

On the Right-Hand Side of the Instrument Panel Above the Circuit Breakers:

— NO SMOKING —

2.16 OTHER LIMITATIONS

2.16.1 FUEL TEMPERATURE

From -30 °C to 60 °C (from -22 °F to 140 °F).

2.16.2 BATTERY CHARGE

Taking off for a Night VFR or IFR flight with an empty battery is not permitted.

The use of an external power supply for engine starting with an empty airplane battery is also not permitted if the subsequent flight is intended to be a Night VFR or IFR flight. In this case the airplane battery must first be charged.

2.16.3 EMERGENCY SWITCH

IFR flights are not permitted when the seal on the emergency switch is broken.

2.16.4 DOOR LOCKING DEVICE

The canopy and the passenger door must not be blocked by the key lock during operation of the airplane.

2.16.5 PORTABLE ELECTRONIC DEVICES

The use of Portable Electronic Devices (PED) during low visibility approaches is prohibited.

NOTE

Refer to EASA AMC 20-25 or FAA AC 120.76A for the use of PED associated to electronic flight bag (EFB) operation.

The use of any device as an EFB may require separate approvals.

2.16.6 GARMIN G1000 AVIONICS SYSTEM

1. The Garmin G1000 Cockpit Reference Guide, P/N 190-00963-() or Garmin G1000 NXi (MÄM 42-978) Cockpit Reference Guide, P/N 190-02238-() or Garmin G1000 NXi (MÄM 42-1072) Cockpit Reference Guide, P/N 190-02527-(), appropriate revision must be immediately available to the flight crew.
2. The G1000 must utilize the software Garmin 010-00670-(), the Garmin G1000 NXi must utilize the software Garmin 010-01916-(), approved software in accordance with the mandatory service bulletin DAI MSB 42-003, latest approved version.

Software Part Number	Approved Version	Function
System (G1000)	for approved version see DAI MSB 42NG-003 latest version	
010-00670-()		
System (G1000 NXi)		
010-01916-()		
Manifest		
006-B0093-()		GPS1, GPS2
006-B0172-()		GTX1-GIA1, GTX1-GIA2
006-B0190-()		GIA1, GIA2
006-B0193-()		GEA1-GIA1; GEA1-GIA2
006-B0203-()		GMA1-GIA1, GMA1-GIA2
006-B0223-()		GRS1-GIA1, GRS1-GIA2
006-B0224-()		GMU1
006-B0319-()		PFD1, MFD1
006-B0328-()		
006-B0329-()		
006-C0048-()		GMU1 FPGA
006-C0049-()		GRS1 FPGA
006-C0055-()		GDC1 FPGA
006-D0159-()		GRS1 MV DB
006-D0202-()		

Software Part Number	Approved Version	Function
006-B0261-()		GDC1-GIA1
006-B0081-()		COM1, COM2
006-B0083-()		GS1, GS2
006-B0082-()		NAV1, NAV2

NOTE

The database version is displayed on the MFD power-up page immediately after system power-up and must be acknowledged. The remaining system software versions can be verified on the AUX group sub-page 5, "AUX-SYSTEM STATUS".

3. IFR enroute, oceanic and terminal navigation predicated upon the G1000 GPS Receiver is prohibited unless the pilot verifies the currency of the database or verifies each selected way point for accuracy by reference to current approved data.
4. Instrument approach navigation predicated upon the G1000 GPS Receiver must be accomplished in accordance with approved instrument approach procedures that are retrieved from the GPS equipment database. The GPS equipment database must incorporate the current update cycle.

NOTE

Not all published approaches are in the FMS database. The pilot must ensure that the planned approach is in the database.

- (a) Instrument approaches utilizing the GPS receiver must be conducted in the approach mode and Receiver Autonomous Integrity Monitoring (RAIM) must be available at the Final Approach Fix.

Doc. No. 7.01.16-E	Rev. 5	10-Jun-2021	EASA approved	Page 2 - 41
--------------------	--------	-------------	------------------	-------------

- (b) Accomplishment of ILS, LOC, LOC-BC, LDA, SDF, MLS or any other type of approach not approved for GPS overlay with the G1000 GPS receiver is not authorized.
- (c) Use of the G1000 VOR/ILS receiver to fly approaches not approved for GPS require VOR/ILS navigation data to be present on the display.
- (d) When an alternate airport is required by the applicable operating rules, it must be served by an approach based on other than GPS or Loran-C navigation, the airplane must have the operational equipment capable of using that navigation aid, and the required navigation aid must be operational.
- (e) VNAV information may be utilized for advisory information only. Use of VNAV information for Instrument Approach Procedures does not guarantee step-down fix altitude protection, or arrival at approach minimums in normal position to land.
- (f) RNAV (GPS) approaches must be conducted utilizing the GPS sensor.
- (g) RNP RNAV operations are not authorized, except as noted in Chapter 1 of this AFM.

5. If not previously defined, the following default settings must be made in the "SYSTEM SETUP" menu of the G1000 prior to operation (refer to Pilot's Guide for procedure if necessary):
- (a) DIS, SPD : nm, kt (sets navigation units to "nautical miles" and "knots")
 - (b) ALT, VS : ft, fpm (sets altitude units to "feet" and "feet per minute")
 - (c) POSITION : deg-min (sets navigation grid units to decimal minutes)

NOTE

Navigation Information is referenced to WGS-84 reference system, and should only be used where the Aeronautical Information Publication (including electronic data and aeronautical charts) conforms to WGS-84 or equivalent.

6. When AHRS is required to meet the items listed in the minimum operational equipment (serviceable) table in Section 2.13 of this AFM, operation is prohibited in the following areas:
- (a) North of 72° N latitude at all longitudes.
 - (b) South of 70° S latitude at all longitudes.
 - (c) North of 65° N latitude between longitude 75° W and 120° W (Northern Canada).
 - (d) North of 70° N latitude between longitude 70° W and 128° W (Northern Canada).
 - (e) North of 70° N latitude between longitude 85° E and 114° E (Northern Russia).
 - (f) South of 55° S latitude between longitude 120° E and 165° E (Region south of Australia and New Zealand).

When day VFR operations are conducted in the above areas, the MFD must be in a non-heading up orientation.

7. The fuel quantity, fuel required, and fuel remaining functions of the FMS are supplemental information only and must be verified by the flight crew.
8. The GPS is not approved for WAAS operations:
 - (a) The G1000 integrated avionics system is NOT approved for GPS WAAS operations including GPS WAAS approach procedures such as "LPV", "LNAV/VNAV", and "LNAV +V".
 - (b) SBAS (WAAS & MSAS) functionality must be disabled on the G 1000 GPS Status page (refer to the G1000 Pilot's Guide for procedure).
9. The availability of SafeTaxi[®], ChartView, or FliteCharts[®] in electronic form on the G1000 is for information purposes only, it is still mandatory to carry another source of charts on-board the airplane.

2.16.7 AUTOPILOT LIMITATIONS

1. It is the responsibility of the pilot in command to monitor the autopilot when it is engaged. The pilot should be prepared to immediately disconnect the autopilot and to take prompt corrective action in the event of unexpected or unusual autopilot behavior.
2. The autopilot and yaw damper must be disconnected (using the DISC button) during take-off, landing and single engine operation.
3. Following an autopilot or electric trim malfunction, reengaging the autopilot or manual electric trim, or resetting the AFCS / ESP / USP circuit breaker is prohibited until the cause of the malfunction has been determined and corrected.
4. The Garmin G1000 Cockpit Reference Guide for the Diamond DA 42 NG, P/N 010-00963-() or Garmin G1000 NXi (MÄM 42-978) Cockpit Reference Guide for the Diamond DA 42 NG, P/N 010-02238-() or Garmin G1000 NXi (MÄM 42-1072) Cockpit Reference Guide for the Diamond DA 42 NG, P/N 010-02527-() approved revision must be immediately available to the flight crew.
5. ILS approaches using the GFC700 / flight director are limited to Category I approaches only.
6. Autopilot maximum airspeed: 180 KIAS
Autopilot minimum airspeed: 90 KIAS
7. Altitude select captures below 1200 feet AGL are prohibited.
8. The autopilot must be disengaged:
 - below 200 ft AGL during approach,
 - below 200 ft AGL during departure,
 - below 800 ft AGL for all other phases of flight,
 - during single engine operation.
9. Overriding the autopilot to change pitch or roll attitude is prohibited. (Disengage or

press CWS while maneuvering.)

10. The GFC 700 components must utilize the following or later approved software versions:

Sub-System	Software Version
GDU	v9.03
GDC 74	v3.02
GEA 7X	v2.07
GPS	v3.03
GIA 6X	v5.65
GIA Audio	v2.03
GMAX347	v4.01
GMU44	v2.01
GRS 77	v2.11
GTX 33X	v5.01
GDL 69	v3.20.00
GSA 8X	v2.20
GFC 700	v2.00

The system software versions can be verified on the AUX group sub-page 5, "AUX - SYSTEM STATUS".

11. The GFC 700 AFCS pre-flight test must be successfully completed prior to use of the autopilot, flight director, yaw damper or manual electric trim.
12. A pilot with the seat belt fastened must occupy the left pilot's seat during all operations.
13. The yaw damper is an integral part of the autopilot system and must not be used separately.

2.16.8 SMOKING

Smoking in the airplane is not permitted.

2.16.9 GROUND OPERATION

Take-off and landing has been demonstrated on hard paved surfaces (asphalt, concrete, etc.) and grass runways.

2.16.10 USE OF THE SUN VISORS

The sun visors (if installed, OÄM 42-101 or OÄM 42-142) may only be used during cruise. During all other phases of flight the sun visors must be locked in the fully upward position.

2.16.11 GARMIN GWX 68 / GWX 70 WEATHER RADAR OPERATION**WARNING**

The Garmin GWX 68 and the GWX 70 weather radar system (if installed) must not be operated on ground. If the system is transmitting, it may result in bodily injury if persons are within the minimum safe distance of 2.8 m (9.16 ft) for the GWX 68. For the GWX 70 the minimum safe distance is 2.3 m (7.4 ft). Never operate the radar in a hangar or other enclosure as radiation can be reflected throughout the area.

2.16.12 MID CONTINENT MD302 STANDBY ATTITUDE MODULE

The Mid Continent MD302 Standby Attitude Module Pilot's Guide, P/N 9017846, latest effective issue must be immediately available to the flight crew.

Intentionally left blank.

CHAPTER 3

EMERGENCY PROCEDURES

	Page
3.1 INTRODUCTION	3-4
3.1.1 GENERAL	3-4
3.1.2 CERTAIN AIRSPEEDS IN EMERGENCIES	3-5
3.1.3 SELECTING EMERGENCY FREQUENCY	3-5
3.2 AIRPLANE-RELATED G1000 WARNINGS	3-6
3.2.1 WARNINGS / GENERAL	3-6
3.2.2 L/R ENG TEMP	3-6
3.2.3 L/R OIL TEMP	3-8
3.2.4 L/R OIL PRES	3-9
3.2.5 L/R GBOX TEMP	3-10
3.2.6 L/R FUEL TEMP	3-11
3.2.7 L/R FUEL PRESS	3-12
3.2.8 L/R ALTN AMPS	3-12
3.2.9 L/R ENG FIRE	3-13
3.2.10 L/R STARTER	3-14
3.2.11 DOOR OPEN	3-14
3.3 AIRPLANE-RELATED G1000 CAUTIONS	3-15
3.3.1 L/R ALTN FAIL	3-15
3.4 G1000 SYSTEM WARNINGS	3-16
3.4.1 RED X / YELLOW X	3-16
3.4.2 ATTITUDE FAIL	3-16
3.4.3 AIRSPEED FAIL	3-16
3.4.4 ALTITUDE FAIL	3-16
3.4.5 VERT SPEED FAIL	3-17
3.4.6 HDG	3-17

3.5	G1000 FAILURES	3-18
3.5.1	NAVIGATION INFORMATION FAILURE	3-18
3.5.2	PFD OR MFD DISPLAY FAILURE	3-18
3.5.3	AHRS FAILURE	3-19
3.5.4	AIR DATA COMPUTER (ADC) FAILURE	3-20
3.5.5	ERRONEOUS OR LOSS OF ENGINE AND FUEL DISPLAYS	3-20
3.5.6	ERRONEOUS OR LOSS OF WARNING/CAUTION ANNUNCIATORS	3-21
3.6	ABNORMAL ENGINE BEHAVIOUR	3-22
3.7	ONE ENGINE INOPERATIVE PROCEDURES	3-23
3.7.1	DETECTING THE INOPERATIVE ENGINE	3-24
3.7.2	ENGINE TROUBLESHOOTING	3-25
3.7.3	ENGINE SECURING (FEATHERING) PROCEDURE	3-28
3.7.4	UNFEATHERING & RESTARTING THE ENGINE IN FLIGHT	3-29
3.7.5	ENGINE FAILURE DURING TAKE-OFF	3-33
3.7.6	ENGINE FAILURES IN FLIGHT	3-36
3.7.7	LANDING WITH ONE ENGINE INOPERATIVE	3-38
3.7.8	GO-AROUND / BALKED LANDING WITH ONE ENGINE INOPERATIVE	3-41
3.7.9	FLIGHT WITH ONE ENGINE INOPERATIVE	3-44
3.8	ENGINES OUT LANDING	3-46
3.9	LANDING GEAR SYSTEM FAILURES	3-48
3.9.1	LANDING GEAR UNSAFE WARNING	3-48
3.9.2	MANUAL EXTENSION OF THE LANDING GEAR	3-50
3.9.3	LANDING WITH GEAR UP	3-52
3.9.4	LANDING WITH A DEFECTIVE TIRE ON THE MAIN LANDING GEAR	3-53
3.9.5	LANDING WITH DEFECTIVE BRAKES	3-54
3.10	FAILURES IN THE ELECTRICAL SYSTEM	3-55

- 3.10.1 COMPLETE FAILURE OF THE ELECTRICAL SYSTEM . . 3-55
- 3.10.2 HIGH CURRENT 3-56
- 3.10.3 STARTER MALFUNCTION 3-57
- 3.11 SMOKE AND FIRE 3-58
 - 3.11.1 ENGINE FIRE ON GROUND 3-58
 - 3.11.2 ENGINE FIRE DURING TAKE-OFF 3-59
 - 3.11.3 ENGINE FIRE IN FLIGHT 3-60
 - 3.11.4 ELECTRICAL FIRE ON GROUND 3-61
 - 3.11.5 ELECTRICAL FIRE IN FLIGHT 3-62
- 3.12 OTHER EMERGENCIES 3-63
 - 3.12.1 SUSPICION OF CARBON MONOXIDE CONTAMINATION IN
THE CABIN 3-63
 - 3.12.2 UNLOCKED DOORS 3-64
 - 3.12.3 DEFECTIVE PROPELLER RPM REGULATING SYSTEM
. 3-66
 - 3.12.4 UNINTENTIONAL FLIGHT INTO ICING 3-69
 - 3.12.5 FUEL SUPPLY FAILURE 3-70
 - 3.12.6 RECOVERY FROM AN UNINTENTIONAL SPIN 3-71
 - 3.12.7 EMERGENCY DESCENT 3-73
 - 3.12.8 EMERGENCY EXIT 3-73
 - 3.12.9 AUTOPILOT OR ELECTRIC TRIM MALFUNCTION / FAILURE
. 3-74

NOTE

Procedures for uncritical system faults are given in Chapter
4B - ABNORMAL OPERATING PROCEDURES.

3.1 INTRODUCTION

3.1.1 GENERAL

This chapter contains checklists as well as the description of recommended procedures to be followed in the event of an emergency. Engine failure or other airplane-related emergencies are most unlikely to occur if the prescribed procedures for pre-flight checks and airplane maintenance are followed.

If, nonetheless, an emergency does arise, the guidelines given in this chapter should be followed and applied in order to clear the problem.

As it is impossible to foresee all kinds of emergencies and cover them in this Airplane Flight Manual, a thorough understanding of the airplane by the pilot is, in addition to his knowledge and experience, an essential factor in the solution of any problems which may arise.

WARNING

In each emergency, control over the flight attitude and the preparation of a possible emergency landing have priority over attempts to solve the current problem ("first fly the airplane"). Prior to the flight the pilot must consider the suitability of the terrain for an emergency landing for each phase of the flight. For a safe flight the pilot must constantly keep a safe minimum flight altitude. Solutions for various adverse scenarios should be thought over in advance. This should prevent a situation where the pilot is faced with an emergency he cannot handle calmly and with determination.

3.1.2 CERTAIN AIRSPEEDS IN EMERGENCIES

Event		
One engine inoperative minimum control speed (air) v_{MCA}	Flaps UP	71 KIAS
	Flaps APP	68 KIAS
One engine inoperative speed for best rate of climb v_{YSE}	85 KIAS	

3.1.3 SELECTING EMERGENCY FREQUENCY

In an in-flight emergency, depressing and holding the Com transfer button \leftrightarrow on the G1000 for 2 seconds will tune the emergency frequency of 121.500 MHz. If the display is available, it will also show it in the "Active" frequency window.

3.2 AIRPLANE-RELATED G1000 WARNINGS

3.2.1 WARNINGS / GENERAL

"Warning" means that the non-observation of the corresponding procedure leads to an immediate or important degradation in flight safety. The warning text is displayed in red color. A warning chime tone of 1.5 seconds duration will sound and repeat without delay until the alarm is acknowledged by the crew.

3.2.2 L/R ENG TEMP

L/R ENG TEMP	Left / Right engine coolant temperature is in the upper red range (too high / above 105 °C)
---------------------	---

Coolant temperatures above the limit value of 105 °C can lead to a total loss of power due to engine failure.

- Check G1000 for L/R COOL LVL caution message (low coolant level)

L/R COOL LVL caution message not displayed:

During climb:

- Reduce power on affected engine by 10 % or more as required.
- Increase airspeed by 10 KIAS or more as required.
- If the coolant temperature does not reach the green range within 60 seconds, reduce power on affected engine as far as possible and increase airspeed.

CONTINUED

Page 3 - 6	Rev. 5	10-Jun-2021	Doc. No. 7.01.16-E
------------	--------	-------------	--------------------

During cruise:

- Reduce power on affected engine.
- Increase airspeed.
- Check coolant temperature in green range.

CAUTION

If high coolant temperature is indicated and the L/R COOL LVL caution message is not displayed, it can be assumed that there is no technical defect in the cooling system and that the above mentioned procedure can decrease the temperature(s). This might not be the case if the coolant temperature does not return to the green range. In this case perform a precautionary landing on the nearest suitable airfield. Prepare for an engine failure in accordance with 3.7.6 - ENGINE FAILURES IN FLIGHT.

END OF CHECKLIST

L/R COOL LVL caution message displayed:

- Reduce power on affected engine.
- Expect loss of coolant.

WARNING

A further increase in coolant temperature must be expected. Prepare for an engine failure in accordance with 3.7.6 - ENGINE FAILURES IN FLIGHT.

END OF CHECKLIST

3.2.3 L/R OIL TEMP

L/R OIL TEMP	Left / Right engine oil temperature is in the upper red range (too high / above 140 °C).
---------------------	--

Oil temperatures above the limit value of 140 °C can lead to a total loss of power due to engine failure.

- Check oil pressure.

If the oil pressure is outside of the green range (lower limit):

- Reduce power on affected engine.
- Expect loss of engine oil.

WARNING

A further increase in oil temperature must be expected.
Prepare for an engine failure in accordance with
3.7.6 - ENGINE FAILURES IN FLIGHT.

If the oil pressure is within the green range:

- Reduce power on affected engine.
- Increase airspeed.

CONTINUED

Page 3 - 8	Rev. 5	10-Jun-2021	Doc. No. 7.01.16-E
------------	--------	-------------	--------------------

CAUTION

If high oil temperature is announced and the oil pressure indication is within the green range, it can be assumed that there is no technical defect in the engine oil system and that the above mentioned procedure can decrease the temperature(s). This might not be the case if the oil temperature does not return to the green range. In this case perform a precautionary landing on the nearest suitable airfield. Prepare for an engine failure in accordance with 3.7.6 - ENGINE FAILURES IN FLIGHT.

END OF CHECKLIST

3.2.4 L/R OIL PRES

L/R OIL PRES	Left / Right engine oil pressure is in the lower red range (too low / below 0.9 bar).
---------------------	---

Oil pressures below the limit value of 0.9 bar can lead to a total loss of power due to engine failure.

- Reduce power on affected engine.
- Expect loss of oil.

WARNING

Land at the nearest suitable airfield. Prepare for an engine failure in accordance with 3.7.6 - ENGINE FAILURES IN FLIGHT.

END OF CHECKLIST

Doc. No. 7.01.16-E	Rev. 5	10-Jun-2021	Page 3 - 9
--------------------	--------	-------------	------------

3.2.5 L/R GBOX TEMP

L/R GBOX TEMP	Left / Right engine gearbox temperature is in the upper red range (too high / above 120 °C).
----------------------	--

Gearbox temperatures above the limit value of 120 °C can lead to a total loss of power due to engine failure.

- Reduce power on affected engine.
- Increase airspeed.

CAUTION

At high ambient temperature conditions and/or at low airspeeds with high power settings, it can be assumed that there is no technical defect in the gearbox and that the above mentioned procedure will decrease the temperature(s). This might not be the case if the gearbox temperature does not return to the green range. In this case perform a precautionary landing on the nearest suitable airfield. Prepare for an engine failure in accordance with 3.7.6 - ENGINE FAILURES IN FLIGHT.

END OF CHECKLIST

3.2.6 L/R FUEL TEMP

L/R FUEL TEMP	Left / Right fuel temperature is in the upper red range (too high / above 60 °C).
----------------------	---

Fuel temperatures above the limit value of 60 °C can lead to a noticeable reduction of the high pressure pump efficiency.

- Reduce power on affected engine.
- Increase airspeed.

CAUTION

At high ambient temperature conditions and/or at low airspeeds with high power settings and low fuel quantities, it can be assumed that the above mentioned procedure will decrease the temperature(s). If the fuel temperature does not return to the green range, perform a precautionary landing on the nearest suitable airfield.

NOTE

Increased fuel temperature can occur when the fuel quantity in the main tank is low. If the auxiliary tank is installed the fuel temperature can be decreased by transferring fuel from the auxiliary to the main tank.

END OF CHECKLIST

3.2.7 L/R FUEL PRESS

L/R FUEL PRESS	Left / Right engine fuel pressure is low.
-----------------------	---

1. Fuel quantity check
2. FUEL SELECTOR of affected engine check ON
3. Fuel pump of affected engine ON

if L/R FUEL PRESS warning remains:

4. FUEL SELECTOR of affected engine CROSSFEED

if L/R FUEL PRESS warning still remains:

WARNING

Imminent engine failure must be expected. Prepare for an engine failure in accordance with 3.7.6 - ENGINE FAILURE IN FLIGHT.

END OF CHECKLIST

3.2.8 L/R ALTN AMPS

L/R ALTN AMPS	Left / Right engine alternator output is in the upper red range (too high / above 70 Amps).
----------------------	---

Proceed according to:

3.10.2 - HIGH CURRENT

END OF CHECKLIST

Page 3 - 12	Rev. 5	10-Jun-2021	Doc. No. 7.01.16-E
-------------	--------	-------------	--------------------

3.2.9 L/R ENG FIRE**L/R ENG FIRE**

Left / Right engine fire detected.

Engine fire can lead to a total loss of power due to engine failure as well as severe structural damage.

Proceed according to the following procedures as applicable:

3.11.1 - ENGINE FIRE ON GROUND

3.11.2 - ENGINE FIRE DURING TAKE-OFF

3.11.3 - ENGINE FIRE IN FLIGHT

END OF CHECKLIST

3.2.10 L/R STARTER

L/R STARTER	Left / Right engine starter is engaged.
--------------------	---

Proceed according to:

3.10.3 - STARTER MALFUNCTION

END OF CHECKLIST

3.2.11 DOOR OPEN

DOOR OPEN	Front and/or rear canopy and/or baggage door are/is not closed and locked.
------------------	--

Proceed according to:

3.12.2 - UNLOCKED DOORS

END OF CHECKLIST

3.3 AIRPLANE-RELATED G1000 CAUTIONS

3.3.1 L/R ALTN FAIL

L/R ALTN FAIL	Left / Right engine alternator has failed.
----------------------	--

(a) One Alternator Failed

Proceed according to:

4B.4.6 - L/R ALTN FAIL

(b) Both Alternators Failed

WARNING

If both alternators fail at the same time, reduce all electrical equipment to a minimum. Expect battery power to last 30 minutes and land the airplane as soon as possible. Expect engine stoppage after this period of time.

1. AVIONICS MASTER OFF
2. LH / RH Alternator OFF
3. XPDR STBY
4. LANDING GEAR down, when down and locked pull
Emergency Release
5. Stall / Pitot heat OFF
6. All lights OFF

END OF CHECKLIST

Doc. No. 7.01.16-E	Rev. 5	10-Jun-2021	Page 3 - 15
--------------------	--------	-------------	-------------

3.4 G1000 SYSTEM WARNINGS

3.4.1 RED X / YELLOW X

A red or yellow X through any display field, such as COM frequencies, NAV frequencies, or engine data, indicates that display field is not receiving valid data.

3.4.2 ATTITUDE FAIL

ATTITUDE FAIL	The display system is not receiving attitude reference information from the AHRS; accompanied by the removal of sky/ground presentation and a red X over the attitude area.
----------------------	---

Revert to the standby attitude indicator.

3.4.3 AIRSPEED FAIL

AIRSPEED FAIL	The display system is not receiving airspeed input from the air data computer; accompanied by a red X through the airspeed display.
----------------------	---

Revert to the standby airspeed indicator.

3.4.4 ALTITUDE FAIL

ALTITUDE FAIL	The display system is not receiving altitude input from the air data computer; accompanied by a red X through the altimeter display.
----------------------	--

Revert to the standby altimeter.

3.4.5 VERT SPEED FAIL**VERT SPEED FAIL**

The display system is not receiving vertical speed input from the air data computer; accompanied by a red or yellow X through the vertical speed display.

Determine vertical speed based on the change of altitude information.

3.4.6 HDG**HDG**

The display system is not receiving valid heading input from the AHRS; accompanied by a red X through the digital heading display.

Revert to the emergency compass.

3.5 G1000 FAILURES

3.5.1 NAVIGATION INFORMATION FAILURE

If Garmin G1000 GPS navigation information is not available or invalid, utilize remaining operational navigation equipment as required.

3.5.2 PFD OR MFD DISPLAY FAILURE

1. DISPLAY BACKUP button on audio panel . . PUSH

Automatic Entry of Display Reversionary Mode

If the PFD and MFD have automatically entered reversionary mode, use the following procedure.

- (a) DISPLAY BACKUP button on audio panel PUSH (button will be OUT)

NOTE

After automatic entry of reversionary mode, the pilot must press the DISPLAY BACKUP button on the audio panel. After the DISPLAY BACKUP button has been pushed, the system will remain in reversionary mode even if the problem causing the automatic entry of reversionary mode is resolved. A maximum of one attempt to return to normal mode is approved using the following procedure.

CONTINUED

(b) DISPLAY BACKUP button on audio panel PUSH (button will be IN)

- If the system returns to normal mode, leave the DISPLAY BACKUP button IN and continue.
- If the system remains in reversionary mode, or abnormal display behavior such as display flashing occurs, then return the DISPLAY BACKUP button to the OUT position.

END OF CHECKLIST

3.5.3 AHRS FAILURE

NOTE

A failure of the Attitude and Heading Reference System (AHRS) is indicated by a removal of the sky/ground presentation and a red X and a yellow "AHRS FAILURE" shown on the PFD. The digital heading presentation will be replaced with a yellow "HDG" and the compass rose digits will be removed. The course pointer will indicate straight up and course may be set using the digital window.

1. Use standby attitude indicator, emergency compass and navigation map
2. Course set using digital window

END OF CHECKLIST

3.5.4 AIR DATA COMPUTER (ADC) FAILURE

NOTE

Complete loss of the Air Data Computer is indicated by a red X and yellow text over the airspeed, altimeter, vertical speed, TAS and OAT displays. Some FMS functions, such as true airspeed and wind calculations, will also be lost.

1. Use standby airspeed indicator and altimeter.

END OF CHECKLIST

3.5.5 ERRONEOUS OR LOSS OF ENGINE AND FUEL DISPLAYS

NOTE

Loss of an engine parameter is indicated by a red or yellow X through the data field. Erroneous information may be identified by indications which do not agree with other system information. Erroneous indications may be determined by comparing a display with other displays and other system information.

1. Set power based on power lever position, engine noise and speed.
2. Monitor other indications to determine the health of the engine.
3. Use known power settings and Section 5.3.2 of the AFM for approximate fuel flow values.
4. Use other system information, such as annunciator messages, GPS fuel quantity and flow to safely complete the flight.

END OF CHECKLIST

3.5.6 ERRONEOUS OR LOSS OF WARNING/CAUTION ANNUNCIATORS**NOTE**

Loss of an annunciator may be indicated when engine or fuel displays show an abnormal or emergency situation and the annunciator is not present. An erroneous annunciator may be identified when an annunciator appears which does not agree with other displays or system information.

1. If an annunciator appears, treat it as if the condition exists.
Refer to Chapter 3 - EMERGENCY PROCEDURES or Chapter 4B -ABNORMAL OPERATING PROCEDURES.
2. If a display indicates an abnormal condition but no annunciator is present, use other system information, such as engine displays, GPS fuel quantity and flow to determine if the condition exists. If it cannot be determined that the condition does not exist, treat the situation as if the condition exists.
Refer to Chapter 3 - EMERGENCY PROCEDURES or Chapter 4B - ABNORMAL OPERATING PROCEDURES.

END OF CHECKLIST

3.6 ABNORMAL ENGINE BEHAVIOUR

1. Full power apply

If the abnormal engine behavior sustains, refer to 3.7 - ONE ENGINE INOPERATIVE PROCEDURES.

END OF CHECKLIST

3.7 ONE ENGINE INOPERATIVE PROCEDURES

WARNING

In certain combinations of airplane weight, configuration, ambient conditions, speed and pilot skill, negative climb performance may result. Refer to Chapter 5 - PERFORMANCE for one engine inoperative performance data.

In any event the sudden application of power during one-engine inoperative operation makes the control of the airplane more difficult.

3.7.1 DETECTING THE INOPERATIVE ENGINE

NOTE

One engine inoperative means an asymmetric loss of thrust, resulting in uncommanded yaw and roll in direction of the so-called "dead" engine (with coordinated controls). To handle this situation it is vital to maintain directional control by mainly rudder and additional aileron input. The following mnemonic can help to identify the failed engine:

"Dead foot - dead engine"

This means that, once directional control is re-established, the pilot can feel the control force on the foot pushing the rudder-pedal on the side of the operative engine, while the foot on the side of the failed engine feels no force. Further, the engine instruments can help to analyze the situation.

3.7.2 ENGINE TROUBLESHOOTING

WARNING

Control over the flight attitude has priority over attempts to solve the current problem ("first fly the airplane").

NOTE

With respect to handling and performance, the left-hand engine (pilots view) is considered the "critical" engine.

If both ECU A and ECU B Cautions Appear Simultaneous

- if the indicated LOAD remains unchanged, and
 - if the perceived thrust is reduced, and
 - if the engine noise level changes or the engine is running rough
1. POWER lever IDLE for 1 second
 2. POWER lever slowly increase to 1975 RPM

If the engine shows a power loss during the POWER lever increases:

3. POWER lever IDLE for 1 second
4. POWER lever slowly increase, stop prior to the former observed engine power loss RPM

CONTINUED

WARNING

Do not increase the POWER lever past the propeller speed of 1975 RPM or the setting determined in step 4. An increase of engine power beyond this setting leads into another power loss.

NOTE

With this power setting the engine can provide up to 65% at the maximum propeller speed of 1975 RPM.

5. Land at the next suitable airfield

Otherwise:

NOTE

If the loss of power was due to unintentional setting of the POWER lever, you may adjust the friction lock and continue flight.

Depending on the situation the following attempts can be made to restore normal engine operation:

1. Circuit breakers check / reset if necessary

If normal engine operation is restored continue flight and land as soon as possible.

Otherwise:

2. VOTER switch swap between ECU A and B

CONTINUED

If either ECU A or B setting restores normal engine operation then maintain that ECU setting and land as soon as possible.

Otherwise:

- 3. VOTER switch switch back to AUTO to retain ECU redundancy

If normal engine operation is restored continue flight and land as soon as possible.

Otherwise:

- 4. FUEL SELECTOR of affected engine CROSSFEED

If normal engine operation is restored continue flight. Remain within maximum allowable lateral imbalance.

Otherwise:

- 5. FUEL SELECTOR of affected engine ON / CROSSFEED as required
- 6. ALTERNATE AIR OPEN
- 7. POWER lever of affected engine apply power as required

If normal engine operation is restored continue flight and land as soon as practicable.

If normal engine operation could not be restored by following the procedures in this section prepare for 3.7.3 - ENGINE SECURING (FEATHERING) PROCEDURE and land as soon as possible.

END OF CHECKLIST

3.7.3 ENGINE SECURING (FEATHERING) PROCEDURE

Shut down and feathering of the affected engine:

1. Affected engine identify & verify
2. ENGINE MASTER affected engine OFF

CAUTION

Do not shut down an engine with the FUEL SELECTOR valve.
Otherwise the high pressure fuel pump can be damaged.

Securing the feathered engine:

3. Alternator affected engine OFF
4. Fuel pump check OFF
5. FUEL SELECTOR affected engine OFF

NOTE

The remaining fuel in the tank of the secured engine can be used for the remaining engine to extend range and maintain lateral balance by setting the FUEL SELECTOR of the remaining engine to the CROSSFEED position.

If one of the POWER levers is set to low settings the landing gear warning horn is activated. Set the POWER lever of the secured engine forward as required to mute the warning horn.

END OF CHECKLIST

3.7.4 UNFEATHERING & RESTARTING THE ENGINE IN FLIGHT

If the reason for the shutdown has been ascertained and there is no indication of malfunction or engine fire a restart may be attempted.

Restarting the Engine with the Starter

Maximum restart altitude: 18,000 ft pressure altitude
for immediate restart.
10,000 ft pressure altitude
for restarts within two minutes.

If MÄM 42-938 (engine software
VC33_2_05_19 or later approved
software) is installed:

15,000 ft pressure altitude
for immediate restarts
Up to 10,000 ft pressure altitude:

OAT		Max. engine OFF time [minutes]
[° C]	[° F]	
below -15	below 5	2
-15 to -5	5 to 23	5
above -5	above 23	10

Maximum restart airspeed: max. 100 KIAS or airspeed for a stationary
propeller, whichever is lower.

CAUTION

Do not engage the starter when the propeller is windmilling.

CONTINUED

Doc. No. 7.01.16-E	Rev. 5	10-Jun-2021	Page 3 - 29
--------------------	--------	-------------	-------------

NOTE

At airspeeds below 100 KIAS it is possible that the propeller may windmill intermittently. Therefore, care should be taken to ensure that the propeller is stationary when engaging the starter.

1. POWER lever of affected engine IDLE
2. FUEL SELECTOR of affected engine check ON
3. Alternate air as required
4. ALTERNATOR of affected engine ON
5. ENGINE MASTER of affected engine ON, propeller un-feathers
6. STARTER of affected engine engage when propeller is stationary

CAUTION

After the engine has started, the POWER lever should be set to a moderate power setting until engine temperatures have reached the green range.

7. Circuit breakers check / reset if necessary

END OF CHECKLIST

Restarting the Engine by Windmilling

If the reason for the shutdown has been ascertained and there is no indication of malfunction or engine fire a restart may be attempted.

Maximum restart altitude: 18,000 ft pressure altitude
 for immediate restart.
 10,000 ft pressure altitude
 for restarts within two minutes.

If MÄM 42-938 (engine software
 VC33_2_05_19 or later approved
 software) is installed:

15,000 ft pressure altitude
 for immediate restarts
 Up to 10,000 ft pressure altitude:

OAT		Max. engine OFF time
[° C]	[° F]	[minutes]
below -15	below 5	2
-15 to -5	5 to 23	5
above -5	above 23	10

Minimum restart airspeed: 125 KIAS
 Maximum restart airspeed: 145 KIAS

CAUTION

1. Do not engage the starter when the propeller is windmilling.
2. Do not attempt restart below 125 KIAS.
3. Do not attempt restart above 145 KIAS.

CONTINUED

Doc. No. 7.01.16-E	Rev. 5	10-Jun-2021	Page 3 - 31
--------------------	--------	-------------	-------------

NOTE

Below 125 KIAS it is possible that the propeller may not windmill continuously. Continuous windmilling is required for a successful restart. Above 145 KIAS a restart can overspeed the propeller.

1. POWER lever of affected engine IDLE
2. FUEL SELECTOR of affected engine check ON
3. Alternate air as required
4. ALTERNATOR of affected engine ON
5. ENGINE MASTER of affected engine ON, propeller un-feathers and restarts by windmilling

CAUTION

After the engine has started, the POWER lever should be set to a moderate power setting until engine temperatures have reached the green range.

CAUTION

After resuming the flight, notify maintenance and make an entry into the airplane Logs, that a windmilling restart was conducted. Conditional engine maintenance requirements for the timing chain are triggered. Refer also to the Austro Engine GmbH Engine Maintenance Manual.

END OF CHECKLIST

3.7.5 ENGINE FAILURE DURING TAKE-OFF

a) Engine Failure During Ground Roll

- Abort take-off.

- 1. POWER lever IDLE / BOTH
- 2. Rudder maintain directional control
- 3. Brakes as required

CAUTION

If sufficient time is remaining, the risk of fire in the event of a collision with obstacles can be reduced as follows:

- 4. ENGINE MASTER both OFF
- 5. FUEL SELECTOR both OFF
- 6. ELECT. MASTER OFF

END OF CHECKLIST

b) Engine Failure After Lift Off

If the landing gear is still extended and the remaining runway / surface is adequate:

- Abort the take-off & land straight ahead.

If the remaining runway / surface is inadequate:

- Decide whether to abort or to continue the take-off.

Continued take-off:

WARNING

A continued take-off is not recommended if the steady rate of climb according to Section 5.3.8 - ONE ENGINE INOPERATIVE CLIMB PERFORMANCE is less than 3.3 %. Under certain combinations of ambient conditions, such as turbulence, crosswinds and wind shear as well as pilot skill the resulting climb performance may nevertheless be insufficient to continue the take-off successfully. Therefore a continued take-off with a failed engine has to be avoided if at all possible.

1. POWER lever MAX
2. Rudder maintain directional control
3. Airspeed $V_{YSE} = 85$ KIAS / as required
4. Landing gear UP to achieve a positive ROC
5. FLAPS check UP

CONTINUED

6. Inoperative engine secure according to
3.7.3 - ENGINE SECURING
(FEATHERING) PROCEDURE

Land as soon as possible according to 3.7.7 - LANDING WITH ONE ENGINE INOPERATIVE. If a diversion is required before landing continue according to Section 3.7.9 - FLIGHT WITH ONE ENGINE INOPERATIVE.

END OF CHECKLIST

3.7.6 ENGINE FAILURES IN FLIGHT

(a) Engine Failure During Initial Climb

WARNING

As the climb is a flight condition which is associated with high power settings, airspeeds lower than $v_{MCA} = 71$ KIAS (flaps UP) or 68 KIAS (flaps APP) should be avoided as a sudden engine failure can lead to loss of control. In this case it is very important to reduce the asymmetry in thrust to regain directional control.

1. Rudder maintain directional control
2. Airspeed $v_{YSE} = 85$ KIAS/
above $v_{MCA} = 71$ KIAS (flaps UP)
or $v_{MCA} = 68$ KIAS (flaps APP) as
required
3. Operative engine increase power as required if
directional control has been
established

Establish minimum / zero sideslip condition. (approx. half ball towards good engine; 3° to 5° bank).

4. Inoperative engine Secure according to 3.7.3 -
ENGINE SECURING
(FEATHERING) PROCEDURE

Land as soon as possible according to 3.7.7 - LANDING WITH ONE ENGINE INOPERATIVE. If a diversion is required before landing continue according to Section 3.7.9 - FLIGHT WITH ONE ENGINE INOPERATIVE.

END OF CHECKLIST

Page 3 - 36	Rev. 5	10-Jun-2021	Doc. No. 7.01.16-E
-------------	--------	-------------	--------------------

(b) Engine Failure During Flight

- 1. Rudder maintain directional control
- 2. Airspeed as required /
above $v_{MCA} = 71$ KIAS (flaps UP)
or $v_{MCA} = 68$ KIAS (flaps APP)
- 3. Operative engine increase power up to 92% load

Establish minimum / zero sideslip condition. (approx. half ball towards good engine; 3° to 5° bank).

- 4. Inoperative engine Secure according to 3.7.3 -
ENGINE SECURING
(FEATHERING) PROCEDURE.

Land as soon as possible according to 3.7.7 - LANDING WITH ONE ENGINE INOPERATIVE. If a diversion is required before landing continue according to Section 3.7.9 - FLIGHT WITH ONE ENGINE INOPERATIVE.

END OF CHECKLIST

3.7.7 LANDING WITH ONE ENGINE INOPERATIVE

Preparation:

CAUTION

For emergency landing the adjustable backrests (if installed) must be fixed in the upright position.

1. Adjustable backrests (if installed) adjust to the upright position described by a placard on the roll-over bar and verify proper fixation
2. Safety harnesses check fastened & tightened
3. Landing light as required
4. Gear warning horn check function

Operative engine:

5. Fuel pump remaining engine ON
6. FUEL SELECTOR check ON

Inoperative engine:

7. Engine check secured (feathered) according to 3.7.3 - ENGINE SECURING & FEATHERING PROCEDURE

CONTINUED

NOTE

Higher approach speeds result in a significantly longer landing distance during flare.

CAUTION

In conditions such as (e.g.) strong wind, danger of wind shear or turbulence a higher approach speed should be selected.

- Perform normal touchdown and deceleration on ground.

END OF CHECKLIST

If the approach to land is not successful you may consider:

3.7.8 GO-AROUND / BALKED LANDING WITH ONE ENGINE INOPERATIVE

CAUTION

The go-around / balked landing is not recommended to be initiated below a minimum of 800 ft above ground.

For performance data with one engine inoperative and flaps and gear UP refer to 5.3.8 - ONE ENGINE INOPERATIVE CLIMB PERFORMANCE.

Under certain combinations of ambient conditions, such as turbulence, cross wind and windshear, as well as pilot skill, the resulting climb performance may nevertheless be insufficient for a successful go-around / balked landing.

1. POWER lever MAX
2. Rudder maintain directional control
3. Airspeed $V_{YSE} = 85$ KIAS / as required
4. Landing gear UP / retract
5. FLAPS UP

- Establish minimum sideslip and manoeuvre for a new attempt to land. Repeat from step 1 of section 3.7.9 - FLIGHT WITH ONE ENGINE INOPERATIVE.

CONTINUED

Doc. No. 7.01.16-E	Rev. 5	10-Jun-2021	Page 3 - 41
--------------------	--------	-------------	-------------

If a positive rate of climb cannot be established:

- Land so as to keep clear of obstacles.

If time allows the following steps can reduce the risk of fire in an event of collision with obstacles after touchdown:

- 6. ENGINE MASTER both OFF
- 7. FUEL SELECTOR both OFF
- 8. FLAPS APP or LDG, as required

NOTE

If landing is performed off airfield, depending on the surface condition it may be beneficial to land with the gear UP. Note that the energy absorbing function of the landing gear is lost in such cases.

NOTE

Extending the gear and extending the flaps to LDG will increase drag and incur a high sink rate. Only when the landing area can be reached safely, landing with flaps LDG is advisable.

- 9. Approach speed:
 - Up to 1900 kg (4189 lb) min. 84 KIAS flaps APP
min. 84 KIAS flaps LDG
 - Above 1900 kg (4189 lb) min. 88 KIAS flaps APP
min. 86 KIAS flaps LDG

CONTINUED

If landing with landing gear extended:

- 10. LANDING GEAR DOWN, check 3 green
- 11. ELECT. MASTER OFF
- 12. Touch down lowest practical speed

If landing with landing gear retracted:

- 10. LANDING GEAR UP
- 11. Touch down lowest practical speed

Immediately after touch down:

- 12. ELECT. MASTER OFF

NOTE

If the ELECT. MASTER is switched OFF before touchdown the landing gear will extend slowly.

END OF CHECKLIST

3.7.9 FLIGHT WITH ONE ENGINE INOPERATIVE

CAUTION

Even if a positive flight performance can be established with one engine inoperative, land as soon as possible at the next suitable airfield / airport.

CAUTION

Prolonged operation with excessive side slip/bank angle may cause fuel starvation, which is normally advised by LOW FUEL indication on the G1000. In this case return to coordinated flight or use CROSSFEED on the affected engine.

1. Airspeed above $v_{MCA} = 71$ KIAS (flaps UP)
or $v_{MCA} = 68$ KIAS (flaps APP) to
maintain directional control
2. Remaining engine monitor engine instruments
continuously
3. Fuel quantity monitor continuously
4. Fuel pump LH/RH check OFF
5. FUEL SELECTOR remaining engine / set
CROSSFEED or ON so as to
keep fuel quantity laterally
balanced

CONTINUED

NOTE

If the FUEL SELECTOR is set on CROSSFEED, the engine will be supplied with fuel from the main tank on the opposite side.

This will extend range and helps to keep the wings laterally balanced (see 2.14 - FUEL).

Land as soon as possible according to Section 3.7.7 - LANDING WITH ONE ENGINE INOPERATIVE.

END OF CHECKLIST

3.8 ENGINES OUT LANDING

1. ENGINE MASTER both OFF
2. Alternator switches both OFF
3. Fuel pumps both OFF
4. FUEL SELECTOR both OFF
5. AVIONIC MASTER OFF
6. Safety harnesses check fastened and tightened

When sure of making landing area:

7. FLAPS APP or LDG, as required

NOTE

If landing is performed off airfield, depending on the surface condition it may be beneficial to land with the gear UP. Note that the energy absorbing function of the landing gear is lost in such cases.

NOTE

Extending the gear and extending the flaps to LDG will increase drag and incur a high sink rate. Only when the landing area can be reached safely, landing with flaps LDG is advisable.

8. Approach speed:
Up to 1900 kg (4189 lb) min. 84 KIAS flaps APP
min. 84 KIAS flaps LDG

Above 1900 kg (4189 lb) min. 88 KIAS flaps APP
min. 86 KIAS flaps LDG

CONTINUED

If landing with landing gear extended:

- 9. LANDING GEAR DOWN, check 3 green
- 10. POWER lever both IDLE
- 11. ELECT. MASTER OFF
- 12. Touch down lowest practical speed

If landing with landing gear retracted:

- 9. LANDING GEAR UP
- 10. POWER lever both IDLE
- 11. Touch down lowest practical speed

Immediately after touch down:

- 12. ELECT. MASTER OFF

END OF CHECKLIST

3.9 LANDING GEAR SYSTEM FAILURES

3.9.1 LANDING GEAR UNSAFE WARNING

NOTE

The landing gear unsafe warning light illuminates if the landing gear is neither in the final up or down & locked position. Illumination of this light is therefore normal during transit.

If the light remains on for longer than 20 seconds during landing gear retraction / extension:

1. Airspeed check below $v_{LOR} = 152$ KIAS
2. Gear selector re-cycle if continued illumination occurs

If the landing gear cannot be extended to the down & locked position or red light does not extinguish:

- Continue with 3.9.2 - MANUAL EXTENSION OF THE LANDING GEAR.

CONTINUED

Page 3 - 48	Rev. 5	10-Jun-2021	Doc. No. 7.01.16-E
-------------	--------	-------------	--------------------

NOTE

If the landing gear cannot be retracted to the final up position you may continue the flight with the landing gear extended in the down & locked position. Consider for higher aerodynamic drag, resulting in degraded flight performance, increased fuel consumption and decreased range.

With the landing gear extended and at aft CG-locations, with flaps up and full power applied, the airplane will easily recover from sideslip if the trim is set to neutral (normal procedure). Otherwise it may require corrective action with a moderate amount of rudder input.

In cold ambient temperatures it may help to reduce the airspeed below 110 KIAS for landing gear operation.

END OF CHECKLIST

3.9.2 MANUAL EXTENSION OF THE LANDING GEAR

NOTE

In case of a failure of the electrical pump, which is driving the landing gear actuators, the landing gear can be extended manually at speeds up to 152 KIAS. The manual extension of the landing gear may take up to 20 seconds.

The following checks shall be completed before extending the landing gear manually:

1. Gear indicator lights test / push test button
2. ELECT. MASTER check ON
3. Bus voltage check in normal range
4. Circuit breaker check in / reset if necessary

Manual landing gear extension procedure:

5. Gear selector select DOWN
6. Manual gear extension handle pull out

NOTE

The landing gear should now extend by gravity and relief of hydraulic pressure from the system. If one or more landing gear indicator lights do not indicate the gear down & locked after completion of the manual extension procedure steps 1 - 6 reduce airspeed below 110 KIAS and apply moderate yawing and pitching to bring the landing gear into the locked position.

CONTINUED

7. Gear indicator lights check 3 green lights

NOTE

If the landing gear is correctly extended and locked, as indicated by the 3 green lights, the red light is illuminated additionally if the GEAR circuit breaker is pulled.

If the landing gear cannot be extended to the down & locked position continue according to 3.9.3 - LANDING WITH GEAR UP.

END OF CHECKLIST

3.9.3 LANDING WITH GEAR UP

NOTE

This procedure applies if the landing gear is completely retracted.

1. Approach with power at normal approach
airspeeds and flap settings
2. POWER lever IDLE / just before
touchdown

If the time / situation allows, the following steps can help to reduce the risk of fire:

3. ENGINE MASTER both OFF
4. Fuel pumps check OFF
5. FUEL SELECTOR both OFF

Touchdown:

6. Touchdown contact surface with minimum
airspeed
7. On ground maintain directional control with
rudder as long as possible so as
to avoid collision with obstacles

Immediately after touchdown:

8. ELECT. MASTER OFF

NOTE

If the ELECT. MASTER is switched OFF before touchdown the landing gear will extend slowly.

END OF CHECKLIST

3.9.4 LANDING WITH A DEFECTIVE TIRE ON THE MAIN LANDING GEAR**CAUTION**

A defective (e.g. burst) tire is not usually easy to detect. The damage normally occurs during take-off or landing, and is hardly noticeable during fast taxiing. It is only during the roll-out after landing or at lower taxiing speeds that a tendency to swerve occurs. Rapid and determined action is then required.

1. Land the airplane at the edge of the runway that is located on the side of the intact tire, so that changes in direction which must be expected during roll-out due to the braking action of the defective tire can be corrected on the runway.
2. Land with one wing low. The wing on the side of the intact tire should be held low.
3. Direction should be maintained using the rudder. This should be supported by use of the brake. It is possible that the brake must be applied strongly - if necessary to the point where the wheel locks. The wide track of the landing gear will prevent the airplane from tipping over a wide speed range. There is no pronounced tendency to tip even when skidding.

END OF CHECKLIST

3.9.5 LANDING WITH DEFECTIVE BRAKES

Consider the greater rolling distance.

1. Safety harness check fastened and tightened

CAUTION

If sufficient time is remaining, the risk of fire in the event of a collision can be reduced as follows after a safe touch-down:

- ENGINE MASTER both OFF
- FUEL SELECTOR both OFF
- ELECT. MASTER OFF

END OF CHECKLIST

3.10 FAILURES IN THE ELECTRICAL SYSTEM

3.10.1 COMPLETE FAILURE OF THE ELECTRICAL SYSTEM

- 1. Circuit breakers check if all OK (pressed in)

If there is still no electrical power available:

- 2. EMERGENCY SWITCH ON
- 3. Flood light, if necessary ON
- 4. POWER set based on lever positions
and engine noise
- 5. Prepare landing with flaps in the given position. Refer to 4B.5 - FAILURES IN
FLAP OPERATING SYSTEM.
- 6. Land on the nearest suitable airfield.

WARNING

Engine stoppage may occur, depending on the failure mode. Backup batteries are installed for the ECUs to provide electrical power solely to the ECU and their systems for at least 30 minutes.

NOTE

The landing gear uplock is no longer ensured. The landing gear may slowly extend.

The landing gear can be extended manually according to 3.9.2 - MANUAL EXTENSION OF THE LANDING GEAR.

CONTINUED

Doc. No. 7.01.16-E	Rev. 5	10-Jun-2021	Page 3 - 55
--------------------	--------	-------------	-------------

NOTE

The backup artificial horizon (or standby attitude module) and the flood light will have electrical power for at least 1.5 hours.

Make use of the stand-by airspeed indicator and altimeter. Engine power can be set via visual reference of the POWER lever position.

END OF CHECKLIST

3.10.2 HIGH CURRENT

If high current is indicated on the G1000:

1. Circuit breakers check
2. Reduce electric load to minimum required for continued safe flight.
3. Land on the nearest suitable airfield.

END OF CHECKLIST

3.10.3 STARTER MALFUNCTION

If the starter does not disengage from the engine after starting (starter engaged warning (STARTER L/R) on the G1000 annunciator field illuminates after the engine has started):

On Ground:

- 1. POWER lever affected engine IDLE
- 2. ENGINE MASTER affected engine OFF
- 3. ELECT. MASTER OFF

Terminate flight preparation.

In flight:

Refer to 3.7.4 - UNFEATHERING & RESTARTING THE ENGINE IN FLIGHT.

If restart is not successful:

Refer to 3.7.9 - FLIGHT WITH ONE ENGINE INOPERATIVE.

END OF CHECKLIST

3.11 SMOKE AND FIRE

NOTE

The cabin hand fire extinguisher is located inside the airplane passenger compartment on the RH side of the cabin floor behind the co-pilot seat.

To release the fire extinguisher bottle out of the bracket, it is necessary to catch the bottle at the agent-outlet nozzle near the Y-spring.

3.11.1 ENGINE FIRE ON GROUND

1. ENGINE MASTER both OFF
2. FUEL SELECTOR both OFF
3. ELECT. MASTER OFF

After standstill:

4. Canopy open
5. Airplane evacuate immediately

END OF CHECKLIST

3.11.2 ENGINE FIRE DURING TAKE-OFF

1. Cabin heat & Defrost OFF

CAUTION

In case of extreme smoke development, the front canopy may be unlatched during flight. This allows it to partially open, in order to improve ventilation. The canopy will remain open in this position. Flight characteristics will not be affected significantly.

Proceed according to 3.7.5 - ENGINE FAILURES DURING TAKE-OFF.

END OF CHECKLIST

3.11.3 ENGINE FIRE IN FLIGHT

1. Cabin heat & Defrost OFF

CAUTION

In case of extreme smoke development, the front canopy may be unlatched during flight. This allows it to partially open, in order to improve ventilation. The canopy will remain open in this position. Flight characteristics will not be affected significantly.

Proceed according to 3.7.6 - ENGINE FAILURES IN FLIGHT and shut down the engine according to 3.7.3 - ENGINE SECURING (FEATHERING) PROCEDURE.

END OF CHECKLIST

3.11.4 ELECTRICAL FIRE ON GROUND

- 1. ELECT. MASTER OFF

If the engine is running:

- 2. POWER lever both IDLE
- 3. ENGINE MASTER both OFF
- 4. FUEL SELECTOR both OFF

When the engine has stopped / after standstill:

- 5. Canopy open
- 6. Airplane evacuate immediately

END OF CHECKLIST

3.11.5 ELECTRICAL FIRE IN FLIGHT

1. EMERGENCY SWITCH ON
2. AVIONIC MASTER OFF
3. ELECT. MASTER OFF
4. Cabin heat & Defrost OFF
5. Emergency windows open if required
6. Land at the next suitable airfield

CAUTION

Switching OFF the ELECT. MASTER will lead to total failure of all electronic and electric equipment. The attitude and heading reference system (AHRS) will also be affected.

However, by switching the EMERGENCY switch ON, the emergency battery will supply power to the standby attitude gyro / module (artificial horizon) and the flood light.

In case of extreme smoke development, the front canopy may be unlatched during flight. This allows it to be partially opened, in order to improve ventilation. The canopy will remain open in this position. Flight characteristics will not be affected significantly.

The maximum demonstrated airspeed for emergency opening the front canopy in flight is 117 KIAS. Do not exceed 117 KIAS.

END OF CHECKLIST

3.12 OTHER EMERGENCIES

3.12.1 SUSPICION OF CARBON MONOXIDE CONTAMINATION IN THE CABIN

Carbon monoxide (CO) is a gas which is developed during the combustion process. It is poisonous and without smell. Increased concentration of carbon monoxide gas can be fatal. The occurrence of CO in the cabin is possible only due to a defect. If a smell similar to exhaust gases is noticed in the cabin, the following measures should be taken:

- 1. Cabin heat & Defrost OFF
- 2. Ventilation open
- 3. Emergency windows open
- 4. Forward canopy unlatch, push up and lock in
"cooling-gap" position

CAUTION

The maximum demonstrated airspeed for emergency opening the front canopy in flight is 117 KIAS. Do not exceed 117 KIAS.

END OF CHECKLIST

3.12.2 UNLOCKED DOORS

1. Airspeed reduce immediately
2. Canopy check visually if closed
3. Rear passenger door check visually if closed
4. Front baggage doors check visually if closed

Canopy Unlocked

5. Airspeed below 140 KIAS
6. Land at the next suitable airfield.

END OF CHECKLIST

Rear Passenger Door Unlocked

5. Airspeed below 140 KIAS
6. Land at the next suitable airfield.

WARNING

Do not try to lock the rear passenger door in flight. The safety latch may disengage and the door opens. Usually this results in a separation of the door from the airplane.

NOTE

If door has been lost the airplane can be safely flown to the next suitable airfield.

END OF CHECKLIST

Front Baggage Door Open

5. Airspeed reduce, so that door is in a stable position
6. Land at the next suitable airfield.

WARNING

Separation of the baggage door may damage the propeller and may lead to an engine failure.

END OF CHECKLIST

3.12.3 DEFECTIVE PROPELLER RPM REGULATING SYSTEM

CAUTION

The POWER lever should be moved slowly, in order to avoid over-speeding and excessively rapid RPM changes. The light wooden propeller blades produce more rapid RPM changes than metal blades.

WARNING

In case of a malfunction of the engine control unit it is possible that the propeller blades will remain in the position of highest pitch. In this case the reduced engine performance should be taken into consideration.

(a) Oscillating RPM

1. POWER setting change

If the problem does not clear:

2. Garmin G1000 check L/R ECU A/B FAIL caution

If L/R ECU A FAIL indicated:

3. VOTER switch ECU B

If L/R ECU B FAIL indicated:

3. VOTER switch ECU A

NOTE

If the problem does not clear itself, switch back to AUTO and land on the nearest suitable airfield.

CONTINUED

(b) Propeller Overspeed

NOTE

This procedure applies for continued propeller overspeed due to a malfunction in the propeller constant speed unit or a engine control unit malfunction.

- 1. POWER setting reduce as required

If the problem does not clear:

- 2. Garmin G1000 check L/R ECU A/B FAIL caution

If L/R ECU A FAIL indicated:

- 3. VOTER switch ECU B

If L/R ECU B FAIL indicated:

- 3. VOTER switch ECU A

CAUTION

If the problem does not clear itself, switch back to AUTO and land on the nearest suitable airfield. Prepare for engine malfunction according to 3.7.6 - ENGINE FAILURES IN FLIGHT.

CONTINUED

Doc. No. 7.01.16-E	Rev. 5	10-Jun-2021	Page 3 - 67
--------------------	--------	-------------	-------------

(c) Fixed RPM

1. POWER setting change

If the problem does not clear:

2. Garmin G1000 check L/R ECU A/B FAIL caution

If L/R ECU A FAIL indicated:

3. VOTER switch ECU B

If L/R ECU B FAIL indicated:

3. VOTER switch ECU A

NOTE

If the problem does not clear itself, switch back to AUTO and land on the nearest suitable airfield.

END OF CHECKLIST

3.12.4 UNINTENTIONAL FLIGHT INTO ICING

1. Leave the icing area (by changing altitude or turning back, in order to reach zones with a higher ambient temperature).
2. PITOT HEAT ON
3. Cabin heat & Defrost ON
4. POWER lever increase power, in order to prevent ice build up on the propeller blades, apply power changes periodically.
5. ALTERNATE AIR OPEN
6. Emergency windows open if required

CAUTION

Ice build-up increases the stalling speed.

7. ATC advise if an emergency is expected

END OF CHECKLIST

3.12.5 FUEL SUPPLY FAILURE

1. FUEL SELECTOR CROSSFEED /
affected engine

WARNING

In case of a fuel supply failure a fuel pump inspection is required prior to the next flight.

2. Fuel quantity monitor
3. Fuel pump of affected engine OFF

If fuel supply failure remains:

4. FUEL SELECTOR ON
5. Fuel pump of affected engine ON
6. Fuel quantity monitor

END OF CHECKLIST

3.12.6 RECOVERY FROM AN UNINTENTIONAL SPIN

CAUTION

Spin recovery has NOT been shown during certification as it is NOT required for this airplane category. The given recovery method is based on general experience!

CAUTION

Intentional spins are prohibited in this airplane. In the event a spin is encountered unintentionally, immediate recovery actions must be taken.

Single-engine stalling is not permitted.

CAUTION

Steps 1 to 4 must be carried out **immediately** and **simultaneously**.

- 1. POWER lever IDLE
- 2. Rudder full deflection against
direction of spin
- 3. Elevator (control stick) fully forward
- 4. Ailerons neutral
- 5. FLAPS UP

CONTINUED

When rotation has stopped:

6. Rudder neutral
7. Elevator (control stick) pull carefully
8. Return the airplane from a descending into a normal flight attitude. Do not exceed the 'never exceed speed', $v_{NE} = 188$ KIAS.

END OF CHECKLIST

3.12.7 EMERGENCY DESCENT

1. FLAPS UP
2. Gear DOWN
3. POWER lever IDLE
4. Airspeed as required

WARNING

Max. structural cruising speed $V_{NO} = 151$ KIAS.

Never exceed speed in smooth air $V_{NE} = 188$ KIAS.

END OF CHECKLIST

3.12.8 EMERGENCY EXIT

In case of a roll over of the airplane on ground, the rear side door can be used as exit. For this purpose unlock the front hinge of the rear side door. The function is displayed on a placard beside the hinge.

3.12.9 AUTOPILOT OR ELECTRIC TRIM MALFUNCTION / FAILURE

NOTE

An autopilot or electric trim malfunction may be recognized by an unexpected deviation from the desired flight path, abnormal flight control or trim wheel movement, or flight director commands which cause unexpected or contradictory information on the other cockpit displays. It may be accompanied by the aural autopilot disconnect tone, a red AFCS, red PTCH, red ROL, red YAW, red AP or yellow AP indication on the PFD, or a yellow CHECK ATTITUDE on the PFD. The autopilot and AHRS monitors normally detect failures and automatically disconnect the autopilot.

Failure of the electric pitch trim, indicated by a red boxed PTRM flashing on the PFD, may not cause the autopilot to disconnect. Be alert to possible autopilot out of trim conditions (see AUTOPILOT OUT OF TRIM procedure below), and expect residual control forces upon disconnect. The autopilot will not re-engage after disconnect with failed pitch trim. If AUTOPILOT OUT OF TRIM ELE indication is present, expect substantial elevator forces on autopilot disconnect.

NOTE

Accomplish items 1 and 2 simultaneously!

- 1. Airplane control stick grasp firmly and regain airplane control
- 2. AP DISC switch DEPRESS AND HOLD
- 3. Trim retrim airplane manually as required
- 4. AUTOPILOT circuit breaker pull
- 5. AP DISC switch RELEASE

NOTE

When the AUTOPILOT circuit breaker is pulled, the manual electric trim and autopilot autotrim systems will be disabled. The steps of disengaging the autopilot should be committed to memory and the pilot should be able to accomplish all steps without reference to a manual or other pilot documentation.

WARNING

Do not attempt to re-engage the autopilot following an autopilot, autotrim, or manual electric trim malfunction until the cause for the malfunction has been corrected.

END OF CHECKLIST

Intentionally left blank.

CHAPTER 4A

NORMAL OPERATING PROCEDURES

	Page
4A.1 INTRODUCTION	4A-3
4A.2 AIRSPEEDS FOR NORMAL OPERATING PROCEDURES	4A-4
4A.3 ADVISORY ALERTS ON THE G1000	4A-5
4A.3.1 ADVISORY/GENERAL	4A-5
4A.3.2 L/R GLOW ON	4A-5
4A.3.3 L/R AUXPUMP ON	4A-5
4A.3.4 PFD/MFD/GIA FAN FAIL	4A-5
4A.4 FLIGHT CHARACTERISTICS	4A-6
4A.5 DAILY CHECK	4A-6
4A.6 CHECKLISTS FOR NORMAL OPERATING PROCEDURES ...	4A-7
4A.6.1 PRE-FLIGHT INSPECTION	4A-7
4A.6.2 BEFORE STARTING ENGINE	4A-20
4A.6.3 STARTING ENGINE	4A-23
4A.6.4 BEFORE TAXIING	4A-25
4A.6.5 TAXIING	4A-27
4A.6.6 BEFORE TAKE-OFF	4A-28
4A.6.7 TAKE-OFF	4A-34
4A.6.8 CLIMB	4A-37
4A.6.9 CRUISE	4A-42
4A.6.10 DESCENT	4A-48
4A.6.11 APPROACH & LANDING	4A-53
4A.6.12 GO AROUND	4A-58
4A.6.13 AFTER LANDING	4A-60

4A.6.14 SHUT-DOWN	4A-61
4A.6.15 EXIT AIRPLANE	4A-62
4A.6.16 POST FLIGHT INSPECTION	4A-62
4A.6.17 PARKING	4A-62
4A.6.18 FLIGHT IN RAIN, SNOW OR VISIBLE MOISTURE ...	4A-63
.....	4A-63
4A.6.19 REFUELING	4A-64
4A.6.20 FLIGHT AT HIGH ALTITUDE	4A-67
4A.6.21 DEMONSTRATION OF ENGINE SHUTDOWN/RESTART	
.....	4A-67

4A.1 INTRODUCTION

Chapter 4A contains checklists and describes procedures for the normal operation of the airplane.

NOTE

Readability of the G1000 PFD and MFD displays may be degraded when wearing polarized sunglasses.

NOTE

Normal operating procedures for GFC 700 are described in the Garmin G1000 Cockpit Reference Guide, P/N 190-00963-() and the Garmin G1000 Pilot's Guide for the Diamond DA 42 NG, P/N 190-00962-().

If MÄM 42-978 is installed, normal operating procedures for GFC 700 are described in the Garmin G1000 NXi Cockpit Reference Guide, P/N 190-02238-() and the Garmin G1000 NXi Pilot's Guide for the Diamond DA 42 NG, P/N 190-02237-().

If MÄM 42-1072 is installed, normal operating procedures for GFC 700 are described in the Garmin G1000 NXi Cockpit Reference Guide, P/N 190-02527-() and the Garmin G1000 NXi Pilot's Guide for the Diamond DA 42 NG, P/N 190-02526-().

4A.2 AIRSPEEDS FOR NORMAL OPERATING PROCEDURES

	FLAPS	up to 1900 kg (4189 lb)	above 1900 kg (4189 lb)
Airspeed for rotation (take-off run, v_R)	UP	min. 76 KIAS	min. 76 KIAS
	APP	min. 71 KIAS	min. 74 KIAS
Airspeed for take-off climb (best rate-of-climb speed v_Y)	UP	min. 90 KIAS	min. 92 KIAS
Airspeed for take-off climb (best angle-of-climb speed v_X)	APP	min. 77 KIAS	min. 79 KIAS
Airspeed for best rate-of-climb (v_Y)	UP	90 KIAS	92 KIAS
	APP	85 KIAS	85 KIAS
Airspeed for cruise climb	UP	min. 90 KIAS	min. 92 KIAS
Reference landing approach speed	UP	86 KIAS	92 KIAS
	APP	min. 84 KIAS	min. 88 KIAS
Final approach speed	LDG	min. 84 KIAS	min. 86 KIAS
Minimum speed during go around	UP	min. 90 KIAS	min. 90 KIAS
Max. structural cruising speed Do not exceed this speed except in smooth air, and then only with caution.	UP	151 KIAS	151 KIAS

4A.3 ADVISORY ALERTS ON THE G1000

The G1000 provides the following advisory-alerts on the PFD in the alert area:

4A.3.1 ADVISORY/GENERAL

CHARACTERISTICS	White color coded text.
------------------------	-------------------------

4A.3.2 L/R GLOW ON

L/R GLOW ON	Left / Right engine glow plug active.
--------------------	---------------------------------------

4A.3.3 L/R AUXPUMP ON

L/R AUXPUMP ON	Fuel transfer from auxiliary to main tank is in progress (if installed).
-----------------------	--

4A.3.4 PFD/MFD/GIA FAN FAIL

PFD FAN FAIL	Cooling fan for the PFD is inoperative.
MFD FAN FAIL	Cooling fan for the MFD is inoperative.
GIA FAN FAIL	Cooling fan for the GIA is inoperative.

The flight may be continued, but maintenance action is required after landing.

Doc. No. 7.01.16-E	Rev. 5 10-Jun-2021	Page 4A - 5
--------------------	-------------------------	-------------

4A.4 FLIGHT CHARACTERISTICS

The DA 42 NG is to be flown with "the feet on the pedals", meaning that coordinated flight in all phases and configurations shall be supported by dedicated use of the rudder and ailerons together.

With the landing gear extended and at aft CG-locations, with flaps up and full power applied, the airplane will easily recover from sideslip if the trim is set to neutral (normal procedure), otherwise it may require corrective action with a moderate amount of rudder input.

4A.5 DAILY CHECK

Before the first flight of a day it must be ensured that the following checks are performed.

- * On-condition check of the canopy, the side door and the baggage compartment doors for cracks and major scratches.
- * On-condition check of the hinges for the canopy, the side door and the baggage compartment doors.
- * Visual inspection of the locking bolts for proper movement with no backlash.
- * Tire inflation pressure check (main wheels: 4.7 bar / 68 PSI, nose wheel: 6.0 bar / 87 PSI).
- * Visual inspection of both spinners and their attachment.

4A.6 CHECKLISTS FOR NORMAL OPERATING PROCEDURES

4A.6.1 PRE-FLIGHT INSPECTION

I. Cabin check

Preparation:

- a) Parking brake set ON
- b) MET, NAV, mass and balance flight planning completed
- c) Airplane documents complete and up to date
- d) Front canopy and rear door clean, undamaged, check locking mechanism function

- e) Baggage stowed and secure
- f) Foreign objects check
- g) Emergency axe (if OÄM 42-205 installed) stowed and secure
- h) Emergency egress hammer
(if OÄM 42-304 installed) stowed and secure
- i) Fire extinguisher check ready for use before every first flight of the week

Center console:

- a) FUEL SELECTOR check ON
- b) POWER lever check condition, freedom of movement and full travel/
adjust friction, set IDLE

Below instrument panel in front of left seat:

- a) ALTERNATE STATIC SOURCE check CLOSED
- b) Manual gear extension handle check pushed in

Below instrument panel in front of right seat:

- a) ALTERNATE AIR check CLOSED

On the instrument panel:

- a) ALTERNATOR check ON
- b) VOTER switch check AUTO
- c) PITOT HEAT check OFF
- d) ENGINE MASTER check both OFF
- e) START KEY check key is pulled out
- f) ELECT. MASTER check OFF
- g) AVIONIC MASTER check OFF
- h) GEAR SELECTOR check DOWN
- i) FLAP SELECTOR check UP
- j) Circuit breakers set in (if one has been pulled,
check reason)

- k) All electrical equipment OFF
- l) EMERGENCY switch check OFF and guarded
- m) ELT armed

CONTINUED

Check procedure:

- a) ELECT. MASTER ON

CAUTION

When switching the ELECT. MASTER ON, the electrically driven hydraulic gear pump may activate itself for 5 to 20 seconds in order to restore the system pressure. Should the pump continue to operate continuously or periodically, terminate flight. There is a malfunction in the landing gear system.

- b) Fuel quantity check indication, verify using alternate means (see Section 7.9.5)
- c) Position lights, strobe lights (ACL) check for correct function

CAUTION

Do not look directly into the anti collision lights.

- d) Landing / taxi light check for correct function
- e) Stall warning / stall heat / Pitot heat check

NOTE

Because the stall warning switch gets slightly warmer on ground, STAL HT FAIL may be indicated on the PFD.

CONTINUED

Doc. No. 7.01.16-E	Rev. 5 10-Jun-2021	Page 4A - 9
--------------------	-------------------------	-------------

- f) Gear warning /
fire detector TEST BUTTON PUSH, check aural alert/fire
detection warning and aural alert
and CHECK GEAR caution

CAUTION

If the aural alert or the warning on the PFD does not appear,
terminate flight. Unscheduled maintenance is necessary.

- g) Control stick pull fully aft/hold at backstop
- h) POWER lever set MAX
- i) Variable elevator backstop check function/control stick must
move slightly forward during
power lever forward movement

- j) POWER lever set IDLE
- k) Variable elevator backstop check function/control stick must
regain full movement during
power lever retraction

CAUTION

The proper function of the variable elevator backstop is
indispensable for the safety of flight, as the handling qualities
during power-on stalls are degraded significantly. For more
details see Chapter 7 - AIRPLANE DESCRIPTION AND
SYSTEMS.

If the variable elevator backstop does not function properly,
terminate flight preparation.

CONTINUED

Page 4A - 10	Rev. 5	10-Jun-2021	Doc. No. 7.01.16-E
--------------	--------	-------------	--------------------

- l) ELECT. MASTER OFF
- m) Flight controls check free and correct movement
up to full deflection

- n) Trims check free and correct movement
up to full deflection

END OF CHECKLIST

II. Walk-around check, visual inspection

CAUTION

A visual inspection means: examination for damage, cracks, delamination, excessive play, load transmission, correct attachment and general condition. In addition control surfaces should be checked for freedom of movement.

CAUTION

In low ambient temperatures the airplane must be completely cleared of ice, snow and similar accumulations. For approved de-icing fluids refer to Section 8.7 - GROUND DE-ICING.

CAUTION

Prior to flight, remove such items as control surfaces gust lock, Pitot cover, tow bar, etc.

1. *Left main landing gear:*

- a) Landing gear strut and lock visual inspection, sufficient height
(typical visible length of bare piston: at least 4 cm/1.6 in)
- b) Down and uplock switches (2 pieces) visual inspection
- c) Wear, tread depth of tire visual inspection
- d) Tire, wheel, brake visual inspection
- e) Brake line connection check for leaks
- f) Slip marks visual inspection
- g) Chocks remove
- h) Landing gear door visual inspection

CONTINUED

Page 4A - 12	Rev. 5	10-Jun-2021	Doc. No. 7.01.16-E
--------------	--------	-------------	--------------------

2. Left engine nacelle:

- a) 4 air inlets / 2 air outlets clear
- b) Engine oil level check dipstick (inspection hole in the upper cowling)
- c) Gearbox oil level check visually (inspection hole in the upper cowling)
- d) Cowling visual inspection
- e) Gascolator / air inlet drain off to check for water and sediment (drain until no water comes out)/clear
- f) Venting pipe check for blockage
- g) Exhaust visual inspection

WARNING

The exhaust can cause burns when hot.

- h) Propeller visual inspection

WARNING

Never move the propeller by hand while the ENGINE MASTER switch is ON! Also do not move the propeller by hand while the ENGINE MASTER is OFF immediately after operation (remaining pressure in the injection system rail). Serious personal injury may result.

- i) De-icing boots (if OÄM 42-053 carried out) . check for de-bonding

CONTINUED

Doc. No. 7.01.16-E	Rev. 5 10-Jun-2021	Page 4A - 13
--------------------	-------------------------	--------------

- j) Nacelle underside check for excessive contamination particularly by oil, fuel, and other fluids
- k) Auxiliary tank drain (if installed) drain off to check for water and sediment (drain until no water comes out) / visual inspection
- l) Auxiliary tank filler (if installed) visual inspection, tank filler closed

3. *Left wing:*

- a) Entire wing surface visual inspection
- b) Vortex generators undamaged, 4 pieces, clean
- c) Tank air outlet on lower surface visual inspection
- d) Tank drain/tank air inlet drain off to check for water and sediment (drain until no water comes out)/visual inspection
- e) Openings on lower surface check for foreign objects and for traces of fuel (if tank is full, fuel may spill over through the tank vent)
- f) Stall warn device visual inspection
- g) Tank filler visual inspection, check closed
- h) Pitot probe clean, orifices clear, cover removed, no deformation
- i) Wing tip visual inspection
- j) Static dischargers visual inspection
- k) Position light, strobe light (ACL) visual inspection

CONTINUED

- l) Tie-down check, clear
- m) Aileron and linkage cover visual inspection
- n) Aileron hinges and safety pin visual inspection
- o) Foreign objects in aileron paddle visual inspection
- p) Flap and linkage covers visual inspection
- q) Flap hinges and safety pin visual inspection
- r) Nacelle underside visual inspection
- s) Step visual inspection

4. *Fuselage, left side, underside:*

- a) Canopy, left side visual inspection
- b) Rear cabin door & window visual inspection
- c) Fuselage skin visual inspection
- d) Antennas visual inspection
- e) Fuselage check for contamination
(hydraulic fluid)
- f) Static source check for blockage

5. *Empennage:*

- a) Stabilizers and control surfaces,
elevator tips visual inspection
- b) Hinges visual inspection
- c) Elevator trim tab visual inspection, check safetying
- d) Rudder trim tab visual inspection, check safetying
- e) Tie-down check, clear
- f) Tail skid and lower fin visual inspection
- g) Static dischargers visual inspection
- h) Rudder gap seal visual inspection

CONTINUED

Doc. No. 7.01.16-E	Rev. 5 10-Jun-2021	Page 4A - 15
--------------------	-------------------------	--------------

6. *Fuselage, right side:*

- a) Fuselage skin visual inspection
- b) Rear window visual inspection
- c) Canopy, right side visual inspection
- d) Static source check for blockage

7. *Right Main Landing Gear:*

- a) Landing gear strut and lock visual inspection, sufficient height
(typical visible length of bare
piston: at least 4 cm/1.6 in)
- b) Down and uplock switches (2 pieces) visual inspection
- c) Wear, tread depth of tire visual inspection
- d) Tire, wheel, brake visual inspection
- e) Brake line connection check for leaks
- f) Slip marks visual inspection
- g) Chocks remove
- h) Landing gear door visual inspection

8. *Right wing:*

- a) Entire wing surface visual inspection
- b) Vortex generators undamaged, 4 pieces, clean
- c) Tank air outlet on lower surface visual inspection
- d) Tank drain/tank air inlet drain off to check for water and
sediment (drain until no water
comes out)/visual inspection

CONTINUED

- e) Openings on lower surface check for foreign objects and for traces of fuel (if tank is full, fuel may spill over through the tank vent)
- f) Tank filler visual inspection, check closed
- g) Wing tip visual inspection
- h) Static dischargers visual inspection
- i) Position light, strobe light (ACL) visual inspection
- j) Tie-down check, clear
- k) Aileron and linkage cover visual inspection
- l) Aileron hinges and safety pin visual inspection
- m) Foreign objects in aileron paddle visual inspection
- n) Flap and linkage covers visual inspection
- o) Flap hinges and safety pin visual inspection
- p) Nacelle underside visual inspection
- q) Step visual inspection
- r) Cabin vent air inlet check clear

if OÄM 42-279 is installed:

- Verify the outside air temperature, determine the recommended use of the winter kit - ventilation.
- s) Winter kit - ventilation check for improper mounting or obvious damage

CONTINUED

Doc. No. 7.01.16-E	Rev. 5 10-Jun-2021	Page 4A - 17
--------------------	-------------------------	--------------

9. *Right engine nacelle:*

- a) 4 air inlets / 2 air outlets clear
- b) Engine oil level check dipstick (inspection hole in the upper cowling)
- c) Gearbox oil level check visually (inspection hole in the upper cowling)
- d) Cowling visual inspection
- e) Gascolator / air inlet drain off to check for water and sediment (drain until no water comes out)/clear
- f) Venting pipe check for blockage
- g) Exhaust visual inspection

WARNING

The exhaust can cause burns when hot.

- h) Propeller visual inspection

WARNING

Never move the propeller by hand while the ENGINE MASTER switch is ON! Also do not move the propeller by hand while the ENGINE MASTER is OFF immediately after operation (remaining pressure in the injection system rail). Serious personal injury may result.

- i) De-icing boots (if OÄM 42-053 carried out) . . check for de-bonding

CONTINUED

Page 4A - 18	Rev. 5	10-Jun-2021	Doc. No. 7.01.16-E
--------------	--------	-------------	--------------------

- j) Nacelle underside check for excessive contamination particularly by oil, fuel, and other fluids
- k) Auxiliary tank drain (if installed) drain off to check for water and sediment (drain until no water comes out)/visual inspection
- l) Auxiliary tank filler (if installed) visual inspection, tank filler closed

10. Front fuselage and nose landing gear:

- a) Left and right front baggage door visual inspection, closed and locked
- b) Nose landing gear strut visual inspection, sufficient height (typical visible length of bare piston: at least 15 cm/5.9 in)
- c) Down & uplock switches visual inspection
- d) Wear, tread depth of tire check
- e) Slip marks visual inspection
- f) Gear door and linkage visual inspection
- g) Nose cone surface (if OÄM 42-119 or OÄM 42-273 is installed) visual inspection
- h) Attachment screws (if OÄM 42-119 or OÄM 42-273 is installed) visual inspection
- i) Lightning protection strips (4 pieces, if OÄM 42-119 or OÄM 42-273 is installed) visual inspection
- j) Chocks remove
- k) OAT sensor check
- l) EPU connector check
- m) Tow bar remove

END OF CHECKLIST

Doc. No. 7.01.16-E	Rev. 5	10-Jun-2021	Page 4A - 19
--------------------	--------	-------------	--------------

4A.6.2 BEFORE STARTING ENGINE

1. Preflight inspection complete
2. Passengers instructed

NOTE

Ensure all the passengers have been fully briefed on the use of the seat belts, doors and emergency exits and the ban on smoking.

3. Rear door closed and locked

CAUTION

When operating the canopy, pilots/operators must ensure that there are no obstructions between the canopy and the mating frame, for example seat belts, clothing, etc. When operating the locking handle do NOT apply undue force.

A slight downward pressure on the canopy may be required to ease the handle operation.

4. Front canopy Position 1 or 2 (“cooling gap”)

CAUTION

For take-off the adjustable backrests (if installed) must be fixed in the upright position.

CONTINUED

Page 4A - 20	Rev. 5	10-Jun-2021	Doc. No. 7.01.16-E
--------------	--------	-------------	--------------------

NOTE

The pilot must ensure that a passenger sitting on a front seat is instructed in the operation of the adjustable backrest (if installed).

- 5. Adjustable backrests (if installed) adjust to the upright position described by a placard on the roll-over bar and verify proper fixation
- 6. Rudder pedals adjusted; if manual pedal adjustment is installed: verify proper locking
- 7. Safety harnesses all on and fastened
- 8. POWER lever check IDLE
- 9. Parking brake set
- 10. AVIONIC MASTER check OFF
- 11. GEAR selector check DOWN
- 12. VOTER switch check AUTO
- 13. ALTERNATORS check ON
- 14. Fuel pump LH/RH check OFF
- 15. ELECT. MASTER ON

CAUTION

When switching the ELECT. MASTER ON, the electrically driven hydraulic gear pump may activate itself for 5 to 20 seconds in order to restore the system pressure. Should the pump continue to operate continuously or periodically, terminate flight preparation. There is a malfunction in the landing gear system.

CONTINUED

Doc. No. 7.01.16-E	Rev. 5 10-Jun-2021	Page 4A - 21
--------------------	-------------------------	--------------

16. G1000 wait until power-up completed.
Press ENT on MFD to
acknowledge.

NOTE

The engine instruments are only available on the MFD after
item 16 has been completed.

17. Fuel temperature check

END OF CHECKLIST

4A.6.3 STARTING ENGINE

NOTE

At ambient temperatures below -22°C the engine may not start at the first attempt. In this case wait 60 seconds between the start attempts.

- 1. Strobe lights (ACL) ON
- 2. ENGINE MASTER ON (L)
- 3. Annunciations check "L ENGINE GLOW" ON

NOTE

"L ENGINE GLOW" is indicated only when the engine is cold.

- 4. Annunciations / Engine / System Page check OK/normal range

WARNING

Before starting the engine the pilot must ensure that the propeller area is free, and no persons can be endangered.

After the L ENGINE GLOW indication is extinguished:

- 5. START KEY START L as required / release when engine has started.

CONTINUED

Doc. No. 7.01.16-E	Rev. 5 10-Jun-2021	Page 4A - 23
--------------------	-------------------------	--------------

CAUTION

Do not overheat the starter motor. Do not operate the starter motor for more than 10 seconds.

At ambient temperatures below -22°C it is possible that the engine will not start at the first attempt. In this case wait 60 seconds between the start attempts.

If the "L STARTER" annunciation comes on after the engine has started and the START KEY has been released, set the ENGINE MASTER to OFF and investigate the problem.

- 6. Annunciations / Engine / System Page check OK/normal range
- 7. Annunciations / Starter check OFF
- 8. Annunciations / Oil pressure check OK

WARNING

If the oil pressure has not moved from the red range within 3 seconds after starting, set the ENGINE MASTER switch to OFF and investigate problem.

- 9. Circuit breakers check all in/as required
- 10. Idle RPM check, 710 ±30 RPM

Repeat with opposite engine.

END OF CHECKLIST

4A.6.4 BEFORE TAXIING

- 1. AVIONIC MASTER ON
- 2. Power lever as required, max. 50% if engine temperature below green range
- 3. Electrical equipment ON as required
- 4. Flight instruments and avionics set as required
- 5. Flood light ON, test function, as required
- 6. Pitot and stall warn heating ON, wait up to 20 seconds, check annunciation

NOTE

PITOT HT OFF and STAL HT OFF will extinguish, STAL HT FAIL is indicated on the PFD (this may take up to 20 seconds).

- 7. Pitot and stall warn heating OFF
- 8. Strobe lights (ACLs) check ON
- 9. Position lights, landing and taxi lights as required

CAUTION

When taxiing at close range to other airplane, or during night flight in clouds, fog or haze, the strobe lights should be switched OFF. The position lights must always be switched ON during night flight.

- 10. Primary flight display (PFD) NO AUTOPILOT ANNUNCIATIONS

11. Autopilot disconnect tone NOTE

NOTE

The AFCS system automatically conducts a preflight self-test upon initial power application. The preflight test is indicated by a white boxed PFT on the PFD. Upon successful completion of the preflight test, the PFT is removed, the red AFCS annunciation is removed, and the autopilot disconnect tone sounds. If AFCS annunciation remains on or a failure of the preflight test is indicated terminate flight preparation and investigate the problem.

12. MANUAL ELECTRIC TRIM - TEST as follows:

Press the AP DISC button down and hold while commanding trim.

Manual electric trim should not operate either nose up or nose down.

13. AUTOPILOT engage by pressing AP button

14. AP DISC switch press. verify that the autopilot disconnects

15. TRIM set to take-off position manually

END OF CHECKLIST

4A.6.5 TAXIING

- 1. Parking brake release
- 2. Brakes test on moving off
- 3. Nose wheel steering check for proper function
- 4. Flight instrumentation and avionics check for correct indications
- 5. Fuel pumps LH/RH check OFF
- 6. FUEL SELECTOR CROSSFEED (LH/RH)

CAUTION

The fuel crossfeed function can be tested simultaneously with both engines. Proper function can be tested by running the engines for approx. 30 seconds with CROSSFEED selected. The operation of both engines with both FUEL SELECTORS in CROSSFEED position, other than for this test, is prohibited.

- 7. FUEL SELECTOR ON (LH/RH)

CAUTION

When taxiing on a poor surface select the lowest possible RPM to avoid damage to the propeller from stones or similar items.

END OF CHECKLIST

4A.6.6 BEFORE TAKE-OFF

1. Position airplane into wind if possible.
2. Parking brake set

CAUTION

For take-off the adjustable backrests (if installed) must be fixed in the upright position.

3. Adjustable backrests (if installed) verify upright position
and proper fixation
4. Safety harnesses on and fastened
5. Rear door check closed and locked

CAUTION

When operating the canopy, pilots/operators must ensure that there are no obstructions between the canopy and the mating frame, for example seat belts, clothing, etc. When operating the locking handle do NOT apply undue force.

A slight downward pressure on the canopy may be required to ease the handle operation.

6. Front canopy closed and locked
7. Front baggage doors closed (visual check)
8. Door warning (DOOR) check no indication

CONTINUED

- 9. Annunciations / Engine / System Page check OK / normal range
(except oil pressure may be in the yellow range with a warm engine and power lever set to IDLE)
- 10. Circuit breakers check pressed in
- 11. Longitudinal trim set T/O

WARNING

Take-off with CROSSFEED selected is prohibited.

- 12. FUEL SELECTOR check ON (LH/RH)
- 13. Directional trim neutral
- 14. FLAPS check function & indicator /
set UP
- 15. Flight controls unrestricted free movement,
correct sense
- 16. PITOT HEAT ON, if in rain, snow or visible
moisture and if OAT is below 5°C
- 17. Landing light ON, if required

CONTINUED

ECU / fuel pumps test sequence:

CAUTION

If the L/R ECU A/B FAIL indicators do not illuminate during the test sequence there is a malfunction in the engine control system. Terminate flight preparation.

The whole test procedure must be completed without any error (L/R ECU A/B FAIL extinguished after test completion). In case the test procedure aborts with an error indication (one or both ECU A/B FAIL indicators remain ON) terminate flight preparation, even if the engine seems to run smoothly after the test procedure.

NOTE

The following test sequence can be executed for both engines simultaneously, or in sequence.

The engine/gearbox oil temperatures have to be in the green range before starting the test sequence. Efficient engine warm up may require higher power settings (max. 50% engine power).

During the test sequence the engines will produce thrust therefore the parking brake must be set.

Releasing the ECU TEST BUTTON or manipulating the power lever before the test sequence is completed will abort the test sequence.

During the following ECU and fuel pump test, a shake of the engine might occur.

CONTINUED

- 1. Power lever IDLE
- 2. Propeller RPM check below 1000 rpm
- 3. Fuel pumps check OFF
- 4. VOTER switch check AUTO
- 5. Engine/gearbox oil temperature check in the green range
- 6. Parking brake check set
- 7. ECU TEST button press and hold

Annunciations in the following sequence:

- ECU A/B FAIL lights ON
- Propeller RPM increase above 1800 rpm
- Propeller RPM decrease
- Propeller RPM increase above 1800 rpm
- Propeller RPM decrease to idle

At this point, the test transfers from one ECU channel to the other.

- Propeller RPM increase above 1800 rpm
- Propeller RPM decrease
- Propeller RPM increase above 1800 rpm
- Propeller RPM decrease to idle

At this point, control of the engine is returned to the initially active ECU channel. A slight shake of the engine might occur.

- ECU A/B FAIL lights both OFF

Test sequence completed.

CONTINUED

8. ECU TEST button release

NOTE

By switching between ECU A and B the two independent electrical fuel pumps are switched over as well.

- 9. VOTER switch ECU A
- 10. Engine check running without a change
(shake may occur)
- 11. VOTER switch AUTO
- 12. Engine check running without a change
(shake may occur)
- 13. VOTER switch ECU B
- 14. Engine check running without a change
(shake may occur)
- 15. VOTER switch AUTO

CAUTION

Running the engine with the VOTER switch on ECU A or ECU B, other than for this test or in an emergency is prohibited. The engine control system redundancy is only given with the VOTER switch set to AUTO.

16. Parking brake release

CONTINUED

Available power check:

1. POWER lever MAX for 10 seconds
2. Annunciators check OK / normal range
3. Instruments check within normal range
4. RPM stabilizes at 2250 to 2300 RPM
5. LOAD indication stabilizes at 89% to 100%

CAUTION

The load indications in the table below are minimum values to be indicated with the airplane stationary in no wind conditions. If the engine does not stabilize at the target RPM and the required load indication, terminate flight preparation.

Altitude [ft]	OAT								
	-35°C -31°F	-20°C -4°F	-10°C 14°F	0°C 32°F	10°C 50°F	20°C 68°F	30°C 86°F	40°C 104°F	50°C 122°F
0	99%					97%	96%	93%	91%
2000						97%	96%	93%	/
4000						97%	96%	93%	/
6000						97%	96%	93%	/
8000			98%	98%	98%	96%	95%	92%	/
10000	98%	97%	97%	95%	94%	92%	89%	/	/

6. POWER lever IDLE
7. Engine instruments check in green range

NOTE

With the power lever in IDLE the oil pressure may be in the low yellow range. This is acceptable to continue flight.

8. Fuel pumps LH/RH ON

END OF CHECKLIST

4A.6.7 TAKE-OFF

a) Standard Procedure (Take-off with Flaps UP)

1. Transponder as required
2. POWER lever MAX

NOTE

The proper and symmetric performance of the engines at MAX should be checked early during the take-off run, so that the take-off can be aborted if necessary.

3. Elevator neutral
4. Rudder maintain direction

NOTE

In strong crosswinds steering can be augmented by use of the toe brakes. It should be noted, however, that this method increases the take-off roll, and should not generally be used.

5. Nose wheel lift-off: v_R min. 76 KIAS
6. Airspeed for initial climb:
Up to 1900 kg (4189 lb) min. 83 KIAS, recommended
90 KIAS (v_y) when clear of
obstacles
Above 1900 kg (4189 lb) min. 83 KIAS, recommended
92 KIAS (v_y) when clear of
obstacles

CONTINUED

When safe climb is established:

- 7. LANDING GEAR apply brakes; UP,
check unsafe light off

NOTE

To avoid damage and excessive wear of the main landing gear wheels, firmly apply brakes before selecting gear up.

- 8. Fuel pumps LH/RH OFF
- 9. ALTERNATE AIR OPEN in rain, snow or visible moisture

| END OF CHECKLIST

b) Short Field Procedure (Take-off with Flaps APP)

- 1. Transponder as required
- 2. POWER lever MAX

NOTE

The proper and symmetric performance of the engines at MAX should be checked early during the take-off run, so that the take-off can be aborted if necessary.

- 3. Elevator neutral
- 4. Rudder maintain direction

CONTINUED

Doc. No. 7.01.16-E	Rev. 5 10-Jun-2021	Page 4A - 35
--------------------	-------------------------	--------------

NOTE

In strong crosswinds steering can be augmented by use of the toe brakes. It should be noted, however, that this method increases the take-off roll, and should not generally be used.

5. Nose wheel lift-off:

- Up to 1900 kg (4189 lb) v_R min. 71 KIAS
- Above 1900 kg (4189 lb) v_R min. 74 KIAS

6. Airspeed for initial climb:

- Up to 1900 kg (4189 lb) min. 77 KIAS, recommended
85 KIAS (v_y) when clear of
obstacles
- Above 1900 kg (4189 lb) min. 79 KIAS, recommended
85 KIAS (v_y) when clear of
obstacles

When safe climb is established:

- 7. LANDING GEAR apply brakes; UP,
check unsafe light off

NOTE

To avoid damage and excessive wear of the main landing gear wheels, firmly apply brakes before selecting gear up.

- 8. Fuel pumps LH/RH OFF
- 9. ALTERNATE AIR OPEN in rain, snow or visible
moisture

END OF CHECKLIST

4A.6.8 CLIMB

Initial Climb Check

- 1. Landing light OFF / as required
- 2. Landing gear check UP
- 3. FLAPS check UP
- 4. Airspeed:
 - Up to 1900 kg (4189 lb) 90 KIAS (best rate-of-climb)
90 KIAS / as required for en route
(cruise) climb
 - Above 1900 kg (4189 lb) 92 KIAS (best rate-of-climb)
92 KIAS / as required for en route
(cruise) climb
- 5. POWER lever 92%
- 6. Trim as required (ball centered)
- 7. Annunciations / Engine / System Page monitor

CAUTION

If the oil temperature and/or coolant temperature reaches the yellow range during climb, flight should be continued with the airspeed increased by 10 kts and power reduced by 10 % (reduced climb rate) for better engine cooling.

NOTE

Operating in the gearbox temperature cautionary range is permitted. However, prolonged operation is not recommended.

END OF CHECKLIST

Doc. No. 7.01.16-E	Rev. 5 10-Jun-2021	Page 4A - 37
--------------------	-------------------------	--------------

GFC 700 Operation During Climb

NOTE

The NOSE UP and NOSE DN buttons on the mode controller on the MFD are referenced to airplane movement. The NOSE UP button will increase the reference pitch attitude, increase the reference vertical speed and decrease the reference airspeed. Likewise, the NOSE DN button will decrease the reference pitch attitude, decrease the reference vertical speed, and increase the reference airspeed.

a) Vertical Speed (VS)

1. Altitude preselect set to desired altitude
2. Mode controller select VS on mode controller
3. Vertical speed reference adjust using NOSE UP
and NOSE DN buttons
4. White ALT (altitude preselect armed) note on PFD
5. Green ALT verify upon altitude capture

NOTE

If the altitude preselect is not changed before selecting VS, the autopilot may re-capture the current altitude immediately after entering VS mode. Always ensure that the altitude preselect is adjusted prior to selecting VS.

The vertical speed mode is limited to 1500 ft/min climb and 3000 ft/minute descent. Use engine power to maintain appropriate airplane speed. If the CWS switch is used while in VS mode, the VS reference will change to the vertical speed when the CWS switch is released.

END OF CHECKLIST

Page 4A - 38	Rev. 5	10-Jun-2021	Doc. No. 7.01.16-E
--------------	--------	-------------	--------------------

b) Flight Level Change (FLC)

1. Altitude preselect set to desired altitude
2. Mode controller select FLC on mode controller
3. Airspeed speed reference adjust using NOSE UP
and NOSE DN buttons
4. White ALT (altitude preselect armed) note on PFD
5. Green ALT verify upon altitude capture

NOTE

If the altitude preselect is not changed before selecting FLC, the autopilot may re-capture the current altitude immediately after entering FLC mode. Always ensure that the altitude preselect is adjusted prior to selecting FLC.

If the airspeed reference cannot be maintained without deviating away from the selected altitude, the system will maintain level flight until the power or reference is changed to allow climbing or descending towards the selected altitude.

The FLC mode is limited to airspeeds between 90 KIAS and 180 KIAS. Use engine power to maintain appropriate vertical speed. If the CWS switch is used while in FLC mode, the airspeed reference will change to the airspeed when the CWS switch is released.

END OF CHECKLIST

c) To Capture a Selected Altitude

1. Altimeter setting adjust to appropriate value
2. Altitude preselect set to desired altitude
3. Vertical mode and reference select on mode controller
4. White ALT (altitude preselect armed) note on PFD
5. Green ALT verify upon altitude capture

NOTE

In ALT mode, the autopilot will maintain the reference altitude shown in the autopilot window of the PFD regardless of the altitude in the altitude preselect window or the altimeter's barometric pressure setting. If the altimeter setting is changed, the autopilot will climb or descend to maintain the reference altitude.

END OF CHECKLIST

d) Navigation Capture and Track:

- 1. Navigation source select VOR or GPS using
CDI button on PFD
- 2. Course bearing pointer set using course knob
(VOR only)
- 3. Intercept heading establish in HDG or ROL mode
(if required)
- 4. Mode controller select NAV on mode controller
- 5. Green or white VOR or GPS annunciation . . note on PFD
- 6. Vertical mode and reference select on mode controller

NOTE

If the Course Deviation Indicator (CDI) is greater than one dot from center, the autopilot will arm the NAV mode and indicate VOR or GPS in white on the PFD. The pilot must ensure that the current heading will result in a capture of the selected course. If the CDI is one dot or less from center, the autopilot will enter the capture mode when the NAV button is pressed and annunciate VOR or GPS in green on the PFD.

END OF CHECKLIST

4A.6.9 CRUISE

1. POWER lever up to 92%

NOTE

The engine manufacturer recommends a cruise power setting of 75 %.

2. Trim as required
3. Annunciations / Engine / System Page monitor

Use of the Auxiliary Fuel Tanks (if installed)

CAUTION

When operating the AUX PUMP LH / RH switch, make sure not to exceed the fuel imbalance limitations given in Section 2.14 - FUEL.

To avoid additional imbalance in the auxiliary tanks both AUX PUMP switches must be operated simultaneously.

1. Transfer the first half of the auxiliary fuel:

As soon as the fuel quantity in each main fuel tank is 17 US gal or less, set both AUX PUMP switches to ON until the main tanks are full again.

Monitor the fuel quantity indicator to verify that fuel is properly transferred to both main fuel tanks (approx. 1 US gal per minute). If the fuel quantity in a main tank does not increase during fuel transfer, proceed according to Section 4B.12 - L/R FUEL TRANSFER FAIL.

CONTINUED

Page 4A - 42	Rev. 5	10-Jun-2021	Doc. No. 7.01.16-E
--------------	--------	-------------	--------------------

2. *Transfer the second half of the auxiliary fuel:*

Repeat the procedure described above.

NOTE

Transfer the fuel from the auxiliary tanks to the main tanks as soon as possible. The fuel in the auxiliary tanks must be transferred to the main tanks to become available for the current flight mission.

END OF CHECKLIST

GFC 700 Operation During Cruise

NOTE

The NOSE UP and NOSE DN buttons on the mode controller on the MFD are referenced to airplane movement. The NOSE UP button will increase the reference pitch attitude, increase the reference vertical speed and decrease the reference airspeed. Likewise, the NOSE DN button will decrease the reference pitch attitude, decrease the reference vertical speed, and increase the reference airspeed.

a) Vertical Speed (VS)

- 1. Altitude preselect set to desired altitude
- 2. Mode controller select VS on mode controller
- 3. Vertical speed reference adjust using NOSE UP
and NOSE DN buttons
- 4. White ALT (altitude preselect armed) note on PFD
- 5. Green ALT verify upon altitude capture

CONTINUED

Doc. No. 7.01.16-E	Rev. 5 10-Jun-2021	Page 4A - 43
--------------------	-------------------------	--------------

NOTE

If the altitude preselect is not changed before selecting VS, the autopilot may re-capture the current altitude immediately after entering VS mode. Always ensure that the altitude preselect is adjusted prior to selecting VS.

The vertical speed mode is limited to 1500 ft/min climb and 3000 ft/min descent. Use engine power to maintain appropriate airplane speed. If the CWS switch is used while in VS mode, the VS reference will change to the vertical speed when the CWS switch is released.

END OF CHECKLIST

b) Flight Level Change (FLC)

1. Altitude preselect set to desired altitude
2. Mode controller select FLC on mode controller
3. Airspeed speed reference adjust using NOSE UP
and NOSE DN buttons
4. White ALT (altitude preselect armed) note on PFD
5. Green ALT verify upon altitude capture

CONTINUED

NOTE

If the altitude preselect is not changed before selecting FLC, the autopilot may re-capture the current altitude immediately after entering FLC mode. Always ensure that the altitude preselect is adjusted prior to selecting FLC.

If the airspeed reference cannot be maintained without deviating away from the selected altitude, the system will maintain level flight until the power or reference is changed to allow climbing or descending towards the selected altitude.

The FLC mode is limited to airspeeds between 90 KIAS and 180 KIAS. Use engine power to maintain appropriate vertical speed. If the CWS switch is used while in FLC mode, the airspeed reference will change to the airspeed when the CWS switch is released.

END OF CHECKLIST

c) To Capture a Selected Altitude

- 1. Altimeter setting adjust to appropriate value
- 2. Altitude preselect set to desired altitude
- 3. Vertical mode and reference select on mode controller
- 4. White ALT (altitude preselect armed) note on PFD
- 5. Green ALT verify upon altitude capture

CONTINUED

Doc. No. 7.01.16-E	Rev. 5 10-Jun-2021	Page 4A - 45
--------------------	-------------------------	--------------

NOTE

In ALT mode, the autopilot will maintain the reference altitude shown in the autopilot window of the PFD regardless of the altitude in the altitude preselect window or the altimeter's barometric pressure setting. If the altimeter setting is changed, the autopilot will climb or descend to maintain the reference altitude.

END OF CHECKLIST

d) Altitude Hold

To maintain a selected altitude:

1. Altimeter setting adjust to appropriate value
2. Reaching desired altitude select ALT on mode controller
3. Green ALT verify on PFD

END OF CHECKLIST

e) Navigation Capture and Track:

- 1. Navigation source select VOR or GPS using
CDI button on PFD
- 2. Course bearing pointer set using course knob
(VOR only)
- 3. Intercept heading establish in HDG or ROL
mode (if required)
- 4. Mode controller select NAV on mode controller
- 5. Green or white VOR or GPS annunciation . . note on PFD
- 6. Vertical mode and reference select on mode controller

NOTE

If the Course Deviation Indicator (CDI) is greater than one dot from center, the autopilot will arm the NAV mode and indicate VOR or GPS in white on the PFD. The pilot must ensure that the current heading will result in a capture of the selected course. If the CDI is one dot or less from center, the autopilot will enter the capture mode when the NAV button is pressed and annunciate VOR or GPS in green on the PFD.

END OF CHECKLIST

4A.6.10 DESCENT

1. POWER lever as required
2. Airspeed as required
3. Trim as required
4. PEDs OFF, if low visibility approach
5. Annunciations/Engine/System Page monitor

NOTE

Definition of the switched-off status for PEDs:

Many PEDs are not completely disconnected from the internal power source when switched off. The switching function may leave some remaining functionality e.g. data storage, timer, clock, etc.

These devices can be considered switched off when in the deactivated status. The same applies to devices having no transmitting capability and are operated by coin cells without further deactivation capability, e.g. wrist watches.

END OF CHECKLIST

GFC 700 Operation During Descent

NOTE

The NOSE UP and NOSE DN buttons on the mode controller on the MFD are referenced to airplane movement. The NOSE UP button will increase the reference pitch attitude, increase the reference vertical speed and decrease the reference airspeed. Likewise, the NOSE DN button will decrease the reference pitch attitude, decrease the reference vertical speed, and increase the reference airspeed.

a) Vertical Speed (VS)

1. Altitude preselect set to desired altitude
2. Mode controller select VS on mode controller
3. Vertical speed reference adjust using NOSE UP and NOSE DN buttons
4. White ALT (altitude preselect armed) note on PFD
5. Green ALT verify upon altitude capture

NOTE

If the altitude preselect is not changed before selecting VS, the autopilot may re-capture the current altitude immediately after entering VS mode. Always ensure that the altitude preselect is adjusted prior to selecting VS.

The vertical speed mode is limited to 1500 ft/min climb and 3000 ft/minute descent. Use engine power to maintain appropriate airplane speed. If the CWS switch is used while in VS mode, the VS reference will change to the vertical speed when the CWS switch is released.

END OF CHECKLIST

Doc. No. 7.01.16-E	Rev. 5 10-Jun-2021	Page 4A - 49
--------------------	-------------------------	--------------

b) Flight Level Change (FLC)

1. Altitude preselect set to desired altitude
2. Mode controller select FLC on mode controller
3. Airspeed speed reference adjust using NOSE UP
and NOSE DN buttons
4. White ALT (altitude preselect armed) note on PFD
5. Green ALT verify upon altitude capture

NOTE

If the altitude preselect is not changed before selecting FLC, the autopilot may re-capture the current altitude immediately after entering FLC mode. Always ensure that the altitude preselect is adjusted prior to selecting FLC.

If the airspeed reference cannot be maintained without deviating away from the selected altitude, the system will maintain level flight until the power or reference is changed to allow climbing or descending towards the selected altitude.

The FLC mode is limited to airspeeds between 90 KIAS and 180 KIAS. Use engine power to maintain appropriate vertical speed. If the CWS switch is used while in FLC mode, the airspeed reference will change to the airspeed when the CWS switch is released.

END OF CHECKLIST

c) To Capture a Selected Altitude

1. Altimeter setting adjust to appropriate value
2. Altitude preselect set to desired altitude
3. Vertical mode and reference select on mode controller
4. White ALT (altitude preselect armed) note on PFD
5. Green ALT verify upon altitude capture

NOTE

In ALT mode, the autopilot will maintain the reference altitude shown in the autopilot window of the PFD regardless of the altitude in the altitude preselect window or the altimeter's barometric pressure setting. If the altimeter setting is changed, the autopilot will climb or descend to maintain the reference altitude.

END OF CHECKLIST

d) Navigation Capture and Track:

1. Navigation source select VOR or GPS using
CDI button on PFD
2. Course bearing pointer set using course knob
(VOR only)
3. Intercept heading establish in HDG or ROL
mode (if required)
4. Mode controller select NAV on mode controller
5. Green or white VOR or GPS annunciation .. note on PFD
6. Vertical mode and reference select on mode controller

NOTE

If the Course Deviation Indicator (CDI) is greater than one dot from center, the autopilot will arm the NAV mode and indicate VOR or GPS in white on the PFD. The pilot must ensure that the current heading will result in a capture of the selected course. If the CDI is one dot or less from center, the autopilot will enter the capture mode when the NAV button is pressed and annunciate VOR or GPS in green on the PFD.

END OF CHECKLIST

4A.6.11 APPROACH & LANDING

Approach:

CAUTION

For landing the adjustable backrests (if installed) must be fixed in the upright position.

1. Adjustable backrests (if installed) adjust to the upright position described by a placard on the roll-over bar and verify proper fixation

2. Safety harnesses check fastened and tightened
3. Yaw damper check OFF
4. Controls no interference by foreign objects
5. Landing light as required
6. Gear warning horn check function
7. FUEL SELECTOR check ON
8. Fuel pumps LH/RH ON
9. LANDING GEAR DOWN, check 3 green
10. Parking brake check released
11. Trim as required, directional trim neutral

CONTINUED

Before landing:

12. Airspeed:

Up to 1900 kg (4189 lb) min. 86 KIAS with FLAPS UP
min. 84 KIAS with FLAPS APP

Above 1900 kg (4189 lb) min. 92 KIAS with FLAPS UP
min. 88 KIAS with FLAPS APP

13. FLAPS as required

14. POWER lever as required

15. Trim as required, directional trim
neutral

16. Final approach speed:

Up to 1900 kg (4189 lb) min. 84 KIAS with FLAPS LDG

Above 1900 kg (4189 lb) min. 86 KIAS with FLAPS LDG

NOTE

Higher approach speeds result in a significantly longer landing distance during flare.

CAUTION

In conditions such as (e.g.) strong wind, danger of wind shear or turbulence a higher approach speed should be selected.

END OF CHECKLIST

GFC 700 Operation During Approach and Landing

a) VOR

1. Navigation source select VOR using CDI
button on PFD
2. Course bearing pointer set using course knob
3. Intercept heading establish in HDG or ROL
mode (if required)
4. Mode controller select APR on mode controller
5. Green or white VAPP annunciation note on PFD
6. Vertical mode and reference select on mode controller

NOTE

If the Course Deviation Indicator (CDI) is greater than one dot from center, the autopilot will arm the VAPP mode and indicate VAPP in white on the PFD. The pilot must ensure that the current heading will result in a capture of the selected course. If the CDI is one dot or less from center, the autopilot will enter the capture mode when the VAPP button is pressed and annunciate VAPP in green on the PFD.

END OF CHECKLIST

b) ILS

1. Navigation source select LOC using CDI
button on PFD
2. Course bearing pointer set using course knob
3. Intercept heading establish in HDG or ROL
mode (if required)
4. Mode controller select APR on mode controller
5. Green or white LOC and GS annunciation . . note on PFD
6. Vertical mode and reference select on mode controller

NOTE

When the selected navigation source is a valid ILS, glideslope coupling is automatically armed when tracking the localizer. The glideslope cannot be captured until the localizer is captured. The autopilot can capture the glideslope from above or below the glideslope.

END OF CHECKLIST

c) GPS

- 1. Navigation source select GPS using CDI
button on PFD
- 2. Approach load in FMS and ACTIVATE
- 3. Intercept heading establish in HDG or ROL
mode (if required)
- 4. Mode controller select APR on mode controller
- 5. Green or white GPS annunciation note on PFD
- 6. Vertical mode and reference select on mode controller

END OF CHECKLIST

d) Back Course (BC)

- 1. Navigation source select LOC using CDI
button on PFD
- 2. Course bearing pointer set to ILS front Course
using course knob
- 3. Intercept heading establish in HDG or ROL
mode (if required)
- 4. Mode controller select NAV on mode controller
- 5. Green or white BC annunciation note on PFD

CONTINUED

Doc. No. 7.01.16-E	Rev. 5 10-Jun-2021	Page 4A - 57
--------------------	-------------------------	--------------

NOTE

The course pointer must be at least 115° from the current magnetic heading before BC will be annunciated in the lateral mode field. Until that point, LOC will be annunciated.

Selecting NAV mode for back course approaches inhibits the glideslope from coupling.

- 6. Vertical mode and reference select on mode controller

END OF CHECKLIST

4A.6.12 GO AROUND

- 1. POWER lever MAX
- 2. FLAPS position APP
- 3. Airspeed min. 90 KIAS

When a positive rate of climb is established:

- 4. Landing gear UP, check unsafe light off
- 5. FLAPS retract, position UP

When a safe climb is established:

- 6. Fuel pumps LH/RH OFF

END OF CHECKLIST

GFC 700 Operation During Go Around

- 1. Control stick GRASP FIRMLY
- 2. GA button PUSH - verify GA/GA on
PFD in lateral and vertical mode
fields

NOTE

After the GA button is pressed, the autopilot disconnects and the flight director indicates a 6° pitch up attitude.

- 3. Balked landing execute
- 4. Missed approach procedure execute (as applicable)
- 5. Altitude preselect set to appropriate altitude

At an appropriate safe altitude:

- 6. Autopilot mode controller select appropriate lateral
and vertical mode on controller
- 7. Autopilot RE-ENGAGE if desired

NOTE

If the missed approach procedure requires tracking the localizer outbound from the airport, use NAV mode to prevent inadvertent coupling to glideslope.

END OF CHECKLIST

4A.6.13 AFTER LANDING

1. POWER lever IDLE
2. Brakes as required
3. ALTERNATE AIR CLOSED
4. Pitot heating OFF
5. Avionics as required
6. Lights as required
7. FLAPS UP
8. Fuel pumps LH/RH OFF

END OF CHECKLIST

4A.6.14 SHUT-DOWN

1. Parking brake set
2. POWER lever up to 10 % load for 1 minute
3. Engine/System Page check
4. ELT check not transmitting on
121.5 MHz
5. AVIONIC MASTER OFF
6. Electrical consumers OFF
7. ENGINE MASTER OFF
8. Anti collision lights (ACL) OFF

CAUTION

After turning the ENGINE MASTER OFF, wait until the G1000 engine indications are red X'd or yellow X'd prior to switching the ELECT. MASTER OFF. This ensures that engine and flight data can be written to non-volatile memory before removing electrical power.

9. ELECT. MASTER OFF

CAUTION

Before shut-down the engine must run for at least 1 minute with the power lever at 10% to avoid heat damage of the turbo charger.

CAUTION

Do not shut down an engine with the FUEL SELECTOR valve. The high pressure fuel pump can otherwise be damaged.

END OF CHECKLIST

Doc. No. 7.01.16-E	Rev. 5 10-Jun-2021	Page 4A - 61
--------------------	-------------------------	--------------

4A.6.15 EXIT AIRPLANE

Exit the airplane to the aft on designated areas on the inner wing section LH or RH.

4A.6.16 POST FLIGHT INSPECTION

1. Record any problem found in flight and during the post-flight check in the log book.
2. Park the airplane.
3. If necessary, moor the airplane.

END OF CHECKLIST

4A.6.17 PARKING

1. Parking brake release, use chocks
2. Airplane moor, if unsupervised for
extended period
3. Pitot probe cover

END OF CHECKLIST

4A.6.18 FLIGHT IN RAIN, SNOW OR VISIBLE MOISTURE

1. ALTERNATE AIR OPEN

CAUTION

During operation on ground ALTERNATE AIR must be CLOSED.

NOTE

Performance deteriorates in rain; this applies particularly to the take-off distance and to the maximum horizontal speed. The effect on the flight characteristics is minimal. Flight through very heavy rain or snow should be avoided because of the associated visibility problems.

END OF CHECKLIST

4A.6.19 REFUELING

CAUTION

Before refueling, the airplane must be connected to electrical ground. Grounding points: exhaust, left and right. Refer to Section 2.14 for approved fuel grades.

Use of Fuel Additives

CAUTION

Only approved fuel additives not exceeding the approved concentrations may be used; refer to Section 2.14 FUEL. The instructions of the fuel additive supplier must be followed. Failure to exactly follow the fuel additive mixing procedures during refueling can result in incorrect fuel additive concentrations, fuel system contamination and possible engine stoppage.

Fuel additives may have been already mixed into the fuel when stored. In this case make sure that the brand is approved and the concentration does not exceed the approved values.

Anti-microbial life fuel additives may be manually batch-blended into the fuel tanks. In this case introduce the additive while filling the tank after approximately the half tank is filled.

Anti-icing fuel additives should not be batch-blended into the fuel tank. The fuel additive should be injected into a stream of fuel.

Record the brand and amount of fuel additives in the airplane log every time fuel additives are added.

CONTINUED

Page 4A - 64	Rev. 5	10-Jun-2021	Doc. No. 7.01.16-E
--------------	--------	-------------	--------------------

Typical Dosing Quantities:(a) KATHON FP 1.5

Fuel Quantity				Fuel Additive *	
Liter	US gal	kg	lb	ml	oz
50	13.2	40.2	88.68	3.9	0.13
100	26.4	80.4	177.37	7.7	0.26
150	39.6	120.6	266.05	11.6	0.39
200	52.8	160.8	354.73	15.5	0.52
300	79.3	241.2	532.10	23.2	0.78

* Densities used for calculation: Fuel: 0.804 kg/l, KATHON FP 1.5: 1.04 kg/l

(b) BIOBOR JF

Fuel Quantity				Fuel Additive BIOBOR JF*			
				135 ppm		270 ppm	
Liter	US gal	kg	lb	ml	oz	ml	oz
50	13.2	40.2	88.68	5.2	0.18	10.4	0.35
100	26.4	80.4	177.37	10.4	0.35	20.9	0.71
150	39.6	120.6	266.05	15.6	0.53	31.3	1.06
200	52.8	160.8	354.73	20.9	0.71	41.8	1.42
300	79.3	241.2	532.10	31.3	1.06	62.7	2.13

* Calculation according to SB No. 982, 'Instructions for use of BIOBOR JF'

CONTINUED

(c) PRIST Hi-Flash

Fuel Quantity				Fuel Additive *,** PRIST Hi-Flash (1500 ppm)	
Liter	US gal	kg	lb	ml	oz
50	13.2	40.2	88.68	58.9	1.99
100	26.4	80.4	177.37	117.9	3.99
150	39.6	120.6	266.05	176.8	5.98
200	52.8	160.8	354.73	235.8	7.97
300	79.3	241.2	532.10	353.7	11.96

* Densities used for calculation: Fuel: 0.804 kg/l, PRIST Hi-Flash: 1.05 kg/l

** Do not batch blend

Refueling of the Auxiliary Tanks (if installed)

CAUTION

If the auxiliary tanks are used then both tanks must be refueled to the maximum level. Only then the pilot has proper information concerning the fuel quantity in the auxiliary tanks.

If the auxiliary tanks are not in use, make sure that they are empty (refer to Section 6.4 - FLIGHT MASS & CENTER OF GRAVITY).

END OF CHECKLIST

4A.6.20 FLIGHT AT HIGH ALTITUDE

At high altitudes the provision of oxygen for the occupants is necessary. Legal requirements for the provision of oxygen should be adhered to.

Also see Section 2.11 - OPERATING ALTITUDE.

4A.6.21 DEMONSTRATION OF ENGINE SHUTDOWN/RESTART

Maximum altitude 10,000 ft pressure altitude
Minimum altitude 3,000 ft above ground level

NOTE

When demonstrating handling qualities with one engine inoperative the left engine is the critical engine.

Restarting the Engine with the Starter

Maximum restart airspeed 100 KIAS or airspeed
for a stationary propeller,
whichever is lower

CAUTION

Do not engage the starter when the propeller is windmilling.

CONTINUED

Doc. No. 7.01.16-E	Rev. 5 10-Jun-2021	Page 4A - 67
--------------------	-------------------------	--------------

NOTE

At airspeeds below 100 KIAS it is possible that the propeller may windmill intermittently. Therefore, care should be taken to ensure that the propeller is stationary when engaging the starter.

1. Altitude stabilize in level flight at an altitude within the altitude limits defined above
2. Airspeed trim to 100 KIAS

The following actions must be completed in not more than two minutes.

If MÄM 42-938 (engine software VC33_2_05_19 or later approved software) is installed refer to the times shown in the table below.

OAT		Max. engine OFF time
[° C]	[° F]	[minutes]
below -15	below 5	2
-15 to -5	5 to 23	5
above -5	above 23	10

1. ENGINE MASTER of selected engine OFF, propeller feathers
2. POWER lever of selected engine IDLE
3. Airspeed stabilize between 90 to 100 KIAS
4. ENGINE MASTER of selected engine ON, propeller un-feathers
5. STARTER of selected engine engage when propeller is stationary

CONTINUED

CAUTION

After the engine has started, the POWER lever should be set to a moderate power setting until engine temperature have reached the green range.

END OF CHECKLIST

Intentionally left blank.

CHAPTER 4B

ABNORMAL OPERATING PROCEDURES

	Page
4B.1 PRECAUTIONARY LANDING	4B-3
4B.2 CANOPY IN COOLING GAP POSITION	4B-5
4B.3 ENGINE INSTRUMENT INDICATIONS OUTSIDE OF GREEN RANGE ON THE G1000	4B-6
4B.3.1 RPM	4B-6
4B.3.2 COOLANT TEMPERATURE	4B-7
4B.3.3 OIL TEMPERATURE	4B-8
4B.3.4 OIL PRESSURE	4B-9
4B.3.5 GEARBOX TEMPERATURE	4B-10
4B.3.6 FUEL TEMPERATURE	4B-10
4B.3.7 VOLTAGE	4B-11
4B.4 CAUTION-ALERTS ON THE G1000	4B-12
4B.4.1 CAUTIONS / GENERAL	4B-12
4B.4.2 L/R ECU A FAIL	4B-12
4B.4.3 L/R ECU B FAIL	4B-15
4B.4.4 L/R FUEL LOW	4B-18
4B.4.5 LOW VOLTAGE CAUTION (LOW VOLTS)	4B-19
4B.4.6 L/R ALTN FAIL	4B-20
4B.4.7 L/R COOL LVL	4B-21
4B.4.8 PITOT FAIL / HT OFF	4B-22
4B.4.9 STALL HT FAIL / OFF	4B-24
4B.4.10 L/R AUXILIARY FUEL TANK EMPTY (if installed)	4B-26

4B.4.11	STICK LIMIT	4B-27
4B.4.12	CHECK GEAR	4B-28
4B.4.13	LOI	4B-28
4B.4.14	AHRS ALIGNING - KEEP WINGS LEVEL	4B-29
4B.5	FAILURES IN FLAP OPERATING SYSTEM	4B-30
4B.6	FAILURES IN ELECTRICAL RUDDER PEDAL ADJUSTMENT .	4B-31
4B.7	FAILURES IN HYDRAULIC SYSTEM	4B-32
4B.7.1	CONTINUOUS HYDRAULIC PUMP OPERATION	4B-32
4B.7.2	HYDRAULIC PUMP FAILURE	4B-33
4B.8	STARTING ENGINE WITH EXTERNAL POWER	4B-34
4B.8.1	BEFORE STARTING ENGINE	4B-34
4B.8.2	STARTING ENGINE	4B-36
4B.9	LIGHTNING STRIKE	4B-38
4B.10	FAILURES IN THE AUTOPILOT SYSTEM	4B-39
4B.10.1	AUTOPILOT DISCONNECT (yellow AP flashing on PFD)	4B-39
4B.10.2	AUTOPILOT OVERSPEED RECOVERY (yellow MAXSPD on PFD)	4B-39
4B.10.3	LOSS OF NAVIGATION INFORMATION (Yellow VOR, VAPP, GPS or LOC flashing on PFD)	4B-40
4B.10.4	AUTOPILOT OUT OF TRIM (Yellow ←AIL, →AIL, ↑ELE, ↓ELE, ←RUD or →RUD on PFD)	4B-41
4B.10.5	FLASHING YELLOW MODE ANNUNCIATION	4B-44
4B.10.6	EFFECTS OF G1000 LOSSES UPON AUTOPILOT OPERATION	4B-45
4B.11	L/R AUX FUEL TRANSFER FAIL (IF AUX. TANKS ARE INSTALLED)	4B-46

4B.1 PRECAUTIONARY LANDING

NOTE

A landing of this type is only necessary when there is a reasonable suspicion that due to operational factors such as fuel shortage, weather conditions, etc. the possibility of endangering the airplane and its occupants by continuing the flight cannot be excluded. The pilot is required to decide whether or not a controlled landing in a field represents a lower risk than the attempt to reach the nearest airfield under all circumstances.

NOTE

If no level landing area is available, a landing on an upward slope should be sought.

- 1. Select appropriate landing area.
- 2. Consider wind.
- 3. Approach:

If possible, the landing area should be overflown at a suitable height in order to recognize obstacles. The degree of offset at each part of the circuit will allow the wind speed and direction to be assessed.

- 4. ATC advise

Perform procedures according to Normal Procedures 4A.6.11 - APPROACH & LANDING.

- 5. Touchdown with the lowest possible airspeed

CONTINUED

Doc. No. 7.01.16-E	Rev. 5 10-Jun-2021	Page 4B - 3
--------------------	-------------------------	-------------

CAUTION

If sufficient time is remaining, the risk of fire in the event of a collision with obstacles can be reduced as follows after a safe touch-down:

- 6. ENGINE MASTER both OFF
- 7. FUEL SELECTOR both OFF
- 8. ELECT. MASTER OFF

END OF CHECKLIST

4B.2 CANOPY IN COOLING GAP POSITION**CAUTION**

If take-off was inadvertently done with the canopy in the cooling gap position, do not attempt to close the canopy in flight. Land the airplane and close the canopy on ground.

4B.3 ENGINE INSTRUMENT INDICATIONS OUTSIDE OF GREEN RANGE ON THE G1000

4B.3.1 RPM

High RPM

1. Reduce power of affected engine.
2. Keep RPM within the green range using the power lever.

If the above mentioned measures do not solve the problem, refer to 3.12.3 - DEFECTIVE PROPELLER RPM REGULATING SYSTEM.

3. Land at the nearest suitable airfield.

END OF CHECKLIST

4B.3.2 COOLANT TEMPERATURE**(a) High Coolant Temperature**

Proceed according to:

3.2.2 - L/R ENG TEMP**(b) Low Coolant Temperature**

- Check G1000 for L/R COOL LVL caution message (low coolant level).

NOTE

During an extended descent from high altitudes with a low power setting coolant temperature may decrease. In this case an increase in power and a decrease in airspeed can help.

L/R COOL LVL caution message displayed:

- Reduce power on affected engine.
- Expect loss of coolant.

WARNING

A further decrease in coolant temperature must be expected. Prepare for an engine failure in accordance with 3.7.6 - ENGINE FAILURES IN FLIGHT.

END OF CHECKLIST

4B.3.3 OIL TEMPERATURE

(a) High Oil Temperature

Proceed according to:

3.2.3 - L/R OIL TEMP

(b) Low Oil Temperature

NOTE

During an extended descent from high altitudes with a low power setting oil temperature may decrease. In this case an increase in power can help.

- Increase power.
- Reduce airspeed.

END OF CHECKLIST

4B.3.4 OIL PRESSURE**(a) High Oil Pressure**

- Check oil temperature.
- Check coolant temperature.

If the temperatures are within the green range:

- Expect false oil pressure indication. Keep monitoring temperatures.

If the temperatures are outside of the green range:

- Reduce power on affected engine.

WARNING

Land at the nearest suitable airfield. Prepare for an engine failure in accordance with 3.7.6 - ENGINE FAILURES IN FLIGHT.

NOTE

At low oil temperatures high oil pressure may occur which could lead to an oil pressure warning. In this case reduce the power setting until the warning disappears and conduct the warm up with this reduced setting.

END OF CHECKLIST**(b) Low Oil Pressure**

Proceed according to:

3.2.4 - L/R OIL PRES

4B.3.5 GEARBOX TEMPERATURE

High Gearbox Temperature

Proceed according to:

3.2.5 - L/R GBOX TEMP

4B.3.6 FUEL TEMPERATURE

(a) High Fuel Temperature

Proceed according to:

3.2.6 - L/R FUEL TEMP

(b) Low Fuel Temperature

- Increase power on affected engine.
- Reduce airspeed.

CAUTION

At low ambient temperature conditions and/or at high airspeeds with low power settings, it can be assumed that the above mentioned procedure will increase the temperature(s). If the fuel temperature does not return to the green range perform a precautionary landing on the nearest suitable airfield. Prepare for an engine failure in accordance with 3.7.6 - ENGINE FAILURES IN FLIGHT.

END OF CHECKLIST

4B.3.7 VOLTAGE

(a) Low Voltage Indication on the Ground with Engines Running

- 1. ALTERNATORS check ON
- 2. Circuit breakers check

If LOW VOLTAGE CAUTION (LOW VOLTS / 4B.4.5) is still indicated on the G1000:

- Terminate flight preparation.

(b) Low Voltage During Flight

- 1. ALTERNATORS check ON
- 2. Circuit breakers check
- 3. Electrical equipment OFF if not needed

If LOW VOLTAGE CAUTION (LOW VOLTS / 4B.4.5) is still indicated on the G1000:

- Follow procedure in 4B.4.6 - L/R ALTN FAIL.

END OF CHECKLIST

4B.4 CAUTION-ALERTS ON THE G1000

The G1000 provides the following CAUTION-alerts on the PFD in the ALERT area.

4B.4.1 CAUTIONS / GENERAL

CHARACTERISTICS	<ul style="list-style-type: none"> * Amber color coded text. * Single warning chime tone of 1.5 seconds duration.
------------------------	---

4B.4.2 L/R ECU A FAIL

L/R ECU A FAIL	<ul style="list-style-type: none"> * Left / Right engine ECU A has failed or * is being tested during ECU test procedure before take-off check.
-----------------------	--

Depending on the type of failure, the ECU failure cautions are either 'non latched', i.e. the caution message disappears after the cause of the caution is no longer present or 'latched', i.e. the caution message remains until cleared through maintenance action. A 'non-latched' caution clears itself only on the active ECU. 'Non latched' caution messages can be cleared on the passive ECU by switching to that ECU with the voter switch.

(a) ECU A Caution on the Ground

1. VOTER switch check AUTO
2. ECU B caution check OFF
3. VOTER switch ECU A
4. Wait 5 seconds
5. VOTER switch AUTO

CONTINUED

If the ECU A caution persists:

- Terminate flight preparation.

END OF CHECKLIST

(b) ECU A Caution During Flight

NOTE

In case of a failure in the electronic ECU (Engine Control Unit) A the system automatically switches to ECU B.

1. ALTERNATE AIR OPEN
2. Fuel pumps LH/RH ON
3. Circuit breakers check / reset if necessary
4. VOTER switch AUTO

If the ECU A caution remains, the following ECU caution clearing procedure may be used:

WARNING

In case of a negative single engine climb rate, do not carry out this procedure unless a suitable landing site is available within gliding distance.

Depending on the cause of the ECU caution, switching to the passive (failed) ECU may lead to rough engine run, power fluctuation or temporary loss of power. In this case switch immediately back to AUTO.

When carrying out the clearing procedure be prepared for a loss of engine power.

CONTINUED

Doc. No. 7.01.16-E	Rev. 5	10-Jun-2021	Page 4B - 13
--------------------	--------	-------------	--------------

1. Safe altitude check
2. Airspeed min. 85 KIAS
3. FLAPS check UP
4. LANDING GEAR check UP
5. ECU B caution check OFF
6. VOTER switch ECU A
7. Wait 5 seconds
8. VOTER switch AUTO

If the ECU A caution persists:

- Land at the next suitable airfield.

NOTE

An ECU FAIL CAUTION is caused by various types of malfunctions. These include internal ECU problems, sensor failures or insufficient performance of air-, fuel-, or electrical supply system (e.g. air filter icing).

NOTE

If additional engine problems are observed refer to 3.7.2 - ENGINE TROUBLESHOOTING.

END OF CHECKLIST

4B.4.3 L/R ECU B FAIL

L/R ECU B FAIL	<ul style="list-style-type: none"> * Left / Right engine ECU B has failed or * is being tested during ECU test procedure before take-off check.
-----------------------	--

Depending on the type of failure, the ECU failure cautions are either 'non latched', i.e. the caution message disappears after the cause of the caution is no longer present or 'latched', i.e. the caution message remains until cleared through maintenance action. A 'non-latched' caution clears itself only on the active ECU. 'Non latched' caution messages can be cleared on the passive ECU by switching to that ECU with the voter switch.

(a) ECU B Caution on the Ground

1. VOTER switch check AUTO
2. ECU A caution check OFF
3. VOTER switch ECU B
4. Wait 5 seconds
5. VOTER switch AUTO

If the ECU B caution persists:

- Terminate flight preparation.

END OF CHECKLIST

(b) ECU B Caution During Flight

NOTE

In case of a failure in the electronic ECU (Engine Control Unit) B the system automatically switches to ECU A.

1. ALTERNATE AIR OPEN
2. Fuel pumps LH/RH ON
3. Circuit breakers check / reset if necessary
4. VOTER switch AUTO

If the ECU B caution remains, the following ECU caution clearing procedure may be used:

WARNING

In case of a negative single engine climb rate, do not carry out this procedure unless a suitable landing site is available within gliding distance.

Depending on the cause of the ECU caution, switching to the passive (failed) ECU may lead to rough engine run, power fluctuation or temporary loss of power. In this case switch immediately back to AUTO.

When carrying out the clearing procedure be prepared for a loss of engine power.

1. Safe altitude check
2. Airspeed min. 85 KIAS
3. FLAPS check UP
4. LANDING GEAR check UP

CONTINUED

Page 4B - 16	Rev. 5	10-Jun-2021	Doc. No. 7.01.16-E
--------------	--------	-------------	--------------------

- 5. ECU A caution check OFF
- 6. VOTER switch ECU B
- 7. Wait 5 seconds
- 8. VOTER switch AUTO

If the ECU B caution persists:

- Land at the next suitable airfield.

NOTE

An ECU FAIL CAUTION is caused by various types of malfunctions. These include internal ECU problems, sensor failures or insufficient performance of air-, fuel-, or electrical supply system (e.g. air filter icing).

NOTE

If additional engine problems are observed refer to 3.7.2 - ENGINE TROUBLESHOOTING.

END OF CHECKLIST

4B.4.4 L/R FUEL LOW

L/R FUEL LOW	Left / Right engine main tank fuel quantity is low.
---------------------	---

1. Fuel quantity check

CAUTION

As soon as the amount of usable fuel in the main tank is low, a caution message is displayed. The indication is calibrated for straight and level flight. The caution message may be triggered during turns which are flown with slip, or while taxiing in curves.

If L/R FUEL LOW caution is caused by un-coordinated flight:

CAUTION

Prolonged un-coordinated flight can lead to a L/R FUEL LOW caution and subsequent LOW PX warning and L/R ECU FAIL caution and can cause fuel starvation to the engine resulting in a loss of power.

2. Return to coordinated flight (not more than approx. half a ball sideslip, 3°-5° bank)

If LH & RH main tanks show remarkable different fuel quantities in flight:

- Expect loss of fuel on side with lower indication.
- Use crossfeed function to ensure fuel supply.

2. FUEL SELECTOR CROSSFEED (engine with LOW FUEL indication)

END OF CHECKLIST

Page 4B - 18	Rev. 5	10-Jun-2021	Doc. No. 7.01.16-E
--------------	--------	-------------	--------------------

4B.4.5 LOW VOLTAGE CAUTION (LOW VOLTS)**L/R VOLTS LOW**

Left / Right engine bus voltage is too low (less than 25 Volts).

Possible reasons are:

- A fault in the power supply.
- ALTERNATORS off.

Continue with 4B.3.7 - VOLTAGE.

CAUTION

If both low voltage indications are ON, expect failure of both alternators and follow 4B.4.6 - L/R ALTN FAIL.

END OF CHECKLIST

4B.4.6 L/R ALTN FAIL

L/R ALTN FAIL	Left / Right engine alternator has failed.
----------------------	--

NOTE

A L/R ALTN FAIL annunciation may be temporarily triggered during ground operation with low engine power settings. This indicates no system malfunction.

(a) One Alternator Failed

1. ALTERNATOR OFF / affected side
2. Bus voltage monitor
3. Electrical consumers reduce as practicable

END OF CHECKLIST

(b) Both Alternators Failed

Proceed according to:

3.3.1 - L/R ALTN FAIL

4B.4.7 L/R COOL LVL

L/R COOL LVL	Left / Right engine coolant level is low.
---------------------	---

A low coolant caution alert may indicate a loss of coolant. This will subsequently lead to decreased engine cooling capability / loss of engine power due to engine failure.

1. Annunciations / Engine instruments monitor

See 4B.3.2 - COOLANT TEMPERATURE.

NOTE

The indication is calibrated for straight and level flight. The caution message may be triggered during turns which are flown with slip, or while taxiing in curves.

END OF CHECKLIST

4B.4.8 PITOT FAIL / HT OFF

(a) PITOT FAIL

PITOT FAIL	Pitot heating system has failed.
-------------------	----------------------------------

- 1. PITOT HEAT check ON

NOTE

The Pitot heating caution message is displayed when there is a failure of the Pitot heating system. Prolonged operation of the Pitot heating on the ground can also cause the Pitot heating caution message to be displayed. In this case it indicates the activation of the thermal switch, which prevents overheating of the Pitot heating system on the ground. This is a normal function of the system. After a cooling period, the heating system will be switched on again automatically.

If in icing conditions:

- 2. Expect loss of static instruments.
- 3. Leave icing zone / refer to 3.12.4 - UNINTENTIONAL FLIGHT INTO ICING.

END OF CHECKLIST

█ (b) PITOT HT OFF

PITOT HT OFF	Pitot heating system is OFF.
---------------------	------------------------------

- █ 1. PITOT HEAT ON, if in rain, snow or visible moisture and if OAT is below 5 °C

NOTE

█ The Pitot heating caution message is displayed when the Pitot heating is switched OFF. Monitor OAT during the instrument scan. Switch Pitot heat ON if in rain, snow or visible moisture and if OAT is below 5°C.

END OF CHECKLIST

4B.4.9 STALL HT FAIL / OFF

(a) STAL HT FAIL

STAL HT FAIL	Stall warning heat has failed.
---------------------	--------------------------------

- 1. PITOT HEAT check ON

NOTE

The STAL HT OFF caution message is displayed when there is a failure of the stall warning heating system. Operation of the stall warning heating on the ground also causes the stall warning heating failed caution message to be displayed. In this case it indicates the activation of the thermal protection relay, which prevents overheating of the stall warning heating system on the ground. This is a normal function of the system.

If in icing conditions:

- 2. Expect loss of acoustic stall warning.
- 3. Leave icing zone / refer to 3.12.4 - UNINTENTIONAL FLIGHT INTO ICING.

END OF CHECKLIST

█ (b) STAL HT OFF

█ STAL HT OFF	Stall warning heat is off.
----------------------	----------------------------

- █ 1. PITOT HEAT ON, if in rain, snow or visible moisture and if OAT is below 5 °C
- █

NOTE

The STAL HT OFF caution message is displayed when the Pitot heating is switched OFF. Monitor OAT during the instrument scan. Swicht pitot heat ON if in rain, snow or visible moisture and if OAT is below 5°C.

END OF CHECKLIST

4B.4.10 L/R AUXILIARY FUEL TANK EMPTY (if installed)

L/R AUX FUEL E	Left / Right auxiliary fuel tank empty (displayed only when AUX PUMP switch is ON).
-----------------------	---

The auxiliary tank empty caution message indicates an empty auxiliary fuel tank while the aux. fuel pump is switched ON.

1. L/R auxiliary fuel pump OFF

END OF CHECKLIST

4B.4.11 STICK LIMIT**STICK LIMIT**

Control stick limiting system (variable elevator stop) has failed.

The variable elevator backstop is activated depending on the position of the power levers. The system has two failure modes which can be identified as follows:

- (a) Both power levers are in a position for a power setting of more than approximately 20% LOAD:

CAUTION

The variable elevator backstop is inoperative. In case of stalling with "power-on" the handling qualities and stall-characteristics are degraded significantly. Do not stall the airplane in any configuration.

- (b) At least one power lever is in a position for a power setting of less than approximately 20% LOAD:

CAUTION

The variable elevator backstop is active all the time, reducing the maximum elevator "pull"-deflection. This results in reduced elevator capacity. In this case it is important not to reduce airspeed below required minimum $v_{REF} = 84$ KIAS (up to 1900 kg (4189 lb)) or 86 KIAS (above 1900 kg (4189 lb)) during the approach for landing, especially at loading conditions with forward locations of the center of gravity.

END OF CHECKLIST

4B.4.12 CHECK GEAR

CHECK GEAR	Landing gear is not down and locked.
-------------------	--------------------------------------

1. Landing gear down / as required

NOTE

The CHECK GEAR caution message is displayed when either the flaps are in LDG position or one power lever is less than approx 20% and the landing gear is not down and locked.

END OF CHECKLIST

4B.4.13 LOI

LOI	GPS integrity is insufficient for the current phase of flight.
------------	--

(a) Enroute, Oceanic, Terminal, or Initial Approach Phase of Flight

If the LOI annunciation is displayed in the enroute, oceanic, terminal, or initial approach phase of flight, continue to navigate using the GPS equipment or revert to an alternate means of navigation other than the G1000 GPS receiver appropriate to the route and phase of flight. When continuing to use GPS navigation, position must be verified every 15 minutes using the G1000 VOR / ILS receiver or another IFR-approved navigation system.

(b) Final Approach

If the LOI annunciation is displayed while on the final approach segment, GPS based navigation will be aborted.

END OF CHECKLIST

Page 4B - 28	Rev. 5	10-Jun-2021	Doc. No. 7.01.16-E
--------------	--------	-------------	--------------------

4B.4.14 AHRS ALIGNING - KEEP WINGS LEVEL**AHRS ALIGN:
Keep Wings
Level**

The AHRS (Attitude and Heading Reference System) is aligning.

Keep wings level using standby attitude indicator.

END OF CHECKLIST

4B.5 FAILURES IN FLAP OPERATING SYSTEM

Failure in Position Indication or Function

1. FLAPS position check visually
2. Airspeed keep in white sector
(max. 113 KIAS)
3. FLAPS switch re-check all positions

Modified Approach Procedure Depending on the Available Flap Setting

NOTE

Refer to 5.3.10 - LANDING DISTANCES for landing distances with abnormal flap positions.

(a) Only UP available:

Airspeed min. 86 KIAS

Land at a flat approach angle, use power lever to control airplane speed and rate of descent.

(b) Only APP available:

Airspeed min. 84 KIAS

Land at a flat approach angle, use power lever to control airplane speed and rate of descent.

(c) Only LDG available:

Perform normal landing.

END OF CHECKLIST

Page 4B - 30	Rev. 5	10-Jun-2021	Doc. No. 7.01.16-E
--------------	--------	-------------	--------------------

4B.6 FAILURES IN ELECTRICAL RUDDER PEDAL ADJUSTMENT

Runaway of Electrical Rudder Pedal Adjustment (Optional Equipment, OÄM 42-070)

NOTE

The circuit breaker for the rudder pedal adjustment is located below the related switch, on the rear wall of the leg room.

1. Circuit breaker pull

END OF CHECKLIST

4B.7 FAILURES IN HYDRAULIC SYSTEM

4B.7.1 CONTINUOUS HYDRAULIC PUMP OPERATION

1. Landing gear indication lights check
2. Prepare for manual landing gear extension. Refer to Section 3.9.2 - MANUAL EXTENSION OF THE LANDING GEAR.

NOTE

The landing gear might extend as the hydraulic system pressure decreases. Consider for higher aerodynamic drag, resulting in degraded flight performance, increased fuel consumption and decreased range.

Unscheduled maintenance action is required after landing.

END OF CHECKLIST

4B.7.2 HYDRAULIC PUMP FAILURE

1. Landing gear indication lights check
2. Prepare for manual landing gear extension. Refer to Section 3.9.2 - MANUAL EXTENSION OF THE LANDING GEAR.

NOTE

The landing gear might extend as the hydraulic system pressure decreases. Consider for higher aerodynamic drag, resulting in degraded flight performance, increased fuel consumption and decreased range.

Unscheduled maintenance action is required after landing.

END OF CHECKLIST

4B.8 STARTING ENGINE WITH EXTERNAL POWER

4B.8.1 BEFORE STARTING ENGINE

1. Pre-flight inspection complete
2. Passengers instructed

NOTE

Ensure all the passengers have been fully briefed on the use of the seat belts, adjustable back rests (if installed), doors and emergency exits and the ban on smoking.

3. Rear door closed and locked
4. Front canopy position 1 or 2 (“cooling gap”)
5. Rudder pedals adjusted; if manual pedal adjustment is installed, verify proper locking
6. Safety harnesses all on and fastened
7. POWER lever check IDLE
8. Parking brake set
9. AVIONIC MASTER check OFF
10. GEAR selector check DOWN
11. VOTER switch check AUTO
12. ALTERNATORS check ON
13. ELECT. MASTER check OFF
14. ENGINE MASTER check OFF
15. PROPELLER check clear
16. External power connect

CONTINUED

CAUTION

When switching the external power unit ON, the electrically driven hydraulic gear pump may activate itself for 5 to 20 seconds in order to restore the system pressure. Should the pump continue to operate continuously or periodically, terminate flight. There is a malfunction in the landing gear system.

NOTE

When switching the external power unit ON, all electrical equipment, connected to the LH and RH main buses is powered.

- 17. G1000 wait until power-up completed.
Press ENT on MFD to acknowledge.

NOTE

The engine instruments are only available on the MFD after item 17 has been completed.

END OF CHECKLIST

4B.8.2 STARTING ENGINE

1. Strobe lights (ACL) ON
2. Fuel pumps LH/RH check OFF
3. ELECT. MASTER ON
4. ENGINE MASTER ON, LH side
5. Annunciations check "L ENGINE GLOW" ON

NOTE

L ENGINE GLOW is indicated only when the engine is cold.

6. Annunciations / Engine / System Page check OK / normal range

WARNING

Before starting the engine the pilot must ensure that the propeller area is free, and no persons can be endangered.

After the L ENGINE GLOW indication is extinguished:

7. START KEY START L as required / release
when engine has started

CONTINUED

CAUTION

Do not overheat the starter motor. Do not operate the starter motor for more than 10 seconds.

At ambient temperatures below -20°C it is possible that the engine will not run at the first attempt. In this case wait 60 seconds between the start attempts.

If the L/R STARTER annunciation does not extinguish after the engine has started and the START KEY has been released, set the ENGINE MASTER to OFF and investigate the problem.

- 8. Annunciations / Engine / System Page check OK / normal range
- 9. Annunciations / Starter check OFF
- 10. Annunciations / Oil pressure check OK

WARNING

If the oil pressure has not moved from the red range within 3 seconds after starting, set the ENGINE MASTER switch to OFF and investigate problem.

- 11. Circuit breakers check all in / as required
- 12. Idle RPM check, 710 ±30 RPM
- 13. External power disconnect
- 14. RH engine start with normal procedure

END OF CHECKLIST

4B.9 LIGHTNING STRIKE

1. Airspeed as low as practicable, do not exceed v_0 (refer to Section 2.2)
2. Grasp airplane controls firmly
3. Autopilot disengage (check)
4. PFD / backup instruments verify periodically
5. Continue flight under VMC
6. Land on the next suitable airfield

CAUTION

Due to possible damage to the airplane obey the following instructions:

- Avoid abrupt or full control surface movements.
- Avoid high g-loads on the airframe.
- Avoid high yaw angles.
- Avoid turbulent air as far as possible (e.g. lee effects).
- Do not fly into areas of known or forecast icing.
- Maintain VMC.

END OF CHECKLIST

4B.10 FAILURES IN THE AUTOPILOT SYSTEM

4B.10.1 AUTOPILOT DISCONNECT (yellow AP flashing on PFD)

- 1. AP DISC switch DEPRESS AND RELEASE
(to cancel disconnect tone)
- 2. Pitch trim retrim if necessary, using
the trim wheel

NOTE

The autopilot disconnect may be accompanied by a red boxed PTCH (pitch) or ROL on the PFD, indicating the axis which has failed. The autopilot cannot be re-engaged with either of these annunciations present.

END OF CHECKLIST

4B.10.2 AUTOPILOT OVERSPEED RECOVERY (yellow MAXSPD on PFD)

- 1. POWER lever reduce power

When overspeed condition is corrected:

- 2. Autopilot reselect VERTICAL MODE
(if necessary)

NOTE

Overspeed recovery mode provides a pitch up command to decelerate the airplane at or below the maximum autopilot operating speed (180 KIAS). Overspeed recovery is not active in altitude hold (ALT) or glideslope (GS) modes.

END OF CHECKLIST

Doc. No. 7.01.16-E	Rev. 5 10-Jun-2021	Page 4B - 39
--------------------	-------------------------	--------------

4B.10.3 LOSS OF NAVIGATION INFORMATION (Yellow VOR, VAPP, GPS or LOC flashing on PFD)

NOTE

If a navigation signal is lost while the autopilot is tracking it, the autopilot will roll the airplane wings level and default to roll mode (ROL).

1. Autopilot select HDG on mode controller
2. Nav source select a valid NAV source
3. Autopilot select NAV on mode controller

If on an instrument approach at the time the navigation signal is lost:

4. Missed approach procedure EXECUTE (as applicable)

END OF CHECKLIST

4B.10.4 AUTOPILOT OUT OF TRIM (Yellow ←AIL, →AIL, ↑ELE, ↓ELE, ←RUD or →RUD on PFD)

For ↑ELE, or ↓ELE Indication:

WARNING

Do not attempt to overpower the autopilot in the event of a pitch mistrim. The autopilot servos will oppose pilot input and will cause pitch trim to run opposite the direction of pilot input. This will lead to a significant out-of-trim condition resulting in large control stick force when disengaging the autopilot.

CAUTION

Be prepared for significant sustained control forces in the direction of the annunciation arrow. For example, an arrow pointing down indicates nose down control stick force will be required upon autopilot disconnect.

NOTE

Momentary illumination (5 sec or less) of the ↑ELE or ↓ELE indication during configuration or large airspeed changes is normal.

If the annunciation remains:

- 1. AP DISC switch DEPRESS AND HOLD
while grasping control stick firmly

CONTINUED

Doc. No. 7.01.16-E	Rev. 5 10-Jun-2021	Page 4B - 41
--------------------	-------------------------	--------------

- 2. Airplane attitude maintain / regain
airplane control,
use standby attitude indicator if
necessary
- 3. Pitch trim retrim if necessary, using
the trim wheel
- 4. AUTOPILOT circuit breaker PULL
- 5. AP DISC switch RELEASE

WARNING

Following an autopilot, autotrim or manual electric trim system malfunction, do not engage the autopilot or operate the manual electric trim until the cause of the malfunction has been corrected.

END OF CHECKLIST

For →AIL, ←AIL or →RUD, ←RUD Indication:

- 1. Rudder trim VERIFY slip / skid indicator is
centered, trim is necessary

NOTE

Observe the maximum fuel imbalance limitation.

CONTINUED

Page 4B - 42	Rev. 5	10-Jun-2021	Doc. No. 7.01.16-E
--------------	--------	-------------	--------------------

If annunciation remains:

- 2. Control stick GRASP FIRMLY with both hands

CAUTION

Be prepared for sustained control forces in the direction of the annunciation arrow. For example, an →AIL indicates that sustained right wing down control stick force or for →RUD sustained right rudder force will be required upon autopilot disconnect.

- 3. AP DISC switch DEPRESS
- 4. Autopilot RE-ENGAGE if lateral trim is re-established

END OF CHECKLIST

4B.10.5 FLASHING YELLOW MODE ANNUNCIATION

NOTE

Abnormal mode transitions (those not initiated by the pilot or by normal sequencing of the autopilot) will be annunciated by flashing the disengaged mode in yellow on the PFD. Upon loss of a selected mode, the system will revert to the default mode for the affected axis, either ROL or PIT. After 10 seconds, the new mode (PIT or ROL) will be annunciated in green.

Loss of Selected Vertical Mode (FLC, VS, ALT, GS)

1. Autopilot mode controls select another vertical mode

If on an instrument approach:

2. Autopilot DISCONNECT and continue manually or execute missed approach

Loss of Selected Lateral Mode (HDG, NAV, GPS, LOC, VAPP, BC):

1. Autopilot mode controls select another lateral mode

If on an instrument approach:

2. Autopilot DISCONNECT and continue manually or execute missed approach

END OF CHECKLIST

4B.10.6 EFFECTS OF G1000 LOSSES UPON AUTOPILOT OPERATION

G1000 System Loss	Effect upon Autopilot Operation
AHRS	The autopilot disconnects and autopilot, yaw damper and flight director are inoperative. Manual electric trim is available.
HDG function of AHRS	The autopilot will remain engaged with the loss of the HDG Mode.
MFD	The autopilot will remain engaged with limited functionality.
PFD	The autopilot disconnects and autopilot and flight director are inoperative. Manual electric trim is available.
GIA No. 1	The autopilot disconnects and autopilot, flight director and manual electric trim are inoperative.
GIA No. 2	The autopilot disconnects and autopilot and manual electric trim are inoperative. Flight director is available.
GPS No. 1 and 2	The autopilot and flight director operates in NAV modes only (LOC, BC, VOR, VAPP) with reduced accuracy.
ADC	The autopilot disconnects and autopilot is inoperative. The flight director is available except for air data modes (ALT, VS, FLC). Manual electric trim is available.

**4B.11 L/R AUX FUEL TRANSFER FAIL (IF AUX. TANKS ARE
INSTALLED)**

If the fuel quantity in a main tank does not increase during fuel transfer:

1. Switch OFF both AUX PUMPS.
2. Check fuel pump LH/RH OFF.

CAUTION

An imbalance in the auxiliary tanks is approved when the imbalance in the main tanks is less than 1 US gal (3.8 liters).

2. Check fuel imbalance in the main tanks; use CROSSFEED function to keep the LH and RH main tank imbalance within the permissible limit of 1 US gal (3.8 liters).
3. Switch the remaining AUX PUMP ON.
4. Use crossfeed function to keep the LH and RH main tank imbalance within the permissible limit of 1 US gal (3.8 liters).

END OF CHECKLIST

CHAPTER 5

PERFORMANCE

	Page
5.1 INTRODUCTION	5-2
5.2 USE OF THE PERFORMANCE TABLES AND DIAGRAMS	5-2
5.3 PERFORMANCE TABLES AND DIAGRAMS	5-3
5.3.1 AIRSPEED CALIBRATION	5-3
5.3.2 FUEL FLOW	5-4
5.3.3 INTERNATIONAL STANDARD ATMOSPHERE	5-5
5.3.4 STALLING SPEEDS	5-6
5.3.5 WIND COMPONENTS	5-8
5.3.6 TAKE-OFF DISTANCE	5-9
5.3.7 CLIMB PERFORMANCE (ALL ENGINES OPERATING) ...	5-17
5.3.8 ONE ENGINE INOPERATIVE CLIMB PERFORMANCE ...	5-22
5.3.9 TIME, FUEL AND DISTANCE TO CLIMB	5-25
5.3.10 CRUISE PERFORMANCE	5-28
5.3.11 LANDING DISTANCES	5-31
5.3.12 GO-AROUND CLIMB PERFORMANCE	5-41
5.3.13 APPROVED NOISE DATA	5-44

5.1 INTRODUCTION

The performance tables and diagrams on the following pages are presented so that, on the one hand, you can see what performance you can expect from your airplane, while on the other hand they allow comprehensive and sufficiently accurate flight planning. The values in the tables and the diagrams were obtained in the framework of the flight trials using an airplane and power-plant in good condition, and corrected to the conditions of the International Standard Atmosphere (ISA = 15 °C / 59 °F and 1013.25 hPa / 29.92 inHg at sea level).

The performance diagrams and tables do not take into account variations in pilot experience or a poorly maintained airplane. The performances given can be attained if the procedures quoted in this manual are applied, and the airplane has been well maintained.

5.2 USE OF THE PERFORMANCE TABLES AND DIAGRAMS

In order to illustrate the influence of a number of different variables, the performance data is reproduced in the form of tables or diagrams. These contain sufficiently detailed information so that conservative values can be selected and used for the determination of adequate performance data for the planned flight.

For a conversion of units see Chapter 1.6 - UNITS OF MEASUREMENT.

For temperatures, altitudes and weights between those provided, use a linear interpolation between the neighboring values.

- For weights below 1700 kg (3968 lb), use data for the lowest weight.

For operation in outside air temperature lower than provided in these tables, use data for lowest temperature shown.

Use extreme caution for operation at outside air temperature higher than provided in the tables (areas are indicated with a diagonal line).

5.3 PERFORMANCE TABLES AND DIAGRAMS

5.3.1 AIRSPEED CALIBRATION

NOTE

The position of the landing gear (extended/retracted) has no significant influence on the airspeed indicator system.

Airspeed Indicator Calibration			
Indicated Airspeed [KIAS]	Calibrated Airspeed [KCAS] at Various Flap Settings		
	UP	APP	LDG
75	not applicable		73
80	79	80	78
85	85	85	82
90	90	90	87
95	96	95	92
100	101	101	97
105	106	106	101
110	112	111	106
115	117	116	111
120	122	121	not applicable
125	128	126	
130	133	132	
135	138	137	
140	143		
150	154		
160	164		
170	174		
180	184		
190	194		

5.3.2 FUEL FLOW

CAUTION

The table shows the fuel flow per hour for one engine.

NOTE

The fuel calculations on the FUEL CALC portion of the G1000 MFD do not use the airplane's fuel quantity indicators. The values shown are numbers which are calculated from the last fuel quantity update done by the pilot and actual fuel flow data. Therefore, the endurance and range data is for information only, and must not be used for flight planning.

Fuel Flow		
Power Setting [%]	Fuel Flow [US gal / h]	Fuel Flow [Liter / h]
30	2.9	11
35	3.3	12.5
40	3.6	14
45	4.0	15.5
50	4.4	16.5
55	4.8	18
60	5.2	19.5
65	5.6	21
70	6.0	22.5
75	6.5	24.5
80	7.0	26.5
85	7.5	28.5
90	8.0	30.5
92	8.3	31.5
100	9.3	35.5

5.3.3 INTERNATIONAL STANDARD ATMOSPHERE

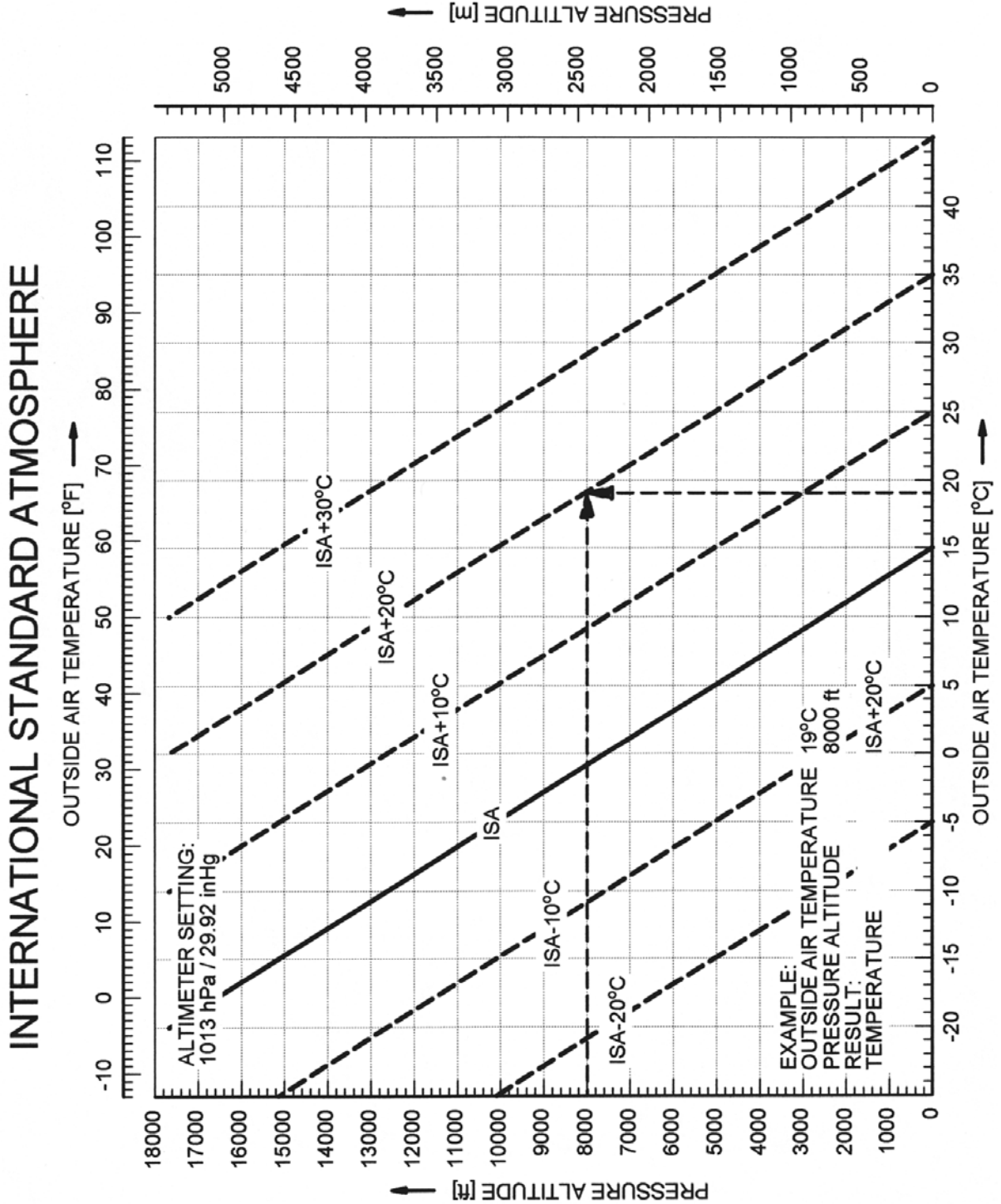

5.3.4 STALLING SPEEDS

Stalling Speeds at Various Flight Masses

Airspeeds, most forward CG, power off:

1510 kg (3329 lb)		Bank Angle							
		0°		30°		45°		60°	
Gear	Flaps	KIAS	KCAS	KIAS	KCAS	KIAS	KCAS	KIAS	KCAS
UP	UP	61	59	66	64	72	71	84	84
DOWN	APP	58	57	63	62	69	68	81	81
DOWN	LDG	54	54	60	59	67	65	79	77

1700 kg (3748 lb)		Bank Angle							
		0°		30°		45°		60°	
Gear	Flaps	KIAS	KCAS	KIAS	KCAS	KIAS	KCAS	KIAS	KCAS
UP	UP	64	62	68	67	75	74	88	88
DOWN	APP	62	61	66	66	73	73	86	86
DOWN	LDG	59	58	64	62	71	69	86	82

1900 kg (4189 lb)		Bank Angle							
		0°		30°		45°		60°	
Gear	Flaps	KIAS	KCAS	KIAS	KCAS	KIAS	KCAS	KIAS	KCAS
UP	UP	68	66	72	71	79	78	93	93
DOWN	APP	65	64	70	69	77	76	90	91
DOWN	LDG	62	61	67	66	75	73	89	86

1999 kg (4407 lb)		Bank Angle							
		0°		30°		45°		60°	
Gear	Flaps	KIAS	KCAS	KIAS	KCAS	KIAS	KCAS	KIAS	KCAS
UP	UP	72	70	76	76	84	84	99	100
DOWN	APP	68	67	73	72	80	80	95	95
DOWN	LDG	64	62	69	67	76	74	91	88

NOTE

KIAS values may not be accurate at stall.

5.3.5 WIND COMPONENTS

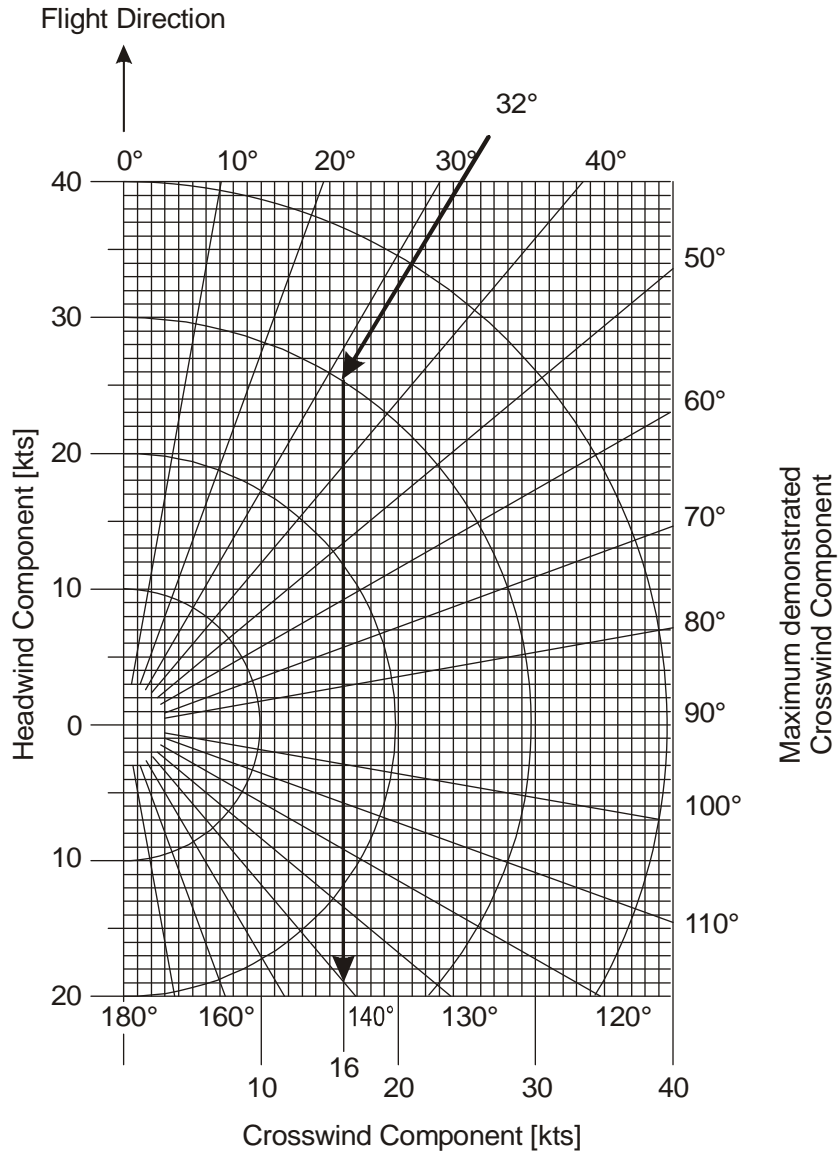

Example: Flight direction : 320°
 Wind : 32°/30 kts
 Result: Crosswind component : 16 kts
 Max. demonstrated crosswind component : 25 kts

5.3.6 TAKE-OFF DISTANCE

Conditions:

- Power lever both MAX
- Flaps UP or APP
- Runway dry, paved, level
- Nose wheel lift-off @ V_R
- Airspeed for initial climb @ V_{50}

The following factors are to be applied to the computed take-off distance for the noted condition:

- Headwind: Decrease by 10% for each 14 kt (7.2 m/s) headwind.
- Tailwind: Increase by 10% for each 3 kt (1.5 m/s) tailwind.
- Grass runway, dry, 5 cm (2 in) long: Increase the ground roll by 10%.
- Grass runway, dry, 5 cm (2 in) to 10 cm (3.9 in) long: Increase the ground roll by 15%.
- Grass runway, dry, 25 cm (9.8 in) long: Increase the ground roll by 25%.
- Grass runway, longer than 25 cm (9.8 in): A take-off should not be attempt.
- Grass runway, wet: Increase the dry grass runway distance calculation by 10%.
- Soft ground: Increase the ground roll by 45% (in addition to the grass runway distance calculation, if applicable).
- Uphill slope: Increase the ground roll by 9% for each 1% (1 m per 100 m or 1 ft per 100 ft) slope.

If brakes are not held while applying power, distances apply where full power setting is complete.

Doc. No. 7.01.16-E	Rev. 5 10-Jun-2021	Page 5 - 9
--------------------	-------------------------	------------

WARNING

For a safe take-off the available runway length must be at least equal to the take-off distance over a 50 ft (15 m) obstacle.

WARNING

Poor maintenance condition of the airplane, deviation from the given procedures, uneven runway, as well as unfavorable external factors (rain, unfavorable wind conditions, including cross-wind) will increase the take-off distance.

CAUTION

The factors in the above corrections are typical values. On wet ground or wet soft grass covered runways the take-off roll may become significantly longer than stated above. In any case the pilot must allow for the condition of the runway to ensure a safe take-off.

The above corrections for runway slope should be used with caution since published runway slope data is usually the net slope from one end of the runway to the other. Runways may have positions at their length at greater or lesser slopes than published slope, lengthening (or shortening) the take-off roll estimated with these tables.

NOTE

The effect of 50% of the headwind component and 150% of the tailwind component is already incorporated in the head- and tailwind factors.

Take-Off Distance - Normal Procedure - 1999 kg / 4407 lb								
Weight: 1999 kg / 4407 lb			Flaps: UP					
V _R : 76 KIAS			Power: MAX					
V ₅₀ : 83 KIAS			Runway: dry, paved, level					
Press. Alt. [ft] / [m]	Distance [m]	Outside Air Temperature - [°C] / [°F]						ISA
		0 / 32	10 / 50	20 / 68	30 / 86	40 / 104	50 / 122	
SL	Ground Roll	400	420	440	470	560	680	424
	15 m / 50 ft	730	760	790	870	1050	1330	776
1000 305	Ground Roll	420	440	470	510	610	730	444
	15 m / 50 ft	760	800	840	930	1150	1450	804
2000 610	Ground Roll	440	460	500	540	660	790	462
	15 m / 50 ft	800	840	890	1000	1260	1570	836
3000 914	Ground Roll	460	490	520	590	710	860	485
	15 m / 50 ft	840	880	940	1080	1360	1710	869
4000 1219	Ground Roll	490	520	560	640	780	930	505
	15 m / 50 ft	880	920	1000	1170	1490	1850	906
5000 1524	Ground Roll	520	550	600	690	840		531
	15 m / 50 ft	920	980	1070	1280	1620		944
6000 1829	Ground Roll	550	580	640	760	920		556
	15 m / 50 ft	970	1030	1140	1400	1760		986
7000 2134	Ground Roll	580	620	680	820	990		582
	15 m / 50 ft	1030	1100	1220	1530	1910		1029
8000 2438	Ground Roll	620	660	730	900	1080		611
	15 m / 50 ft	1090	1170	1320	1660	2080		1078
9000 2743	Ground Roll	660	710	800	980	1180		642
	15 m / 50 ft	1150	1240	1450	1840	2280		1128
10000 3048	Ground Roll	700	770	900	1100			676
	15 m / 50 ft	1230	1360	1640	2110			1182

For the distance in [ft] divide by 0.3048 or multiply by 3.28.

Take-Off Distance - Normal Procedure - 1900 kg / 4189 lb								
Weight: 1900 kg / 4189 lb				Flaps: UP				
V _R : 76 KIAS				Power: MAX				
V ₅₀ : 83 KIAS				Runway: dry, paved, level				
Press. Alt. [ft] / [m]	Distance [m]	Outside Air Temperature - [°C] / [°F]						ISA
		0 / 32	10 / 50	20 / 68	30 / 86	40 / 104	50 / 122	
SL	Ground Roll	370	390	410	450	520	640	400
	15 m / 50 ft	670	710	730	800	960	1210	716
1000 305	Ground Roll	390	410	440	480	570	690	417
	15 m / 50 ft	710	740	780	860	1060	1310	743
2000 610	Ground Roll	420	440	470	510	620	750	435
	15 m / 50 ft	740	770	820	920	1150	1420	773
3000 914	Ground Roll	440	460	490	550	670	810	456
	15 m / 50 ft	770	810	870	990	1250	1550	803
4000 1219	Ground Roll	460	490	530	600	730	880	477
	15 m / 50 ft	810	850	920	1080	1350	1670	838
5000 1524	Ground Roll	490	520	560	650	790		500
	15 m / 50 ft	850	900	990	1180	1470		874
6000 1829	Ground Roll	520	550	600	710	860		523
	15 m / 50 ft	900	950	1050	1280	1600		910
7000 2134	Ground Roll	550	590	640	780	930		549
	15 m / 50 ft	950	1010	1130	1400	1740		951
8000 2438	Ground Roll	580	620	690	840	1010		577
	15 m / 50 ft	1000	1080	1210	1520	1880		995
9000 2743	Ground Roll	620	670	760	920	1110		606
	15 m / 50 ft	1060	1150	1330	1680	2090		1040
10000 3048	Ground Roll	660	720	840	1030			638
	15 m / 50 ft	1140	1250	1500	1910			1094

For the distance in [ft] divide by 0.3048 or multiply by 3.28.

Take-Off Distance - Normal Procedure - 1700 kg / 3748 lb								
Weight: 1700 kg / 3748 lb			Flaps: UP					
V _R : 76 KIAS			Power: MAX					
V ₅₀ : 83 KIAS			Runway: dry, paved, level					
Press. Alt. [ft] / [m]	Distance [m]	Outside Air Temperature - [°C] / [°F]						ISA
		0 / 32	10 / 50	20 / 68	30 / 86	40 / 104	50 / 122	
SL	Ground Roll	330	350	360	390	460	560	350
	15 m / 50 ft	580	600	630	680	810	1010	613
1000 305	Ground Roll	350	360	390	420	500	600	367
	15 m / 50 ft	598	630	670	730	890	1100	633
2000 610	Ground Roll	370	390	410	450	540	650	384
	15 m / 50 ft	630	660	700	780	970	1190	661
3000 914	Ground Roll	390	410	440	480	590	710	401
	15 m / 50 ft	660	700	740	840	1050	1290	689
4000 1219	Ground Roll	410	430	460	530	640	770	420
	15 m / 50 ft	700	730	790	910	1140	1390	717
5000 1524	Ground Roll	430	460	490	580	700		439
	15 m / 50 ft	730	770	840	1000	1240		748
6000 1829	Ground Roll	460	490	530	630	760		461
	15 m / 50 ft	770	820	900	1090	1340		779
7000 2134	Ground Roll	480	520	560	680	820		483
	15 m / 50 ft	810	870	960	1180	1450		815
8000 2438	Ground Roll	520	550	610	740	890		507
	15 m / 50 ft	860	920	1030	1290	1570		853
9000 2743	Ground Roll	550	590	670	810	970		532
	15 m / 50 ft	910	980	1130	1410	1740		891
10000 3048	Ground Roll	590	640	740	910			560
	15 m / 50 ft	980	1070	1270	1600			935

For the distance in [ft] divide by 0.3048 or multiply by 3.28.

Take-Off Distance - Short Field Procedure - 1999 kg / 4407 lb

Weight: 1999 kg / 4407 lb

Flaps: APP

V_R: 74 KIAS

Power: MAX

V₅₀: 79 KIAS

Runway: dry, paved, level

Press. Alt. [ft] / [m]	Distance [m]	Outside Air Temperature - [°C] / [°F]						ISA
		0 / 32	10 / 50	20 / 68	30 / 86	40 / 104	50 / 122	
SL	Ground Roll	350	370	390	420	500	610	375
	15 m / 50 ft	600	640	670	730	890	1120	649
1000 305	Ground Roll	370	390	410	450	540	660	392
	15 m / 50 ft	640	670	710	790	980	1230	676
2000 610	Ground Roll	390	410	440	490	590	720	411
	15 m / 50 ft	670	710	760	850	1080	1360	707
3000 914	Ground Roll	410	440	470	530	650	790	430
	15 m / 50 ft	710	750	810	930	1180	1500	739
4000 1219	Ground Roll	440	460	500	580	710	860	453
	15 m / 50 ft	750	790	870	1020	1300	1640	776
5000 1524	Ground Roll	470	490	540	630	780		477
	15 m / 50 ft	790	840	930	1130	1440		812
6000 1829	Ground Roll	500	530	580	690	850		500
	15 m / 50 ft	840	900	1000	1240	1590		854
7000 2134	Ground Roll	530	560	620	760	930		526
	15 m / 50 ft	900	960	1080	1380	1750		899
8000 2438	Ground Roll	560	600	670	830	1010		556
	15 m / 50 ft	950	1030	1180	1520	1940		946
9000 2743	Ground Roll	600	650	740	920	1120		585
	15 m / 50 ft	1020	1110	1320	1710	2200		999
10000 3048	Ground Roll	650	710	840	1040			618
	15 m / 50 ft	1100	1230	1520	2010			1055

For the distance in [ft] divide by 0.3048 or multiply by 3.28.

Take-Off Distance - Short Field Procedure - 1900 kg / 4189 lb								
Weight: 1900 kg / 4189 lb			Flaps: APP					
V _R : 71 KIAS			Power: MAX					
V ₅₀ : 77 KIAS			Runway: dry, paved, level					
Press. Alt. [ft] / [m]	Distance [m]	Outside Air Temperature - [°C] / [°F]						ISA
		0 / 32	10 / 50	20 / 68	30 / 86	40 / 104	50 / 122	
SL	Ground Roll	330	350	370	400	470	570	354
	15 m / 50 ft	560	590	620	680	820	1030	603
1000 305	Ground Roll	350	370	390	430	510	630	371
	15 m / 50 ft	590	620	660	730	900	1130	630
2000 610	Ground Roll	370	390	420	460	560	680	388
	15 m / 50 ft	620	660	700	790	990	1240	657
3000 914	Ground Roll	390	410	440	500	610	740	407
	15 m / 50 ft	660	690	750	860	1090	1360	686
4000 1219	Ground Roll	410	440	470	540	670	810	427
	15 m / 50 ft	700	740	800	940	1190	1490	718
5000 1524	Ground Roll	440	470	510	600	730	/	448
	15 m / 50 ft	740	780	860	1040	1310	/	755
6000 1829	Ground Roll	470	500	540	650	800	/	472
	15 m / 50 ft	780	840	930	1140	1440	/	793
7000 2134	Ground Roll	500	530	590	720	870	/	496
	15 m / 50 ft	830	890	1000	1260	1590	/	833
8000 2438	Ground Roll	530	570	640	780	950	/	524
	15 m / 50 ft	890	960	1090	1390	1750	/	877
9000 2743	Ground Roll	570	610	700	860	1050	/	551
	15 m / 50 ft	950	1030	1210	1550	1980	/	924
10000 3048	Ground Roll	610	670	790	980	/	/	583
	15 m / 50 ft	1020	1140	1380	1810	/	/	977

For the distance in [ft] divide by 0.3048 or multiply by 3.28.

Take-Off Distance - Short Field Procedure - 1700 kg / 3748 lb

Weight: 1700 kg / 3748 lb

Flaps: APP

V_R: 71 KIAS

Power: MAX

V₅₀: 77 KIAS

Runway: dry, paved, level

Press. Alt. [ft] / [m]	Distance [m]	Outside Air Temperature - [°C] / [°F]						ISA
		0 / 32	10 / 50	20 / 68	30 / 86	40 / 104	50 / 122	
SL	Ground Roll	290	310	320	350	410	500	311
	15 m / 50 ft	490	510	540	590	700	870	521
1000 305	Ground Roll	310	320	340	380	450	550	326
	15 m / 50 ft	510	540	570	630	770	950	544
2000 610	Ground Roll	330	350	370	410	490	600	342
	15 m / 50 ft	540	570	610	680	840	1040	567
3000 914	Ground Roll	350	360	390	440	540	650	358
	15 m / 50 ft	570	600	650	730	920	1140	592
4000 1219	Ground Roll	370	390	420	480	590	710	376
	15 m / 50 ft	600	640	690	810	1010	1250	622
5000 1524	Ground Roll	390	410	450	520	640		396
	15 m / 50 ft	640	680	740	880	1100		651
6000 1829	Ground Roll	410	440	480	580	700		416
	15 m / 50 ft	680	720	800	970	1210		684
7000 2134	Ground Roll	440	470	520	630	770		437
	15 m / 50 ft	720	770	860	1070	1330		719
8000 2438	Ground Roll	470	500	560	690	840		461
	15 m / 50 ft	760	820	930	1170	1460		755
9000 2743	Ground Roll	500	540	620	760	930		487
	15 m / 50 ft	820	880	1030	1300	1630		797
10000 3048	Ground Roll	540	590	690	860			513
	15 m / 50 ft	880	970	1170	1500			839

For the distance in [ft] divide by 0.3048 or multiply by 3.28.

5.3.7 CLIMB PERFORMANCE (ALL ENGINES OPERATING)

Conditions:

- Power lever both 92%
- Flaps UP or APP
- Landing gear retracted
- Airspeed v_Y

The climb performance tables show the rate of climb. The gradient of climb can be calculated using the following formula:

$$Gradient [\%] = \frac{ROC [fpm]}{TAS [KTAS]} \cdot 0.98$$

NOTE

Rate of climb at MTOM (1900 kg / 4189 lb) with a power setting of 100% at MSL and ISA conditions:

- 1337 ft/min (6.8 m/s) with flaps UP
- 1267 ft/min (6.4 m/s) with flaps APP

NOTE

If MÄM 42-678 is installed, the rate of climb at MTOM (1999 kg / 4407 lb) with a power setting of 100% at MSL and ISA conditions:

- 1243 ft/min (6.3 m/s) with flaps UP
- 1183 ft/min (6.0 m/s) with flaps APP

All Engines Operating Climb - Flaps UP

Flaps: UP

Power: 92%

v_y: 92 KIAS above 1900 kg (4189 lb)

Gear: retracted

90 KIAS up to 1900 kg (4189 lb)

Weight [kg] / [lb]	Press. Alt. [ft]	Press. Alt. [m]	Rate of Climb - [ft/min]								ISA
			Outside Air Temperature - [°C] / [°F]								
			-20 -4	-10 14	0 32	10 50	20 68	30 86	40 104	50 122	
1999 / 4407	SL		1120	1120	1120	1110	1110	1100	1040	880	1114
	2000	610	1120	1110	1110	1100	1090	1090	970	820	1103
	4000	1219	1110	1100	1090	1090	1080	1050	900	760	1092
	6000	1829	1090	1090	1080	1070	1070	990	840	/	1081
	8000	2438	1080	1070	1060	1050	1040	930	780	/	1069
	10000	3048	1060	1050	1040	1040	990	820	/	/	1052
	12000	3658	1040	1030	1020	1020	850	680	/	/	1033
	14000	4267	1020	1020	960	830	660	520	/	/	1021
	16000	4877	1010	940	820	680	540	/	/	/	1007
	18000	5486	890	800	700	560	410	/	/	/	895
1900 / 4189	SL		1210	1210	1200	1200	1200	1190	1130	960	1203
	2000	610	1200	1200	1200	1190	1180	1180	1050	890	1193
	4000	1219	1200	1190	1180	1170	1170	1140	98	830	1181
	6000	1829	1180	1170	1170	1160	1150	1080	920	/	1169
	8000	2438	1170	1160	1150	1150	1130	1010	860	/	1158
	10000	3048	1150	1140	1130	1130	1080	900	/	/	1144
	12000	3658	1130	1120	1120	1110	930	750	/	/	1124
	14000	4267	1110	1110	1050	920	740	590	/	/	1113
	16000	4877	1100	1030	910	760	610	/	/	/	1102
	18000	5486	980	890	780	630	480	/	/	/	986

All Engines Operating Climb - Flaps UP											
Flaps: UP						Power: 92%					
v _y : 92 KIAS above 1900 kg (4189 lb)						Gear: retracted					
90 KIAS up to 1900 kg (4189 lb)											
Weight [kg] / [lb]	Press. Alt. [ft]	Press. Alt. [m]	Rate of Climb - [ft/min]								
			Outside Air Temperature - [°C] / [°F]								ISA
			-20 -4	-10 14	0 32	10 50	20 68	30 86	40 104	50 122	
1700 / 3748	SL		1380	1380	1380	1380	1370	1370	1290	1100	1378
	2000	610	1380	1380	1370	1360	1360	1350	1210	1030	1368
	4000	1219	1370	1360	1360	1350	1340	1320	1130	960	1357
	6000	1829	1360	1350	1340	1340	1330	1240	1060		1345
	8000	2438	1340	1340	1330	1320	1310	1170	1000		1334
	10000	3048	1330	1320	1310	1300	1250	1050			1320
	12000	3658	1310	1300	1290	1290	1080	890			1299
	14000	4267	1290	1290	1220	1070	870	710			1289
	16000	4877	1280	1200	1070	900	730				1278
	18000	5486	1140	1040	930	760	590				1151

For the rate of climb in [m/s] divide by 196.8 or multiply by 0.00508.

All Engines Operating Climb - Flaps APP											
Flaps: APP						Power: 92%					
v _y : 85 KIAS						Gear: retracted					
Weight [kg] / [lb]	Press. Alt. [ft]	Press. Alt. [m]	Rate of Climb - [ft/min]								
			Outside Air Temperature - [°C] / [°F]								ISA
			-20 -4	-10 14	0 32	10 50	20 68	30 86	40 104	50 122	
1999 / 4407	SL		1080	1070	1060	1050	1040	1030	980	820	1052
	2000	610	1060	1050	1040	1030	1020	1010	890	750	1036
	4000	1219	1040	1030	1020	1010	1000	970	820	680	1020
	6000	1829	1020	1010	1000	980	970	900	750	/	997
	8000	2438	1000	980	970	950	940	830	690	/	973
	10000	3048	970	950	940	930	880	720	/	/	949
	12000	3658	940	920	910	900	730	570	/	/	923
	14000	4267	910	900	840	710	540	410	/	/	904
	16000	4877	890	810	700	560	410	/	/	/	883
	18000	5486	760	670	570	430	280	/	/	/	769
1900 / 4189	SL		1160	1150	1140	1130	1120	1110	1050	880	1129
	2000	610	1140	1130	1120	1110	1100	1090	960	810	1112
	4000	1219	1120	1110	1100	1090	1070	1050	890	740	1096
	6000	1829	1100	1090	1070	1060	1050	970	820	/	1073
	8000	2438	1070	1060	1040	1030	1020	900	750	/	1049
	10000	3048	1040	1030	1010	1000	950	780	/	/	1024
	12000	3658	1010	990	980	970	800	620	/	/	998
	14000	4267	980	970	910	780	600	460	/	/	978
	16000	4877	960	880	760	610	460	/	/	/	957
	18000	5486	830	730	630	480	320	/	/	/	838

All Engines Operating Climb - Flaps APP											
Flaps: APP						Power: 92%					
v _γ : 85 KIAS						Gear: retracted					
Weight [kg] / [lb]	Press. Alt. [ft]	Press. Alt. [m]	Rate of Climb - [ft/min]								
			Outside Air Temperature - [°C] / [°F]								ISA
			-20 -4	-10 14	0 32	10 50	20 68	30 86	40 104	50 122	
1700 / 3748	SL		1330	1320	1300	1290	1280	1270	1210	1020	1294
	2000	610	1310	1290	1280	1270	1260	1250	1110	930	1277
	4000	1219	1280	1270	1260	1250	1240	1210	1030	860	1260
	6000	1829	1260	1250	1240	1220	1210	1130	950		1236
	8000	2438	1240	1220	1200	1190	1180	1050	870		1210
	10000	3048	1200	1190	1170	1160	1110	910			1184
	12000	3658	1170	1150	1140	1130	930	740			1156
	14000	4267	1140	1130	1060	910	710	550			1136
	16000	4877	1120	1030	900	730	560				1114
	18000	5486	980	870	750	580	410				983

For the rate of climb in [m/s] divide by 196.8 or multiply by 0.00508.

5.3.8 ONE ENGINE INOPERATIVE CLIMB PERFORMANCE

Conditions:

- Remaining engine 92% load
- Dead engine feathered and secured
- Flaps UP
- Landing gear retracted
- Airspeed $V_{YSE} = 85$ KIAS
- Sideslip one ball out, max. 5° bank

NOTE

With respect to handling and performance, the left-hand engine (pilots view) is considered the "critical" engine.

The climb performance tables show the rate of climb. The gradient of climb can be calculated using the following formula:

$$\textit{Gradient} [\%] = \frac{ROC [fpm]}{TAS [KTAS]} \cdot 0.98$$

One Engine Inoperative Climb												
Flaps: UP						Power: feathered / 92%						
V _{YSE} : 85 KIAS						Gear: retracted						
Weight [kg] / [lb]	Press. Alt. [ft]	Press. Alt. [m]	Rate of Climb - [ft/min]									
			Outside Air Temperature - [°C] / [°F]									
			-20 -4	-10 14	0 32	10 50	20 68	30 86	40 104	50 122	ISA	
1999 / 4407	SL		270	255	245	235	225	210	185	120	230	
	2000	610	245	235	220	210	200	190	140	80	212	
	4000	1219	225	210	200	185	175	160	95	40	193	
	6000	1829	200	185	175	160	150	120	55	/	170	
	8000	2438	175	160	145	130	120	75	15	/	147	
	10000	3048	145	130	115	100	80	10	/	/	123	
	12000	3658	115	95	85	70	0	-70	/	/	97	
	14000	4267	85	70	35	-30	-105	-160	/	/	75	
	16000	4877	55	10	-50	-120	-180	/	/	/	50	
	18000	5486	-25	-75	-135	-195	-255	/	/	/	-19	
1900 / 4189	SL		305	295	285	270	260	250	225	155	269	
	2000	610	285	270	260	250	240	225	175	110	250	
	4000	1219	260	250	235	225	210	195	130	70	231	
	6000	1829	235	225	210	195	185	155	90	/	208	
	8000	2438	210	195	180	165	155	110	45	/	184	
	10000	3048	180	165	150	140	115	40	/	/	160	
	12000	3658	150	135	120	110	30	-45	/	/	134	
	14000	4267	120	105	70	0	-75	-135	/	/	111	
	16000	4877	90	45	-20	-90	-155	/	/	/	86	
	18000	5486	10	-45	-105	-170	-235	/	/	/	14	

One Engine Inoperative Climb

Flaps: UP

Power: feathered / 92%

V_{YSE}: 85 KIAS

Gear: retracted

Weight [kg] / [lb]	Press. Alt. [ft]	Press. Alt. [m]	Rate of Climb - [ft/min]								
			Outside Air Temperature - [°C] / [°F]								ISA
			-20 -4	-10 14	0 32	10 50	20 68	30 86	40 104	50 122	
1700 / 3748	SL		390	375	365	355	345	330	300	220	350
	2000	610	365	355	340	330	320	305	245	170	331
	4000	1219	340	330	315	305	290	275	200	125	311
	6000	1829	320	305	290	275	265	225	150		287
	8000	2438	290	275	260	245	230	180	105		263
	10000	3048	260	245	230	215	190	100			237
	12000	3658	225	210	195	185	95	10			210
	14000	4267	195	180	140	65	-25	-90			186
	16000	4877	165	115	45	-35	-110				161
	18000	5486	80	20	-45	-120	-195				83

CAUTION: Dark grey shaded areas indicate a climb rate of less than 50 ft/min.

For the rate of climb in [m/s] divide by 196.8 or multiply by 0.00508.

5.3.9 TIME, FUEL AND DISTANCE TO CLIMB

Conditions:

- Power lever both 92%
- Flaps UP
- Landing gear retracted
- Airspeed V_Y

NOTE

Distances shown are based on zero wind. Fuel for start, taxi and take-off not included. Add 10% to the time, fuel and distance for each 10° C (12° F) increase in OAT.

Example:

- OAT at take-off 11°C (52°F)
- Airfield pressure altitude 2000 ft (1200 m)
- Initial climb weight 1900 kg (4189 lb)
- OAT at cruise -17° C (2° F)
- Cruise altitude 16000 ft (4900 m)

Time, fuel and distance to climb at airfield: 2 min, 0.5 US gal and 3 NM (1)

Time, fuel and distance to climb at cruise: 14 min, 3.8 US gal and 24 NM (2)

Subtract (1) from (2) to obtain time, fuel and distance to climb from airfield to cruise:

Time to cruise altitude: 14 min - 2 min = 12 min

Fuel to cruise altitude: 3.8 US gal - 0.5 US gal = 3.3 US gal

Distance to cruise altitude: 24 NM - 3 NM = 21 NM

Time, Fuel and Distance to Climb

Flaps: UP

v_y: 92 KIAS (above 1900 kg / 4189 lb)

Power: 92%

v_y: 90 KIAS (up to 1900 kg / 4189 lb)

Gear: retracted

Weight [kg] / [lb]	Press. Alt. [ft]	Press. Alt. [m]	OAT [°C]	OAT [°F]	TAS [kt]	RoC [ft/min]	RoC [m/s]	Time [min]	Fuel [US gal]	Distance [NM]
1999 / 4407	SL		15	59	92	1115	5.7	0	0	0
	2000	600	11	52	93	1110	5.6	2	0.5	3
	4000	1219	7	45	95	1105	5.6	4	1	6
	6000	1829	3	38	96	1095	5.6	5	1.5	9
	8000	2438	-1	30	98	1090	5.5	7	2	12
	10000	3048	-5	23	99	1085	5.5	9	2.5	15
	12000	3658	-9	16	101	1080	5.5	11	3.1	19
	14000	4267	-13	9	102	1070	5.4	13	3.6	22
	16000	4877	-17	2	104	1065	5.4	15	4.2	26
	18000	5486	-21	-5	106	1050	5.3	17	4.7	30
1900 / 4189	SL		15	59	90	1205	6.1	0	0	0
	2000	600	11	52	91	1200	6.1	2	0.5	3
	4000	1219	7	45	93	1195	6.1	3	0.9	5
	6000	1829	3	38	94	1185	6.0	5	1.4	8
	8000	2438	-1	30	96	1180	6.0	7	1.9	11
	10000	3048	-5	23	97	1175	6.0	9	2.4	14
	12000	3658	-9	16	99	1170	5.9	10	2.8	17
	14000	4267	-13	9	100	1160	5.9	12	3.3	20
	16000	4877	-17	2	102	1155	5.9	14	3.8	24
	18000	5486	-21	-5	104	1140	5.8	16	4.4	27

Time, Fuel and Distance to Climb

Flaps: UP

v_y: 92 KIAS (above 1900 kg / 4189 lb)

Power: 92%

v_y: 90 KIAS (up to 1900 kg / 4189 lb)

Gear: retracted

Weight [kg] / [lb]	Press. Alt.	Press. Alt.	OAT	OAT	TAS	RoC	RoC	Time	Fuel	Distance
	[ft]	[m]	[°C]	[°F]	[kt]	[ft/min]	[m/s]	[min]	[US gal]	[NM]
1700 / 3748	SL		15	59	90	1380	7.0	0	0	0
	2000	600	11	52	91	1375	7.0	1	0.4	2
	4000	1219	7	45	93	1370	6.9	3	0.8	5
	6000	1829	3	38	94	1360	6.9	4	1.2	7
	8000	2438	-1	30	96	1355	6.9	6	1.6	9
	10000	3048	-5	23	97	1350	6.9	7	2.0	12
	12000	3658	-9	16	99	1345	6.8	9	2.5	15
	14000	4267	-13	9	100	1335	6.8	10	2.9	17
	16000	4877	-17	2	102	1330	6.8	12	3.3	20
	18000	5486	-21	-5	104	1315	6.7	14	3.8	24

5.3.10 CRUISE PERFORMANCE

Conditions:

- Flaps UP
- Landing gear retracted
- Weight 1999 kg

For conversion of OAT to delta-ISA temperatures refer to Chapter 5.3.3 - INTERNATIONAL STANDARD ATMOSPHERE.

Cruise Performance															
Press. Alt. [ft] / [m]	Outside Air Temperature - [°C]														
	ISA-10			ISA			ISA+10			ISA+20			ISA+30		
	Pwr [%]	FF [US gal/h]	TAS [kt]	Pwr [%]	FF [US gal/h]	TAS [kt]	Pwr [%]	FF [US gal/h]	TAS [kt]	Pwr [%]	FF [US gal/h]	TAS [kt]	Pwr [%]	FF [US gal/h]	TAS [kt]
2000 610	92	16.6	164	92	16.6	166	92	16.6	168	92	16.7	170	89	16.3	169
	75	13.2	152	75	13.2	153	75	13.2	155	75	13.2	157	75	13.2	158
	60	10.3	138	60	10.3	139	60	10.3	141	60	10.3	142	60	10.3	144
	35	6.5	102	35	6.5	103	35	6.5	103	35	6.5	104	35	6.5	104
4000 1219	92	16.6	168	92	16.6	169	92	16.6	171	92	16.7	173	90	16.5	173
	75	13.2	154	75	13.2	156	75	13.2	158	75	13.2	159	75	13.2	161
	60	10.3	140	60	10.3	142	60	10.3	143	60	10.3	145	60	10.3	146
	35	6.5	103	35	6.5	104	35	6.5	104	35	6.5	104	35	6.5	105
6000 1829	92	16.6	171	92	16.6	173	92	16.6	175	92	16.7	176	90	16.4	176
	75	13.2	157	75	13.2	159	75	13.2	161	75	13.2	163	75	13.2	164
	60	10.3	143	60	10.3	144	60	10.3	146	60	10.3	147	60	10.3	149
	35	6.5	104	35	6.5	104	35	6.5	105	35	6.5	105	35	6.5	105
8000 2438	92	16.6	174	92	16.6	176	92	16.6	178	92	16.7	180	92	16.8	181
	75	13.2	160	75	13.2	162	75	13.2	164	75	13.2	166	75	13.2	167
	60	10.3	145	60	10.3	147	60	10.3	149	60	10.3	150	60	10.3	151
	40	7.3	117	40	7.3	118	40	7.3	118	40	7.3	119	40	7.3	120
10000 3048	92	16.6	177	92	16.6	179	92	16.6	181	92	16.7	183	90	16.4	183
	75	13.2	163	75	13.2	165	75	13.2	167	75	13.2	169	75	13.2	170
	60	10.3	148	60	10.3	150	60	10.3	151	60	10.3	153	60	10.3	154
	45	8.1	128	45	8.1	129	45	8.1	130	45	8.1	131	45	8.1	131
12000 3658	92	16.6	181	92	16.6	183	92	16.6	185	92	16.8	187	90	16.2	184
	75	13.2	166	75	13.2	168	75	13.2	170	75	13.2	172	75	13.2	173
	60	10.3	151	60	10.3	152	60	10.3	154	60	10.3	155	60	10.3	157
	45	8.1	129	45	8.1	130	45	8.1	131	45	8.1	132	45	8.1	133
14000 4267	92	16.7	184	92	16.7	186	92	16.8	188	85	15.4	184	80	14.5	182
	75	13.2	169	75	13.2	171	75	13.2	173	75	13.2	175	75	13.2	177
	60	10.3	153	60	10.3	155	60	10.3	156	60	10.3	158	60	10.3	159
	45	8.1	131	45	8.1	132	50	8.8	142	50	8.8	143	50	8.8	144

Cruise Performance															
Press. Alt. [ft] / [m]	Outside Air Temperature - [°C]														
	ISA-10			ISA			ISA+10			ISA+20			ISA+30		
	Pwr [%]	FF [US gal/h]	TAS [kt]	Pwr [%]	FF [US gal/h]	TAS [kt]	Pwr [%]	FF [US gal/h]	TAS [kt]	Pwr [%]	FF [US gal/h]	TAS [kt]	Pwr [%]	FF [US gal/h]	TAS [kt]
16000 4877	92	16.8	188	92	16.8	190	90	16.5	189	85	15.5	186	80	14.5	183
	75	13.2	173	75	13.2	175	75	13.2	176	75	13.2	178	75	13.2	180
	60	10.3	156	60	10.3	157	60	10.3	159	60	10.3	161	60	10.3	162
	50	8.7	142	50	8.7	143	50	8.7	144	50	8.7	145	50	8.7	146
18000 5486	85	15.4	185	85	15.5	188	85	15.5	189	80	14.5	186	80	14.0	184
	75	13.2	176	75	13.2	178	75	13.2	180	75	13.2	182	75	13.5	183
	60	10.3	159	60	10.3	160	60	10.3	162	60	10.3	163	60	10.3	165
	50	8.7	144	50	8.7	145	50	8.7	146	50	8.7	147	50	8.7	148

5.3.11 LANDING DISTANCES

Conditions:

- Power lever both IDLE
- Flaps LDG, APP or UP
- Runway dry, paved, level
- Approach speed V_{REF}

The following factors are to be applied to the computed landing distance for the noted condition:

- Headwind: Decrease by 10% for each 14 kt (7.2 m/s) headwind.
- Tailwind: Increase by 10% for each 3 kt (1.5 m/s) tailwind.
- Paved runway, wet: Increase by 15%.
- Grass runway, dry, 5 cm (2 in) long: Increase the ground roll by 10%.
- Grass runway, dry, 5 cm (2 in) to 10 cm (3.9 in) long: Increase the ground roll by 15%.
- Grass runway, dry, longer than 10 cm (3.9 in): Increase the ground roll at least by 25%.
- Grass runway, wet or soft runway: Increase the ground roll by 10%.
- Downhill slope: Increase the ground roll by 9% for each 1% (1 m per 100 m or 1 ft per 100 ft) of slope.

WARNING

For a safe landing the available runway length must be at least equal to the landing distance over a 50 ft (15 m) obstacle.

WARNING

Poor maintenance condition of the airplane, deviation from the given procedures, uneven runway, as well as unfavorable external factors (rain, unfavorable wind conditions, including cross-wind) will increase the landing distance.

CAUTION

The factors in the above corrections are typical values. On wet ground or wet soft grass covered runways the landing distance may become significantly longer than stated above. In any case the pilot must allow for the condition of the runway to ensure a safe landing.

The above corrections for runway slope should be used with caution since published runway slope data is usually the net slope from one end of the runway to the other. Runways may have positions at their length at greater or lesser slopes than published slope, lengthening (or shortening) the landing roll estimated with these tables.

NOTE

The effect of 50% of the headwind component and 150% of the tailwind component is already incorporated in the head- and tailwind factors.

Landing Distance - Flaps LDG - 1999 kg / 4407 lb								
Weight: 1999 kg / 4407 lb			Flaps: LDG					
V_{REF}: 86 KIAS			Power: IDLE					
Runway: dry, paved, level								
Press. Alt. [ft] / [m]	Distance [m]	Outside Air Temperature - [°C] / [°F]						ISA
		0 / 32	10 / 50	20 / 68	30 / 86	40 / 104	50 / 122	
SL	Ground Roll	370	380	400	410	440	500	387
	15 m / 50 ft	620	640	660	680	730	820	647
1000 305	Ground Roll	380	400	410	420	470	530	399
	15 m / 50 ft	640	660	680	700	770	860	662
2000 610	Ground Roll	400	410	430	440	490	550	411
	15 m / 50 ft	660	680	700	720	810	900	680
3000 914	Ground Roll	410	430	440	460	520	580	422
	15 m / 50 ft	680	700	720	750	840	940	697
4000 1219	Ground Roll	430	440	460	490	550	610	435
	15 m / 50 ft	700	720	750	790	890	990	715
5000 1524	Ground Roll	440	460	480	510	580	/	449
	15 m / 50 ft	730	750	770	830	930	/	734
6000 1829	Ground Roll	460	480	490	540	610	/	461
	15 m / 50 ft	750	770	800	870	980	/	753
7000 2134	Ground Roll	480	500	520	580	650	/	479
	15 m / 50 ft	780	810	830	930	1030	/	780
8000 2438	Ground Roll	510	530	550	630	700	/	507
	15 m / 50 ft	820	850	880	990	1110	/	818
9000 2743	Ground Roll	550	570	610	690	770	/	542
	15 m / 50 ft	870	900	950	1070	1200	/	862
10000 3048	Ground Roll	600	620	670	750	/	/	584
	15 m / 50 ft	930	960	1040	1160	/	/	913

For the distance in [ft] divide by 0.3048 or multiply by 3.28.

Landing Distance - Flaps LDG - 1900 kg / 4189 lb

Weight: 1900 kg / 4189 lb

Flaps: LDG

V_{REF}: 84 KIAS

Power: IDLE

Runway: dry, paved, level

Press. Alt. [ft] / [m]	Distance [m]	Outside Air Temperature - [°C] / [°F]						ISA
		0 / 32	10 / 50	20 / 68	30 / 86	40 / 104	50 / 122	
SL	Ground Roll	360	370	380	390	430	480	372
	15 m / 50 ft	600	620	630	650	700	780	620
1000 305	Ground Roll	370	380	390	410	450	500	381
	15 m / 50 ft	620	630	650	670	740	820	635
2000 610	Ground Roll	380	390	410	420	470	530	392
	15 m / 50 ft	630	650	670	690	770	860	652
3000 914	Ground Roll	400	410	420	440	500	560	405
	15 m / 50 ft	650	670	690	720	810	910	668
4000 1219	Ground Roll	410	420	440	460	520	590	415
	15 m / 50 ft	670	700	720	760	850	950	685
5000 1524	Ground Roll	420	440	450	490	550	/	428
	15 m / 50 ft	700	720	740	800	900	/	704
6000 1829	Ground Roll	440	450	470	520	580	/	442
	15 m / 50 ft	720	740	770	840	940	/	722
7000 2134	Ground Roll	460	480	490	550	620	/	459
	15 m / 50 ft	750	780	800	890	1000	/	751
8000 2438	Ground Roll	490	510	530	600	670	/	488
	15 m / 50 ft	790	820	850	960	1070	/	788
9000 2743	Ground Roll	530	550	580	660	740	/	523
	15 m / 50 ft	840	870	920	1030	1160	/	832
10000 3048	Ground Roll	580	590	640	730	/	/	562
	15 m / 50 ft	900	930	1000	1120	/	/	884

For the distance in [ft] divide by 0.3048 or multiply by 3.28.

Landing Distance - Flaps LDG - 1805 kg / 3979 lb								
Weight:		1805 kg / 3979 lb			Flaps: LDG			
V_{REF}:		84 KIAS			Power: IDLE			
Runway: dry, paved, level								
Press. Alt. [ft] / [m]	Distance [m]	Outside Air Temperature - [°C] / [°F]						ISA
		0 / 32	10 / 50	20 / 68	30 / 86	40 / 104	50 / 122	
SL	Ground Roll	334	347	360	370	401	451	353
	15 m / 50 ft	573	590	607	625	672	753	598
1000 305	Ground Roll	347	360	371	384	423	473	364
	15 m / 50 ft	590	608	626	644	705	790	613
2000 610	Ground Roll	360	371	385	399	445	500	373
	15 m / 50 ft	608	627	645	663	741	827	629
3000 914	Ground Roll	372	386	400	415	470	528	385
	15 m / 50 ft	628	646	665	691	777	866	645
4000 1219	Ground Roll	386	401	413	440	494	553	397
	15 m / 50 ft	647	667	687	726	816	909	661
5000 1524	Ground Roll	399	414	429	463	522	/	407
	15 m / 50 ft	668	689	709	764	856	/	679
6000 1829	Ground Roll	415	431	444	490	552	/	420
	15 m / 50 ft	690	710	732	803	898	/	696
7000 2134	Ground Roll	435	451	465	523	588	/	437
	15 m / 50 ft	719	741	764	852	952	/	721
8000 2438	Ground Roll	466	484	503	571	638	/	465
	15 m / 50 ft	760	783	814	917	1025	/	758
9000 2743	Ground Roll	506	522	556	626	703	/	500
	15 m / 50 ft	809	835	884	995	1109	/	802
10000 3048	Ground Roll	550	570	615	694	/	/	540
	15 m / 50 ft	868	894	964	1082	/	/	855

For the distance in [ft] divide by 0.3048 or multiply by 3.28.

Landing Distance - Flaps LDG - 1700 kg / 3748 lb

Weight: 1700 kg / 3748 lb

Flaps: LDG

V_{REF}: 84 KIAS

Power: IDLE

Runway: dry, paved, level

Press. Alt. [ft] / [m]	Distance [m]	Outside Air Temperature - [°C] / [°F]						ISA
		0 / 32	10 / 50	20 / 68	30 / 86	40 / 104	50 / 122	
SL	Ground Roll	320	340	350	360	390	430	335
	15 m / 50 ft	550	570	590	600	650	730	577
1000 305	Ground Roll	340	350	360	370	410	460	346
	15 m / 50 ft	570	590	610	620	680	760	591
2000 610	Ground Roll	350	360	370	380	430	480	356
	15 m / 50 ft	590	610	630	640	720	800	605
3000 914	Ground Roll	360	370	380	400	450	500	367
	15 m / 50 ft	610	630	640	670	750	840	621
4000 1219	Ground Roll	370	380	400	420	480	530	376
	15 m / 50 ft	630	650	660	700	790	880	636
5000 1524	Ground Roll	390	400	410	450	500	/	388
	15 m / 50 ft	650	670	690	740	830	/	652
6000 1829	Ground Roll	400	410	430	470	530	/	401
	15 m / 50 ft	670	690	710	780	870	/	670
7000 2134	Ground Roll	420	440	450	500	560	/	417
	15 m / 50 ft	690	720	740	820	920	/	693
8000 2438	Ground Roll	450	460	490	550	610	/	445
	15 m / 50 ft	740	760	790	890	990	/	731
9000 2743	Ground Roll	490	510	540	610	680	/	481
	15 m / 50 ft	790	810	860	960	1070	/	775
10000 3048	Ground Roll	530	550	600	670	/	/	522
	15 m / 50 ft	850	870	940	1050	/	/	828

For the distance in [ft] divide by 0.3048 or multiply by 3.28.

Landing Distance - Abnormal Flap Position - 1999 kg / 4407 lb								
Weight: 1999 kg / 4407 lb			Flaps: APP or UP					
V _{REF} : 92 KIAS			Power: IDLE					
Runway: dry, paved, level								
Press. Alt. [ft] / [m]	Distance [m]	Outside Air Temperature - [°C] / [°F]						ISA
		0 / 32	10 / 50	20 / 68	30 / 86	40 / 104	50 / 122	
SL	Ground Roll	510	530	550	560	610	680	532
	15 m / 50 ft	860	880	910	940	1010	1130	894
1000 305	Ground Roll	530	550	570	580	640	720	548
	15 m / 50 ft	880	910	940	970	1060	1180	916
2000 610	Ground Roll	550	570	580	610	680	760	565
	15 m / 50 ft	910	940	970	1000	1110	1240	938
3000 914	Ground Roll	570	590	610	630	710	800	580
	15 m / 50 ft	940	970	1000	1040	1160	1300	963
4000 1219	Ground Roll	590	610	630	670	750	840	598
	15 m / 50 ft	970	1000	1030	1090	1220	1360	987
5000 1524	Ground Roll	610	630	650	700	790		614
	15 m / 50 ft	1000	1030	1060	1150	1290		1014
6000 1829	Ground Roll	630	650	680	740	830		634
	15 m / 50 ft	1030	1070	1100	1200	1350		1040
7000 2134	Ground Roll	660	680	710	790	890		659
	15 m / 50 ft	1080	1110	1150	1280	1430		1080
8000 2438	Ground Roll	700	730	760	860	960		698
	15 m / 50 ft	1140	1180	1220	1380	1540		1136
9000 2743	Ground Roll	760	780	830	940	1050		745
	15 m / 50 ft	1210	1250	1320	1490	1660		1200
10000 3048	Ground Roll	810	840	910	1030			799
	15 m / 50 ft	1300	1340	1440	1620			1276

For the distance in [ft] divide by 0.3048 or multiply by 3.28.

Landing Distance - Abnormal Flap Position - 1900 kg / 4189 lb
Weight: 1900 kg / 4189 lb

Flaps: APP or UP

V_{REF}: 86 KIAS

Power: IDLE

Runway: dry, paved, level

Press. Alt. [ft] / [m]	Distance [m]	Outside Air Temperature - [°C] / [°F]						ISA
		0 / 32	10 / 50	20 / 68	30 / 86	40 / 104	50 / 122	
SL	Ground Roll	490	510	520	540	580	650	511
	15 m / 50 ft	820	840	870	890	960	1080	852
1000 305	Ground Roll	510	520	540	560	610	690	524
	15 m / 50 ft	840	870	900	920	1010	1130	874
2000 610	Ground Roll	520	540	560	580	650	730	540
	15 m / 50 ft	870	900	920	950	1060	1180	895
3000 914	Ground Roll	540	560	580	610	680	760	554
	15 m / 50 ft	900	930	950	990	1110	1240	919
4000 1219	Ground Roll	560	580	600	640	720	800	572
	15 m / 50 ft	930	950	980	1040	1170	1300	942
5000 1524	Ground Roll	580	600	620	670	760		590
	15 m / 50 ft	960	990	1010	1090	1220		966
6000 1829	Ground Roll	600	630	650	710	800		606
	15 m / 50 ft	990	1020	1050	1150	1290		992
7000 2134	Ground Roll	630	660	680	760	850		633
	15 m / 50 ft	1030	1060	1090	1220	1360		1030
8000 2438	Ground Roll	680	700	730	830	920		672
	15 m / 50 ft	1090	1130	1170	1320	1470		1085
9000 2743	Ground Roll	730	750	800	900	1010		717
	15 m / 50 ft	1160	1200	1270	1430	1590		1150
10000 3048	Ground Roll	790	820	880	990			772
	15 m / 50 ft	1250	1290	1390	1560			1227

For the distance in [ft] divide by 0.3048 or multiply by 3.28.

Landing Distance - Abnormal Flap Position - 1805 kg / 3979 lb								
Weight: 1805 kg / 3979 lb			Flaps: APP or UP					
V _{REF} : 86 KIAS			Power: IDLE					
Runway: dry, paved, level								
Press. Alt. [ft] / [m]	Distance [m]	Outside Air Temperature - [°C] / [°F]						ISA
		0 / 32	10 / 50	20 / 68	30 / 86	40 / 104	50 / 122	
SL	Ground Roll	462	477	494	511	551	621	485
	15 m / 50 ft	780	804	827	850	916	1025	816
1000 305	Ground Roll	477	495	513	528	582	652	500
	15 m / 50 ft	804	828	852	877	961	1076	835
2000 610	Ground Roll	495	514	530	548	613	688	516
	15 m / 50 ft	829	853	879	904	1010	1127	856
3000 914	Ground Roll	514	531	550	572	647	723	529
	15 m / 50 ft	854	881	906	942	1059	1182	879
4000 1219	Ground Roll	532	552	569	605	681	763	546
	15 m / 50 ft	882	908	936	989	1112	1239	901
5000 1524	Ground Roll	552	571	591	638	720		560
	15 m / 50 ft	909	938	966	1041	1167		925
6000 1829	Ground Roll	572	593	612	675	757		578
	15 m / 50 ft	940	968	998	1093	1226		948
7000 2134	Ground Roll	599	622	642	720	810		602
	15 m / 50 ft	983	1013	1044	1165	1302		987
8000 2438	Ground Roll	643	667	694	786	880		641
	15 m / 50 ft	1044	1075	1118	1258	1406		1041
9000 2743	Ground Roll	693	719	762	862	963		688
	15 m / 50 ft	1116	1150	1217	1368	1527		1104
10000 3048	Ground Roll	755	783	844	953			742
	15 m / 50 ft	1201	1236	1332	1494			1183

For the distance in [ft] divide by 0.3048 or multiply by 3.28.

Landing Distance - Abnormal Flap Position - 1700 kg / 3748 lb
Weight: 1700 kg / 3748 lb

Flaps: APP or UP

V_{REF}: 86 KIAS

Power: IDLE

Runway: dry, paved, level

Press. Alt. [ft] / [m]	Distance [m]	Outside Air Temperature - [°C] / [°F]						ISA
		0 / 32	10 / 50	20 / 68	30 / 86	40 / 104	50 / 122	
SL	Ground Roll	450	460	480	490	530	600	464
	15 m / 50 ft	750	780	800	820	880	990	783
1000 305	Ground Roll	460	480	490	510	560	630	478
	15 m / 50 ft	780	800	820	850	930	1040	802
2000 610	Ground Roll	480	490	510	530	590	660	492
	15 m / 50 ft	800	820	850	870	970	1080	821
3000 914	Ground Roll	490	510	530	550	620	690	505
	15 m / 50 ft	820	850	870	910	1020	1140	843
4000 1219	Ground Roll	510	530	550	580	650	730	521
	15 m / 50 ft	850	880	900	950	1070	1190	864
5000 1524	Ground Roll	530	550	570	610	690	/	535
	15 m / 50 ft	880	900	930	1000	1120	/	887
6000 1829	Ground Roll	550	570	590	650	730	/	552
	15 m / 50 ft	910	930	960	1050	1180	/	910
7000 2134	Ground Roll	580	600	620	690	780	/	577
	15 m / 50 ft	950	980	1000	1120	1250	/	945
8000 2438	Ground Roll	620	640	670	760	850	/	614
	15 m / 50 ft	1010	1040	1080	1210	1360	/	1001
9000 2743	Ground Roll	670	700	740	830	930	/	662
	15 m / 50 ft	1080	1110	1170	1320	1470	/	1064
10000 3048	Ground Roll	730	760	820	920	/	/	717
	15 m / 50 ft	1160	1200	1290	1450	/	/	1144

For the distance in [ft] divide by 0.3048 or multiply by 3.28.

5.3.12 GO-AROUND CLIMB PERFORMANCE

Conditions:

- Power lever both MAX
- Flaps LDG
- Landing gear extended
- Airspeed:
 - Up to 1900 kg (4189 lb) $V_{REF} = 84$ KIAS
 - Above 1900 kg (4189 lb) $V_{REF} = 86$ KIAS

The climb performance charts show the rate of climb. The gradient and angle of climb can be calculated using the following formula:

$$Gradient [\%] = \frac{ROC [fpm]}{TAS [KTAS]} \cdot 0.98$$

NOTE

The angles of climb at MSL and ISA condition are:

4.7° for Maximum Take-Off Mass (1900 kg / 4189 lb)

5.1° for Maximum Landing Mass (1805 kg / 3979 lb)

If MÄM 42-678 is carried out:

3.9° for Maximum Take-Off Mass (1999 kg / 4407 lb)

Go-Around Climb Performance

Flaps: LDG

Power: MAX

V_{REF}: 86 KIAS above 1900 kg (4189 lb)

Gear: extended

84 KIAS up to 1900 kg (4189 lb)

Weight [kg] / [lb]	Press. Alt. [ft]	Press. Alt. [m]	Rate of Climb - [ft/min]								
			Outside Air Temperature - [°C] / [°F]								ISA
			-20 -4	-10 14	0 32	10 50	20 68	30 86	40 104	50 122	
1999 / 4407	SL		635	620	600	585	570	505	375	240	580
	2000	610	605	585	570	550	515	425	280	155	552
	4000	1219	570	550	530	510	450	340	200	80	517
	6000	1829	530	505	485	455	380	250	120	/	480
	8000	2438	485	460	440	400	310	170	45	/	443
	10000	3048	440	415	380	310	190	40	/	/	405
1900 / 4189	SL		735	715	700	685	670	605	470	325	678
	2000	610	700	685	665	650	620	525	375	240	652
	4000	1219	670	650	635	615	555	440	290	160	622
	6000	1829	635	610	590	560	485	345	210	/	585
	8000	2438	590	565	545	505	410	265	135	/	548
	10000	3048	545	520	485	415	290	135	/	/	509
1805 / 3979	SL		794	777	760	744	728	659	518	366	735
	2000	610	761	744	726	710	675	578	420	276	708
	4000	1219	727	709	693	671	611	488	330	193	677
	6000	1829	693	670	647	614	536	390	244	/	640
	8000	2438	647	623	600	557	462	304	165	/	602
	10000	3048	599	574	539	465	333	169	/	/	562

Go-Around Climb Performance											
Flaps: LDG						Power: MAX					
V _{REF} : 86 KIAS above 1900 kg (4189 lb)						Gear: extended					
84 KIAS up to 1900 kg (4189 lb)											
Weight [kg] / [lb]	Press. Alt. [ft]	Press. Alt. [m]	Rate of Climb - [ft/min]								
			Outside Air Temperature - [°C] / [°F]								ISA
			-20 -4	-10 14	0 32	10 50	20 68	30 86	40 104	50 122	
1700 / 3748	SL		865	845	830	810	795	725	575	410	805
	2000	610	830	810	795	775	740	640	470	315	777
	4000	1219	795	775	760	735	675	545	375	225	746
	6000	1829	760	735	710	680	595	440	285	/	707
	8000	2438	710	685	665	620	520	350	200	/	667
	10000	3048	660	635	600	520	380	205	/	/	626

For the rate of climb in [m/s] divide by 196.8 or multiply by 0.00508.

5.3.13 APPROVED NOISE DATA

Max. Flight Mass 1900 kg (4189 lb)

ICAO Annex 16 Chapter X, App.6 73.8 dB(A)

If MÄM 42-678 is installed:

Max. Flight Mass 1999 kg (4407 lb)

ICAO Annex 16 Chapter X, App.6 75.0 dB(A)

CHAPTER 6

MASS AND BALANCE

	Page
6.1 INTRODUCTION	6-2
6.2 DATUM PLANE	6-3
6.3 MASS AND BALANCE REPORT	6-4
6.4 FLIGHT MASS AND CENTER OF GRAVITY	6-6
6.4.1 MOMENT ARMS	6-8
6.4.2 LOADING DIAGRAM	6-10
6.4.3 CALCULATION OF LOADING CONDITION	6-12
6.4.4 PERMISSIBLE CENTER OF GRAVITY RANGE	6-15
6.4.5 PERMISSIBLE MOMENT RANGE	6-17
6.5 EQUIPMENT LIST AND EQUIPMENT INVENTORY	6-18

6.1 INTRODUCTION

In order to achieve the performance and flight characteristics described in this Airplane Flight Manual and for safe flight operation, the airplane must be operated within the permissible mass and balance envelope.

The pilot is responsible for adhering to the permissible values for loading and center of gravity (CG). In this, he should note the movement of the CG due to fuel consumption. The permissible CG range during flight is given in Chapter 2.

The procedure for determining the flight mass CG position is described in this chapter. Additionally a comprehensive list of the equipment approved for this airplane exists (Equipment List). The set of items marked as 'installed' constitutes the *Equipment Inventory*.

Before the airplane is delivered, the empty mass and the corresponding CG position are determined and entered in Section 6.3 - MASS AND BALANCE REPORT.

NOTE

Following equipment changes the new empty mass and the corresponding CG position must be determined by calculation or by weighing.

Following repairs or repainting the new empty mass and the corresponding CG position must be determined by weighing.

Empty mass, empty mass CG position, and the empty mass moment must be certified in the Mass and Balance Report by authorized personnel.

NOTE

Refer to Section 1.6 - UNITS OF MEASUREMENT for conversion of SI units to US units and vice versa.

NOTE

The mass of the winter kit - ventilation is negligible. The mass and balance data of the airplane therefore remain unchanged.

6.2 DATUM PLANE

The Datum Plane (DP) is a plane which is normal to the airplane's longitudinal axis and in front of the airplane as seen from the direction of flight. The airplane's longitudinal axis is parallel with the floor of the nose baggage compartment. When the floor of the nose baggage compartment is aligned horizontally, the Datum Plane is vertical. The Datum Plane is located 2.196 meters (86.46 in) forward of the most forward point of the root rib on the stub wing.

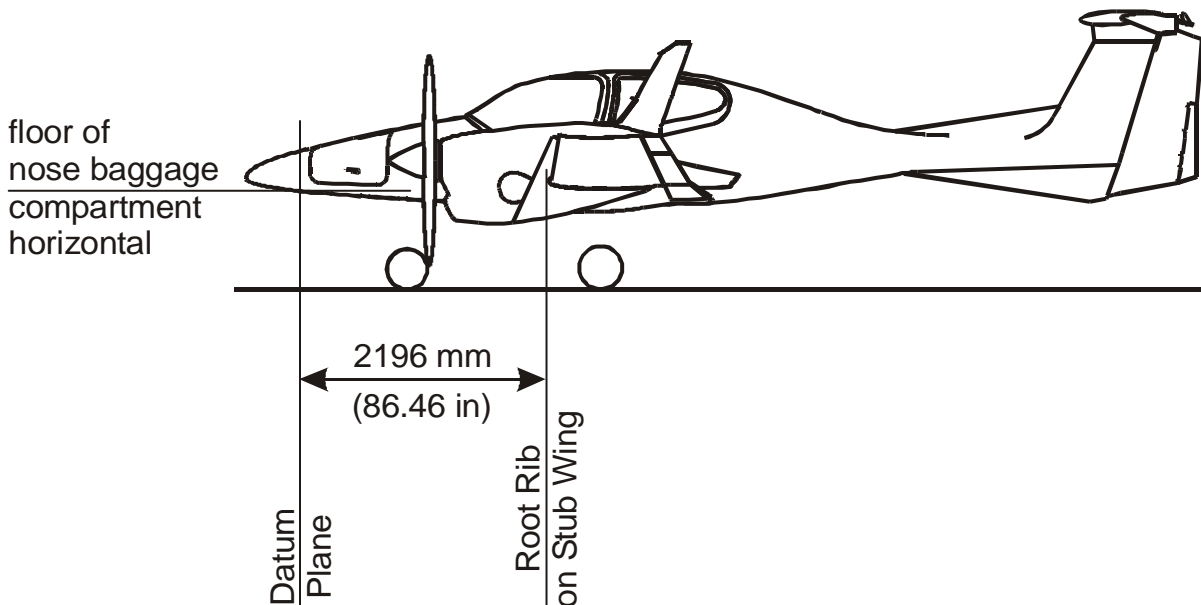

6.3 MASS AND BALANCE REPORT

The empty mass and the corresponding CG position established before delivery are the first entries in the Mass and Balance Report. Every change in permanently installed equipment, and every repair to the airplane which affects the empty mass or the empty mass CG must be recorded in the Mass and Balance Report.

For the calculation of flight mass and corresponding CG position (or moment), the *current* empty mass and the corresponding CG position (or moment) in accordance with the Mass and Balance Report must always be used.

Condition of the airplane for establishing the empty mass:

- Equipment as per Equipment Inventory (see Section 6.5)
- Including the following full operating fluids:
 - brake fluid
 - hydraulic fluid (for the retractable gear)
 - engine oil (2 x 7 liters = 2 x 7.4 qts)
 - coolant
 - gearbox oil
 - unusable fuel in main fuel tanks (2 x 1 US gal = 2 x 3.79 liters)
 - unusable fuel in auxiliary fuel tanks (if installed, 2 x 0.5 US gal = 2 x 1.89 liters)

6.4 FLIGHT MASS AND CENTER OF GRAVITY

The following information enables you to operate your DA 42 NG within the permissible mass and balance limits. For the calculation of the flight mass and the corresponding CG position the following tables and diagrams are required:

- 6.4.1 - MOMENT ARMS
- 6.4.2 - LOADING DIAGRAM
- 6.4.3 - CALCULATION OF LOADING CONDITION
- 6.4.4 - PERMISSIBLE CENTER OF GRAVITY RANGE
- 6.4.5 - PERMISSIBLE MOMENT RANGE

The diagrams should be used as follows:

1. Take the empty mass and the empty mass moment of your airplane from the Mass and Balance Report, and enter the figures in the appropriate boxes under the column marked 'Your DA 42 NG' in Table 6.4.3 - CALCULATION OF LOADING CONDITION.
2. Read the fuel quantity indicators to determine the fuel quantity in the main fuel tanks.
3. Determine the fuel quantity in the auxiliary fuel tanks (if installed).

To verify an empty auxiliary fuel tank, set the ELECT. MASTER switch and the AUX PUMP switch to ON and check the PFD for the L/R AUX FUEL E caution message.

To verify a full auxiliary fuel tank open the auxiliary fuel tank filler and check fuel level.

If the auxiliary fuel tank quantity is in between empty and full, the exact quantity cannot be determined. If possible transfer all fuel to the main fuel tank by setting the ELECT. MASTER switch and the AUX PUMP switch to ON until the L/R AUX FUEL E caution message appears on the PFD. During this procedure ground power must be used or at least one engine must be running. The fuel transfer will take a maximum of 10 minutes.

CAUTION

If the auxiliary tanks are in use, both tanks must be refueled to the maximum level to provide proper information for the pilot about the fuel quantity in the auxiliary fuel tanks.

If the auxiliary tanks are not in use, the pilot must ensure that they are empty.

4. Multiply the individual masses by the moment arms quoted to obtain the moment for every item of loading and enter these moments in the appropriate boxes in Table 6.4.3 - CALCULATION OF LOADING CONDITION.
5. Add up the masses and moments in the respective columns. The CG position is calculated by dividing the total moment by the total mass (using row 11 for the condition with empty fuel tanks, and row 14 for the pre take-off condition). The resulting CG position must be inside the limits.

As an illustration the total mass and the CG position are entered on Diagram 6.4.4 - PERMISSIBLE CENTER OF GRAVITY RANGE. This checks graphically that the current configuration of the airplane is within the permissible range.

6. Graphical method:

Diagram 6.4.2 - LOADING DIAGRAM is used to determine the moments. The masses and moments for the individual items of loading are added. Then Diagram 6.4.5 - PERMISSIBLE MOMENT RANGE is used to check whether the total moment associated with the total mass is in the permissible range.

The result found with the graphical method is however inaccurate. In doubtful cases the result must be verified using the exact method given above.

6.4.1 MOMENT ARMS

The most important lever arms aft of the Datum Plane:

Item		Lever Arm	
		[m]	[in]
Occupants on front seats		2.30	90.6
Occupants on rear seats		3.25	128.0
Fuel	in main tanks	2.63	103.5
	in auxiliary tanks (if installed)	3.20	126.0
De-icing fluid	Tank in nose baggage compartment (if only OÄM 42-160 installed)	1.00	39.4
	Tank in rear fuselage (if OÄM 42-160 AND OÄM 42-203 are installed)	4.52	178.0

Item		Lever Arm	
		[m]	[in]
Baggage in compartments	Standard:		
	Nose	0.60	23.6
	Cabin	3.89	153.1
	Extension	4.54	178.7
	OÄM 42-207 carried out:		
	Standard baggage compartment	3.65	143.7
	Short extension	3.97	156.3

6.4.2 LOADING DIAGRAM

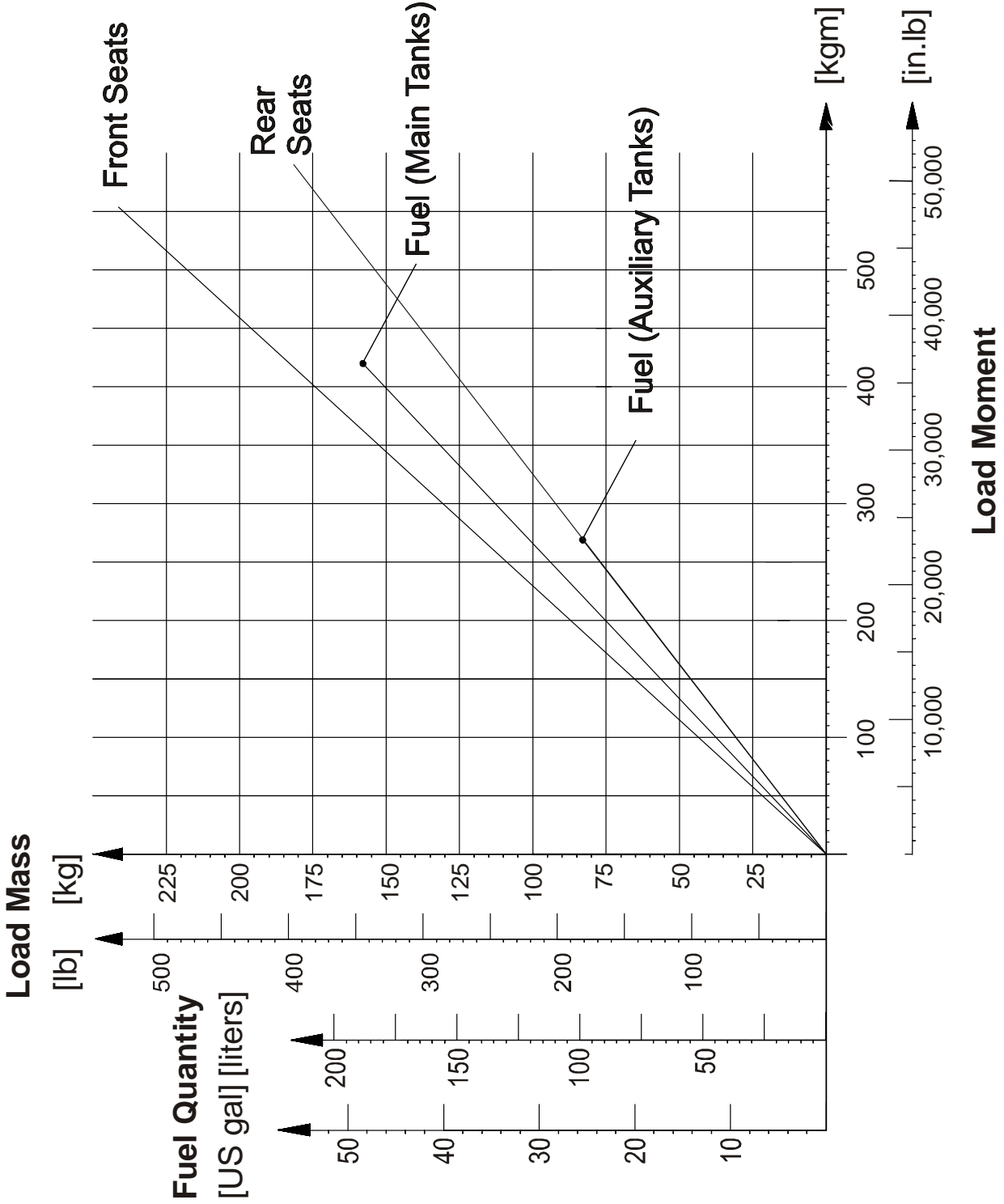

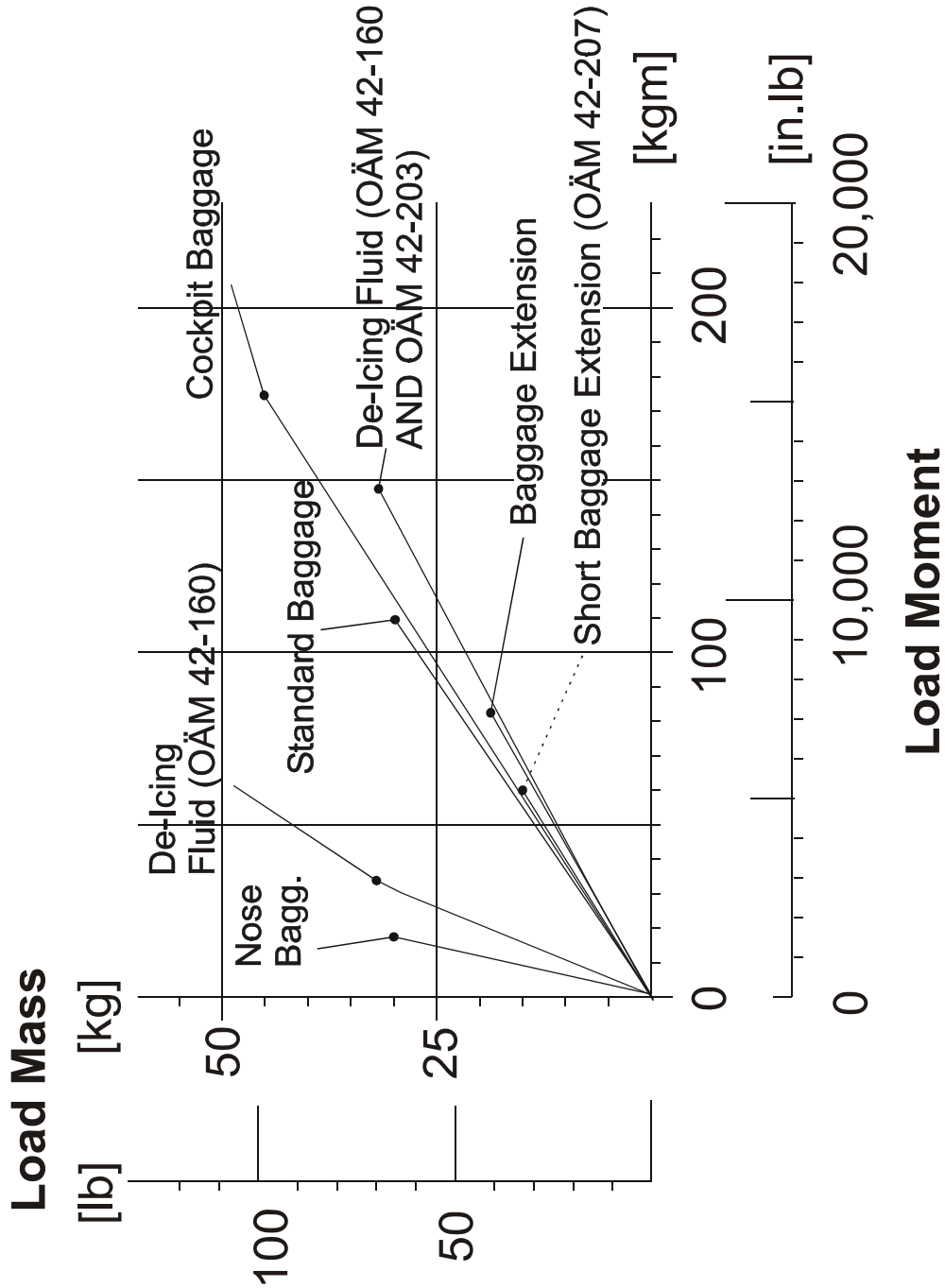

6.4.3 CALCULATION OF LOADING CONDITION

NOTE

It the optional de-icing system OÄM 42-160 is installed, the following must be observed:

The consumption of fuel causes a forward movement of the CG. The consumption of the de-icing fluid causes a rearward movement of the CG (if only OÄM 42-160 is installed) or a forward movement of the CG (if OÄM 42-203 is installed additionally). Depending on the fuel flow and de-icing fluid flow, the overall movement of the CG can be a forward or a rearward movement. In order to cover all possible cases, the following table must be completed twice: with (as shown in the example) and without considering the on-board de-icing fluid. All four CG positions (fuel tank full/empty, de-icing fluid tank full/empty) must fall into the permitted area.

1. Complete the form on the next page.
2. Divide the total moments from rows 11 and 14 by the related total mass to obtain the CG positions.

In our example:

empty tanks:	$3958.7 \text{ kgm} / 1655.5 \text{ kg} = 2.391 \text{ m}$
	$343,717 \text{ in.lb} / 3651.0 \text{ lb} = 94.14 \text{ in}$
full tanks:	$4645.7 \text{ kgm} / 1898.5 \text{ kg} = 2.447 \text{ m}$
	$403,356 \text{ in.lb} / 4187.0 \text{ lb} = 96.335 \text{ in}$

3. Locate the values in the diagram in Section 6.4.4 - PERMISSIBLE CENTER OF GRAVITY RANGE. If the CG positions and related masses fall into the permitted area, the loading condition is allowable.

Our example shows allowable loading conditions.

CALCULATION OF LOADING CONDITION	DA 42 NG (Example)		Your DA 42 NG	
	Mass [kg] [lb]	Moment [kgm] [in.lb]	Mass [kg] [lb]	Moment [kgm] [in.lb]
1. Empty mass (from Mass and Balance Report)	1450 3197	3488.0 302,747		
2. Front seats Lever arm: 2.30 m (90.6 in)	160 353	368.0 31,982		
3. Rear seats Lever arm: 3.25 m (128.0 in)	0 0	0.0 0,0		
4. Nose baggage compt. Lever arm: 0.60 m (23.6 in)	0 0	0.0 0,0		
5. Cabin baggage compt. Lever arm: 3.89 m (153.1 in)	10 22	38.9 3,368		
6. Baggage extension Lever arm: 4.54 m (178.7 in)	8 18	36.3 3,217		
7. Standard baggage compartment Lever arm: 3.65 m (143.7 in)	0 0	0.0 0,0		
8. Short baggage extension (if OÄM 42-207 is carried out) Lever arm: 3.97 m (156.3 in)	0 0	0.0 0,0		
9. De-icing fluid (if only OÄM 42-160 is installed; see NOTE on previous page) (1.1 kg/liter) (9.2 lb/US gal) Lever arm: 1.00 m (39.4 in)	27.5 61	27.5 2,403		

CALCULATION OF LOADING CONDITION	DA 42 NG (Example)		Your DA 42 NG	
	Mass [kg] [lb]	Moment [kgm] [in.lb]	Mass [kg] [lb]	Moment [kgm] [in.lb]
10. De-icing fluid (if OÄM 42-160 AND OÄM 42-203 are installed; see NOTE on previous page) (1.1 kg/liter) (9.2 lb/US gal) Lever arm: 4.52 m (178.0 in)	0 0	0.0 0,0		
11. Total mass & total moment with empty fuel tanks (Total of 1.through 10.)	1655.5 3651	3958.7 343,717		
12. Usable fuel, main tanks (0.84 kg/liter) (7.01 lb/US gal) Lever arm: 2.63 m (103.5 in)	159 351	418.2 36,329		
13. Usable fuel, auxiliary tanks (if installed) (0.84 kg/liter) (7.01 lb/US gal) Lever arm: 3.20 m (126.0 in)	84 185	268.8 23,310		
14. Total mass & total moment with fuel & de-icing fluid (Total of 11. through 13.)	1898.5 4187	4645.7 403,356		

The CG's shown in the following diagrams are those from the example in Section 6.4.3 - CALCULATION OF LOADING CONDITION, rows 11 and 14.

6.4.4 PERMISSIBLE CENTER OF GRAVITY RANGE

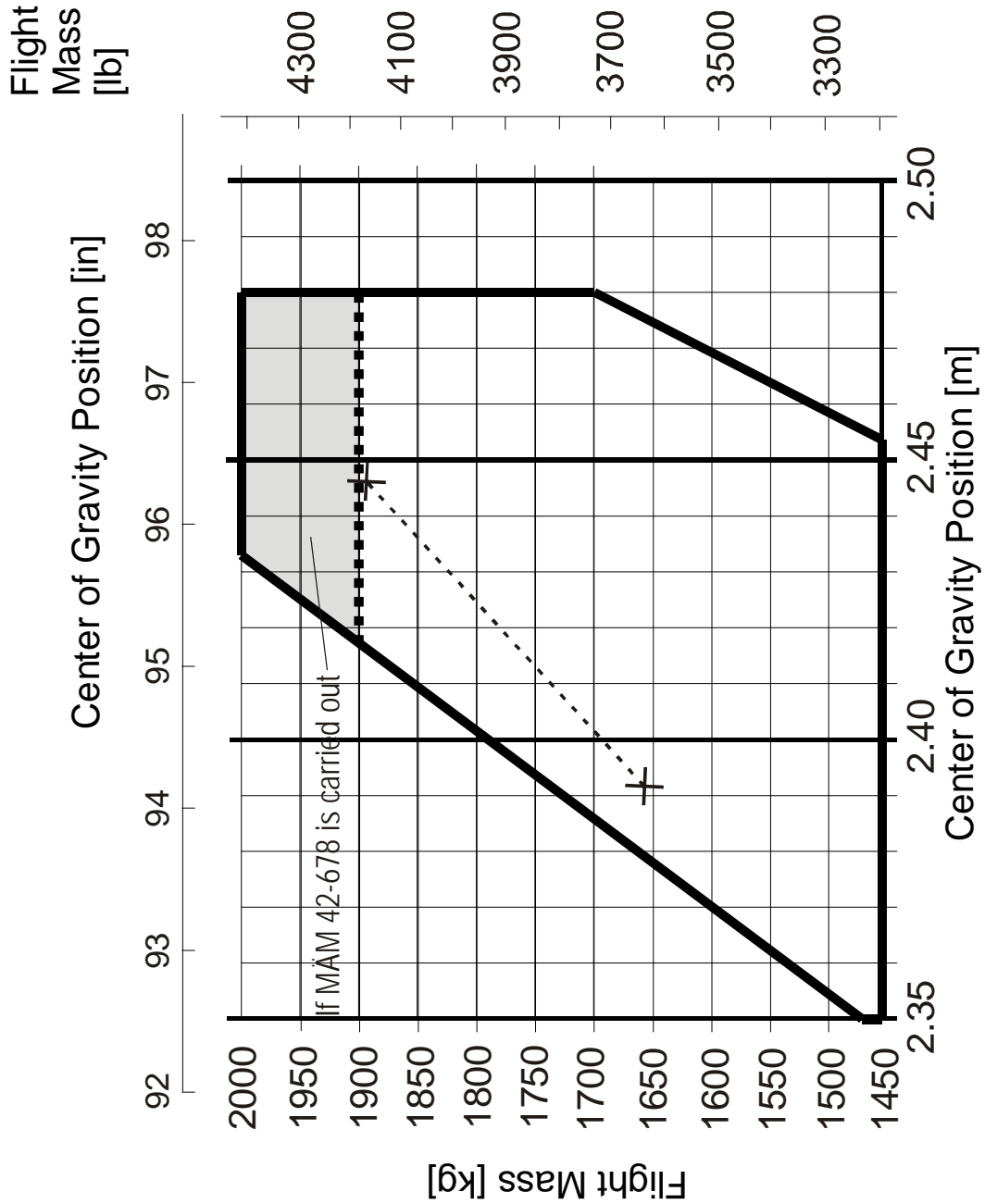

The flight CG position must be within the following limits:

Most forward flight CG:

2.350 m (92.52 in) aft of datum plane at 1450 kg (3197 lb)

2.350 m (92.52 in) aft of datum plane at 1468 kg (3236 lb)

2.418 m (95.20 in) aft of datum plane at max. take-off mass 1900 kg (4189 lb)

If MÄM 42-678 is carried out:

2.434 m (95.83 in) aft of datum plane at max. take-off mass 1999 kg (4407 lb)

linear variation in between

Most rearward flight CG:

2.454 m (96.61 in) aft of datum plane at 1450 kg (3197 lb)

2.480 m (97.64 in) aft of datum plane at 1700 kg (3748 lb)

2.480 m (97.64 in) aft of datum plane at max. take-off mass (see Section 2.7)

linear variation in between

6.4.5 PERMISSIBLE MOMENT RANGE

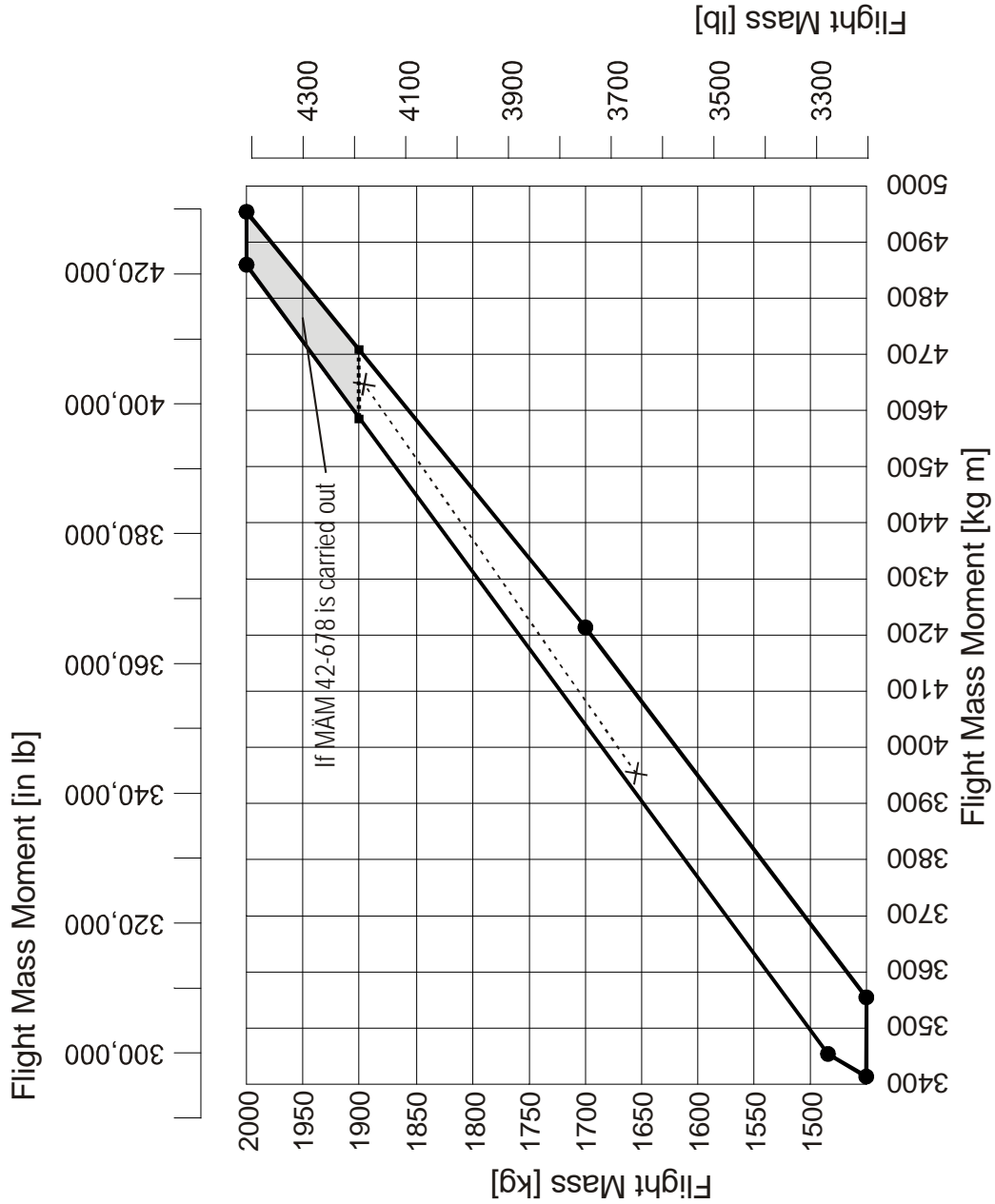

The flight mass moments shown in the diagram are those from the example in Table 6.4.3 (a) - CALCULATION OF LOADING CONDITION, rows 11 and 14.

6.5 EQUIPMENT LIST AND EQUIPMENT INVENTORY

All equipment that is approved for installation in the DA 42 NG is shown in the *Equipment List* below.

NOTE

The equipment listed below cannot be installed in any arbitrary combination. The airplane manufacturer must be contacted before removing or installing equipment, with the exception of replacing a unit by an identical unit.

The items of equipment installed in your particular airplane are indicated in the appropriate column. The set of items marked as 'installed' constitutes the *Equipment Inventory*.

Airplane Serial No.:		Registration:		Date:		Mass		Lever Arm	
Description	Type	Part No.	Manufacturer	S/N	Installed	lb	kg	in	m
<i>AVIONICS COOLING</i>									
Avionics cooling fan	SAFE 328	305 467-00	Sandia Aerospace						
PFD cooling fan	SAFE 128	305 468-00	Sandia Aerospace						
MFD cooling fan	SAFE 128	305 468-00	Sandia Aerospace						
<i>AUTOPILOT SYSTEM</i>									
Pitch servo	GSA 81	011-00878-00	Garmin						
Pitch servo	GSA 81	011-00878-20	Garmin						
Pitch servo mount	GSM 85	011-00894-07	Garmin						
Pitch servo mount	GSM 86	011-01904-03	Garmin						
Pitch clutch cartridge		011-02147-11	Garmin						
Roll servo	GSA 81	011-00878-00	Garmin						
Roll servo	GSA 81	011-00878-20	Garmin						
Roll servo mount	GSM 85	011-00894-07	Garmin						
Roll servo mount	GSM 86	011-01904-03	Garmin						
Roll clutch cartridge		011-02147-09	Garmin						
Pitch trim servo	GSA 81	011-00878-00	Garmin						
Pitch trim servo	GSA 81	011-00878-20	Garmin						
Pitch trim servo mount	GSM 85	011-00894-04	Garmin						
Pitch trim servo mount	GSM 86	011-01904-03	Garmin						
Pitch trim clutch cartridge		011-02147-09	Garmin						
Yaw servo	GSA 80	011-00877-00	Garmin						
Yaw servo	GSA 80	011-00877-20	Garmin						
Yaw servo mount	GSM 85	011-00894-08	Garmin						
Yaw servo mount	GSM 86	011-01904-03	Garmin						

Airplane Serial No.:		Registration:		Date:		Mass		Lever Arm	
Description	Type	Part No.	Manufacturer	S/N	Installed	lb	kg	in	m
Yaw clutch cartridge		011-02147-03	Garmin						
Control stick		DA4-2213-12-90	Diamond Aircraft						
CWS switch		031-00514-0000	Bendix/King						
AP-disc switch		031-00428-0000	Bendix/King						
Trim switch assy		200-09187-0000	Bendix/King						
ELECTRICAL POWER									
Main battery	RG24-15(M)		Concorde						
Emergency battery		D60-2560-91-00	Diamond Aircraft						
Emergency battery (10 pcs.)	CR 123 A		Panasonic						
ECU backup battery LH (2 pcs.)	LC-R127R2P		Panasonic						
ECU backup battery RH (2 pcs.)	LC-R127R2P		Panasonic						
ECU backup battery RH (2 pcs.)	LC-RA1212P()1		Panasonic						
ECU backup battery LH (2 pcs.)	NP7-12		Yuasa						
ECU backup battery RH (2 pcs.)	NP7-12		Yuasa						
ECU backup battery RH (2 pcs.)	NP12-12		Yuasa						
External power connector		DA4-2443-10-00	Diamond Aircraft						
Additional Alternator		ES-10024B-2	Kelly Aerospace						
Alternator Pulley		D44-2416-00-34X01	Diamond Aircraft						
Gear Box Fan Assy		D44-2416-20-00	Diamond Aircraft						
Prop. Flange Pulley Support		D44-2416-00-52_1	Diamond Aircraft						
Additional Alternator V-belt		ISO 4184 XPZ	Diamond Aircraft						
Additional Alternator Regulator		VR2000-28-1	Electrosystems Inc.						
USB Charging Port (2 pcs.)	TA 202	6430202-9	True Blue Power						

Airplane Serial No.:		Registration:		Date:		Mass		Lever Arm	
Description	Type	Part No.	Manufacturer	S/N	Installed	lb	kg	in	m
<i>EQUIPMENT</i>									
Safety belt, pilot	5-01-() Series	5-01-1C0710	Schroth			2.110	0.960	92.520	2.350
Safety belt, co-pilot	5-01-() Series	5-01-1C5710	Schroth			2.110	0.960	92.520	2.350
Safety belt, LH pax	5-01-() Series	5-01-1B5710	Schroth			2.250	1.020	126.800	3.220
Safety belt, RH pax	5-01-() Series	5-01-1B0710	Schroth			2.250	1.020	126.800	3.220
Safety belt, pilot	5-01-() Series	5-01-2G0710	Schroth			2.110	0.960	92.520	2.350
Safety belt, co-pilot	5-01-() Series	5-01-2G5710	Schroth			2.110	0.960	92.520	2.350
Safety belt, LH pax	5-01-() Series	5-01-2H5710	Schroth			2.250	1.020	126.800	3.220
Safety belt, RH pax	5-01-() Series	5-01-2H0710	Schroth			2.250	1.020	126.800	3.220
Safety belt, pilot	5-01-() Series	5-01-2G0701	Schroth			2.110	0.960	92.520	2.350
Safety belt, co-pilot	5-01-() Series	5-01-2G5701	Schroth			2.110	0.960	92.520	2.350
Safety belt, LH pax	5-01-() Series	5-01-2H5701	Schroth			2.250	1.020	126.800	3.220
Safety belt, RH pax	5-01-() Series	5-01-2H0701	Schroth			2.250	1.020	126.800	3.220
ELT unit	ME406	453-6603	Artex			2.064	0.936	179.700	4.565
ELT unit	C406-1	453-5002	Artex			2.064	0.936	179.700	4.565
ELT remote switch		345-6196-04	Artex						
ELT antenna		110-338	Artex			0.470	0.213	152.800	3.880
ELT unit	406 AF-Compact	S1840501-01	Kannad			1.874	0.874	179.700	4.565
ELT unit	AF-Integra	S185150102	Kannad						
ELT remote switch	RC 200	S1820513-11	Kannad						
ELT antenna	ANT300	0124220	Kannad			0.330	0.150	152.800	3.880
ELT antenna	AV-300	0146151	Kannad			0.330	0.150	152.800	3.880
Buzzer		452-6505	Artex						

Airplane Serial No.:		Registration:		Date:		Mass		Lever Arm	
Description	Type	Part No.	Manufacturer	S/N	Installed	lb	kg	in	m
SAFETY EQUIPMENT									
Fire extinguisher		HAL 1	AIR Total						
Fire extinguisher, portable ¹		A 620 T	Amerex						
First aid kit									
Emergency axe		G45912	Fiskars						
Emergency egress hammer		D67-2560-80-50	Diamond						
Emergency egress hammer		D64-2560-70-50	Diamond						
FLIGHT CONTROLS									
Flaps actuator assy		43055	Krutz						
Lift detector		C-99701-1	Safe Flight Instr.						
Stall warning buzzer	SC Series	SC 628 ND	Mallory						
Variable elevator stop		D64-2733-12-00	Diamond Aircraft						
Variable elevator stop		D64-2733-12-00_1	Diamond Aircraft						
HYDRAULIC									
Motor pump unit		X11-0001-00-00.00R0	Hydraulik Mayer						
Hydraulic fluid tank		X11-0002-00-00.00R0	Hydraulik Mayer						
Hydraulic control unit		X11-0003-00-00.00R0	Hydraulik Mayer						
High pressure filter		X11-0004-00-00.00R0	Hydraulik Mayer						
Hydraulic pressure accumulator		X11-0005-00-00.00R0	Hydraulik Mayer						
MLG hydraulic cylinder, LH		X11-0006-00-00.00/1R0	Hydraulik Mayer						
MLG hydraulic cylinder, RH		X11-0006-00-00.00/1R0	Hydraulik Mayer						
NLG hydraulic cylinder		X11-0006-00-00.00/2R0	Hydraulik Mayer						

Airplane Serial No.:		Registration:		Date:		Mass		Lever Arm	
Description	Type	Part No.	Manufacturer	S/N	Installed	lb	kg	in	m
NLG hydraulic cylinder		X11-0006-00-0000/2A	Hydraulik Mayer						
NLG hydraulic cylinder		D60-9029-03-01_1	Hydraulik Mayer						
NLG hydraulic cylinder		D60-9029-03-01_2	Hydraulik Mayer						
Brake master cylinder (2 pcs.)		10-54A	Cleveland						
Parking valve		60-5D	Cleveland						
Brake assembly		30-52Z	Cleveland						
INDICATING / REC. SYSTEM									
Primary flight display (PFD)	GDU 1040	011-00972-03	Garmin			6.400	2.900	70.080	1.780
Multi function display (MFD)	GDU 1045	011-00819-04	Garmin			6.400	2.900	70.080	1.780
Primary flight display (PFD)	GDU 1040	011-00972-10	Garmin			6.400	2.900	70.080	1.780
Multi function display (MFD)	GDU 1045	011-00819-10	Garmin			6.400	2.900	70.080	1.780
Primary flight display (PFD)	GDU 1040	011-00972-02	Garmin			6.400	2.910	70.080	1.780
Primary flight display (PFD)	GDU 1050	011-03470-00	Garmin			4.700	2.130	70.080	1.780
Multi function display (MFD)	GDU 1055	011-03470-80	Garmin			4.700	2.130	70.080	1.780
Chronometer		09CH	Adriatica						
LANDING GEAR									
Main landing gear LH		D64-3217-11-00	Diamond Aircraft						
Main landing gear RH		D64-3217-12-00	Diamond Aircraft						
Nose landing gear		D64-3223-00-00_1	Diamond Aircraft						
Nose landing gear		D64-3223-00-00_2	Diamond Aircraft						

Airplane Serial No.:		Registration:		Date:		Mass		Lever Arm	
Description	Type	Part No.	Manufacturer	S/N	Installed	lb	kg	in	m
Nose landing gear		D64-3223-00-00_04	Diamond Aircraft						
LDG gear warning	SC Series	SC 628 NDP	Mallory						
Main landing gear LH		D64-3217-11-00_04	Diamond Aircraft						
Main landing gear RH		D64-3217-12-00_04	Diamond Aircraft						
Nose landing gear		D64-3223-10-00_04	Diamond Aircraft						
LIGHTS									
Map / Reading light assy crew		W1461.0.010	Rivoret						
Map / Reading Light		RL6980-1	Birk Aerosystems						
Map Light Assy		D60-3313-11-00-_01	Diamond Aircraft						
Cabin Light		W1461.0.010	Rivoret						
Strobe / Pos. light assy LH	A600-PR-D-28	01-0790006-05	Whelen			0.800	0.363	103.800	2.638
Strobe / Pos. light assy RH	A600-PG-D-28	01-0790006-07	Whelen			0.800	0.363	103.800	2.638
Strobe / Pos. light assy LH	OR6002R	01-0771733-12	Whelen			0.400	0.181	103.800	2.638
Strobe / Pos. light assy RH	OR6002G	01-0771733-11	Whelen			0.400	0.181	103.800	2.638
Strobe light power supply LH/RH	A490ATS-CF-14/28	01-0770062-05	Whelen						
Taxi light	Xenon D1S		Aero Vision Int.			0.990	0.449	79.920	2.030
Taxi light power supply	XV1-28		Aero Vision Int.			0.880	0.400	82.290	2.090
Landing light	Xenon D1S		Aero Vision Int.			0.990	0.449	79.920	2.030
Landing light power supply	XV1-28		Aero Vision Int.			0.880	0.400	82.290	2090
Taxi light power supply		XV4D-35	XeVision						
Landing light power supply		XV4D-35	XeVision						
Glareshield lamp assy		DA4-3311-10-02	Diamond Aircraft						
Glareshield light inverter		APVL328-4-1-L-5QF	Quantaflex						

Airplane Serial No.:		Registration:		Date:		Mass		Lever Arm	
Description	Type	Part No.	Manufacturer	S/N	Installed	lb	kg	in	m
Placards inverter		APVL328-4-1-L-15QF	Quantaflex						
<i>COMMUNICATION / NAVIGATION</i>									
COMM #1 antenna	DMC63-1/A		DM			0.400	0.180	177.100	4.500
COMM #2 antenna	DMC63-2		DM			0.400	0.180	155.100	3.940
COMM #1 antenna	CI 291		Comant			0.500	0.227	177.160	4.500
COMM #2 antenna	CI 292-2		Comant			0.500	0.227	161.420	4.100
Audio panel / Marker / ICS	GMA 1347	011-00809-00	Garmin						
Audio panel / Marker / ICS	GMA 1360	011-03568-00	Garmin						
Headset, pilot	Echelon 100		Telex						
Headset, pilot	HMEC25-KAP-2	025-230-715	Sennheiser						
Headset, co-pilot	Echelon 100		Telex						
Headset, co-pilot	HMEC25-KAP-2	025-230-715	Sennheiser						
Headset, LH pax	Echelon 100		Telex						
Headset, LH pax	HMEC25-KAP-2	025-230-715	Sennheiser						
Headset, RH pax	Echelon 100		Telex						
Headset, RH pax	HMEC25-KAP-2	025-230-715	Sennheiser						
Speaker	FRS8 / 4 Ohms		Visaton						
Handmic	100 TRA	62800-001	Telex						
Pitot / Static probe, heated	AN5814-2	PST-305	Aeroinstruments						
Alternate static valve		DA4-3111-51-00	Diamond Aircraft						
Backup altimeter		5934PD-3	United Instruments			0.496	0.225	70.080	1.780
Backup altimeter	LUN 1120	1120.23B2X	Mikrotechna						
Backup altimeter	LUN 1128	1128.10B6	Mikrotechna						

Airplane Serial No.:		Registration:		Date:		Mass		Lever Arm	
Description	Type	Part No.	Manufacturer	S/N	Installed	lb	kg	in	m
Backup airspeed indicator	8030	8030-B.879	United Instruments			0.680	0.308	70.080	1.780
Backup airspeed indicator	8030	8030-B.910	United Instruments			0.680	0.308	70.080	1.780
Backup artificial horizon	4300	4300-206	Mid Continent Instr.			2.500	1.134	70.080	1.780
Backup artificial horizon	LUN 1241	1241.G8D0R	Mikrotechna						
Standby Attitude Module	MD302	6420302-2	Mid Continent Instr.			1.600	0.730	70.08	1.78
Magnetic compass		PG2C-28V	SIRS Navigation						
Magnetic compass		NV2S-2400-28V	SIRS Navigation						
OAT probe	GTP 59	011-00978-00	Garmin						
Digital air data system	GDC74A	011-00882-00	Garmin			1.690	0.770	70.080	1.780
Digital air data system	GDC 74A	011-00882-10	Garmin			1.690	0.770	70.080	1.780
Digital air data system	GDC 72	011-03734-00	Garmin			1.260	0.570	70.080	1.780
Integrated avionics #1	GIA 63 W	011-01105-20	Garmin			5.290	2.400	154.900	3.935
Integrated avionics #2	GIA 63 W	011-01105-20	Garmin			5.290	2.400	154.900	3.935
Integrated avionics #1	GIA 63W	011-01105-01	Garmin			5.290	2.400	154.900	3.935
Integrated avionics #2	GIA 63W	011-01105-01	Garmin			5.290	2.400	154.900	3.935
Integrated avionics #1	GIA 63	011-00781-01	Garmin			5.290	2.400	154.900	3.935
Integrated avionics #2	GIA 63	011-00781-01	Garmin			5.290	2.400	154.900	3.935
Integrated avionics #1	GIA 64W	011-03711-00	Garmin			5.400	2.450	154.900	3.935
Integrated avionics #2	GIA 64W	011-03711-00	Garmin			5.400	2.450	154.900	3.935
Transponder	GTX 33	011-00779-10	Garmin			3.100	1.410	153.100	3.890
Transponder	GTX 33	011-00779-00	Garmin			3.030	1.380	153.100	3.890
Transponder	GTX 335 R	011-03301-00	Garmin			1.900	0.860	153.100	3.890
Transponder	GTX 33 ES	011-00779-30	Garmin			3.100	1.410	153.100	3.890
Transponder	GTX 345R	011-03303-00	Garmin			2.200	1.000	153.100	3.890
Attitude / Heading reference system	GRS 77	011-00868-10	Garmin			2.800	1.270	154.900	3.935
Attitude / Heading reference system	GRS 77	011-00868-00	Garmin			2.540	1.150	154.900	3.935

Airplane Serial No.:		Registration:		Date:		Mass		Lever Arm	
Description	Type	Part No.	Manufacturer	S/N	Installed	lb	kg	in	m
Attitude / Heading reference system	GRS 79	011-03732-00	Garmin			1.080	0.490	154.900	3.935
Magnetometer	GMU 44	011-00870-00	Garmin			0.350	0.160	103.800	2.638
Magnetometer	GMU 44	011-00870-10	Garmin			0.350	0.160	103.800	2.638
VOR / LOC / GS antenna	CI 157P		Comant						
Dual VOR / dual GS duplexer	CI 1125		Comant						
LH: VOR / LOC / GS antenna	CI120-1		Comant						
RH: VOR / LOC / GS antenna	CI120-1		Comant						
VOR / LOC / GS PWR combiner	CI120-3		Comant						
Transponder antenna	KA 61	071-00221-0010	Bendix/King						
Marker antenna	CI 102		Comant						
GPS #1 antenna	GA 36	013-00244-00	Garmin			0.470	0.210	104.100	2.645
GPS #2 antenna	GA 36	013-00244-00	Garmin			0.470	0.210	104.100	2.645
DME	KN 63	066-1070-01	Bendix/King			2.800	1.270	141.100	3.580
DME antenna	KA 61	071-00221-0010	Bendix/King						
Transponder antenna	KA 60	071-01591-0001	Bendix/King			0.220	0.100	91.930	2.335
Transponder antenna	CI 105-16		Comant			0.200	0.091	91.930	2.335
GPS #1 antenna	GA 56	010-10040-01	Garmin			0.400	0.180	104.100	2.645
GPS #2 antenna	GA 56	010-10040-01	Garmin			0.400	0.180	104.100	2.645
DME antenna	KA 60	071-01591-0001	Bendix/King			0.220	0.100	91.930	2.335
DME antenna	CI 105-16		Comant			0.200	0.091	91.930	2.335
ADF receiver	RA 3502-(01)	0505.757-912	Becker			2.200	1.000	155.500	3.950
ADF / RMI converter	AC 3504-(01)	0856.010-912	Becker			1.650	0.750	165.400	4.200
ADF antenna	AN 3500	0832.601-912	Becker			0.375	0.170	133.900	3.400
Stormscope	WX-500	805-11500-001	L-3 (Goodrich)			2.500	1.130	140.100	3.560
Stormscope antenna	NY-163	805-10930-001	L-3 (Goodrich)			0.840	0.380	280.700	7.130
Weather radar	GWX 68	011-00883-00	Garmin			9.000	4.080	-2.362	-0.060

Airplane Serial No.:		Registration:		Date:		Mass		Lever Arm	
Description	Type	Part No.	Manufacturer	S/N	Installed	lb	kg	in	m
Weather radar	GWX 70	011-01768-00	Garmin						
Weather radar antenna		117-00254-00	Garmin						
Radome		D64-5340-65-00	Diamond Aircraft						
TAS processor	TAS 600	70-2420-x TAS600	Avidyne/Ryan			6.800	3.100	164.300	4.175
TAS processor	TAS 605	70-2420-x TAS605	Avidyne/Ryan			6.800	3.100	164.300	4.175
TAS processor	TAS 610	70-2420-x TAS610	Avidyne/Ryan			6.800	3.100	164.300	4.175
TAS processor	TAS 615	70-2420-x TAS615	Avidyne/Ryan			6.800	3.100	164.300	4.175
TAS processor	TAS 620	70-2420-x TAS620	Avidyne/Ryan			6.800	3.100	164.300	4.175
TAS processor	9900BX	70-2420-x	Avidyne/Ryan			6.800	3.100	164.300	4.175
TAS processor	TAS 600A	700-00185-000	Avidyne			6.800	3.100	164.300	4.175
TAS processor	TAS 605A	700-00185-001	Avidyne			6.800	3.100	164.300	4.175
TAS processor	TAS 610A	700-00185-002	Avidyne			6.800	3.100	164.300	4.175
TAS processor	TAS 615A	700-00185-003	Avidyne			6.800	3.100	164.300	4.175
TAS processor	TAS 620A	700-00185-004	Avidyne			6.800	3.100	164.300	4.175
Transponder coupler		70-2040	Avidyne/Ryan			0.500	0.230	197.600	5.020
TAS antenna, top		S72-1750-31L	Sensor Systems			0.660	0.298	164.800	4.188
TAS antenna, bottom		S72-1750-32L	Sensor Systems			0.750	0.340	104.300	2.650
EMI filter LH		D64-3454-10-00	Diamond Aircraft						
EMI filter RH		D64-3454-10-00	Diamond Aircraft						
Satellite Transceiver	GSR 56	011-02268-00	Garmin						
Iridium antenna	CI 490-1		Comant						
Iridium antenna	CI 490-490		Comant						
Flight Stream 510		011-03595-00	Garmin						

Airplane Serial No.:		Registration:		Date:		Mass		Lever Arm	
Description	Type	Part No.	Manufacturer	S/N	Installed	lb	kg	in	m
<i>OXYGEN SYSTEM</i>									
Oxygen cylinder (empty)		1270152-2	Aerox			7.400	3.357	32.280	0.820
Oxygen cylinder (empty)		4110-200-2	Aerox			7.400	3.357	32.280	0.820
Single outlet manifold LH		4110-401-2	Aerox			0.230	0.104	69.690	1.770
Single outlet manifold LH		4110-401-2-01	Aerox			0.230	0.104	69.690	1.770
Single outlet manifold RH		4110-401-2	Aerox			0.230	0.104	69.690	1.770
Single outlet manifold RH		4110-401-2-01	Aerox			0.230	0.104	69.690	1.770
Dual outlet manifold		4110-400-2	Aerox			0.420	0.191	109.300	2.775
Oxygen pressure regulator		4110-110	Aerox			0.740	0.336	21.260	0.540
Oxygen pressure regulator		4110-140-2	Aerox			0.740	0.336	21.260	0.540
Filling block		4110-405	Aerox			0.540	0.245	28.150	0.715
Pressure gauge		4110-490	Aerox			0.110	0.050	70.080	1.780
Pressure gauge		4110-486	Aerox			0.110	0.050	70.080	1.780
<i>ENGINE</i>									
LH engine	E4	E4-C	Austro Engine						
RH engine	E4	E4-C	Austro Engine						
LH engine control unit	EECU-E4-01	E4A-92-100-000	Austro Engine						
RH engine control unit	EECU-E4-01	E4A-92-100-000	Austro Engine						
ECU software		Refer to DAI Service Bulletin MSB-42NG-002	Austro Engine						
Engine airframe unit	GEA 71B	011-03682-00	Garmin						
<i>ENGINE STARTING</i>									
Glow plug control unit LH/RH		E4A-94-200-000	Austro Engine						

Airplane Serial No.:		Registration:		Date:		Mass		Lever Arm	
Description	Type	Part No.	Manufacturer	S/N	Installed	lb	kg	in	m
Starter LH / RH		E4A-93-000-000	Austro Engine						
<i>ELECTRICAL POWER</i>									
LH alternator		E4A-91-000-000	Austro Engine						
RH alternator		E4A-91-000-000	Austro Engine						
LH alternator		E4A-91-400-000	Austro Engine						
RH alternator		E4A-91-400-000	Austro Engine						
LH alternator regulator		E4A-91-200-000	Austro Engine						
RH alternator regulator		E4A-91-200-000	Austro Engine						
<i>ENGINE FUEL PUMPS</i>									
LH fuel pumps (2x)		0-580-054-001	Bosch						
RH fuel pumps (2x)		0-580-054-001	Bosch						
<i>ENGINE FIRE WARNING</i>									
LH overheat detector		X 2003-2	Control Products, Inc.						
RH overheat detector		X 2003-2	Control Products, Inc.						
LH overheat detector		X 2003-506	Control Products, Inc.						
RH overheat detector		X 2003-506	Control Products, Inc.						
<i>ENGINE INDICATING</i>									
Engine / Airframe unit	GEA 71	011-00831-00	Garmin						

Airplane Serial No.:		Registration:		Date:		Mass		Lever Arm	
Description	Type	Part No.	Manufacturer	S/N	Installed	lb	kg	in	m
<i>ENGINE EXHAUST</i>									
LH Exhaust pipe with muffler		D64-7806-12-00 ()	Diamond Aircraft						
RH Exhaust pipe with muffler		D64-7806-12-00 ()	Diamond Aircraft						
LH Exhaust pipe		D65-7806-10-00 ()	Diamond Aircraft						
RH Exhaust pipe		D65-7806-10-00 ()	Diamond Aircraft						
<i>PROPELLER</i>									
Propeller LH	MTV-6-R-C-F/CF190-69		mt-propeller						
Propeller RH	MTV-6-R-C-F/CF190-69		mt-propeller						
Unfeathering accumulator LH		P-893-3	mt-propeller						
Unfeathering accumulator RH		P-893-3	mt-propeller						
Governor LH		P-877-16	mt-propeller						
Governor RH		P-877-16	mt-propeller						
<i>FUEL TANK SYSTEM</i>									
Fuel probe assy., LH inboard		D60-2817-13-00_1	Diamond Aircraft						
Fuel probe assy., RH inboard		D60-2817-13-00_1	Diamond Aircraft						
Fuel probe assy, LH inboard		D64-2817-13-00	Diamond Aircraft						
Fuel probe assy, RH inboard		D64-2817-13-00	Diamond Aircraft						
Fuel probe assy., LH outboard		D60-2817-14-00_1	Diamond Aircraft						

Airplane Serial No.:		Registration:		Date:		Mass		Lever Arm	
Description	Type	Part No.	Manufacturer	S/N	Installed	lb	kg	in	m
Fuel probe assy., RH outboard		D60-2817-14-00_1	Diamond Aircraft						
Alternate means for fuel qty.		D60-2817-90-00	Diamond Aircraft						
Alternate means for fuel qty. II		D60-2817-90-00_01	Diamond Aircraft						
AUX FUEL SYSTEM									
LH auxiliary fuel pump		PX375-TC-28V	Andair						
RH auxiliary fuel pump		PX375-TC-28V	Andair						
LH auxiliary fuel pump		5100-9	Dukes						
RH auxiliary fuel pump		5100-9	Dukes						
LH auxiliary fuel pump		PX375-TC-28V-G2	Andair						
RH auxiliary fuel pump		PX375-TC-28V-G2	Andair						
LH check valve		X11-0013-00-00.00	Hydraulik Mayer						
RH check valve		X11-0013-00-00.00	Hydraulik Mayer						
LH fuel inline filter		FX375-MK	Andair						
RH fuel inline filter		FX375-MK	Andair						
LH solenoid valve		VE 131,4 GV	Parker						
RH solenoid valve		VE 131,4 GV	Parker						
ICE PROTECTION SYSTEM									
Porous panel, outer wing, LH		12102-21	CAV Aerospace						
Porous panel, outer wing, RH		12102-22	CAV Aerospace						
Porous panel, center wing, LH		12102-23	CAV Aerospace						
Porous panel, center wing, RH		12102-24	CAV Aerospace						
Porous panel, horizontal tail, LH		12102-25	CAV Aerospace						

Airplane Serial No.:		Registration:		Date:		Mass		Lever Arm	
Description	Type	Part No.	Manufacturer	S/N	Installed	lb	kg	in	m
Porous panel, horizontal tail, RH		12102-26	CAV Aerospace						
Porous panel, vertical tail		12102-27	CAV Aerospace						
Porous panel, outer wing, LH		12102-31	CAV Aerospace						
Porous panel, outer wing, RH		12102-32	CAV Aerospace						
Porous panel, center wing, LH		12102-33	CAV Aerospace						
Porous panel, center wing, RH		12102-34	CAV Aerospace						
Porous panel, horizontal tail, LH		12102-35	CAV Aerospace						
Porous panel, horizontal tail, RH		12102-36	CAV Aerospace						
Porous panel, vertical tail		12102-37	CAV Aerospace						
Inlet strainer		12121-02	CAV Aerospace						
Spray bar		12124-10	CAV Aerospace						
Metering pump 1		9513A-386	CAV Aerospace			4.180	1.896	40.160	1.020
Metering pump 2		9513A-386	CAV Aerospace			4.180	1.896	40.160	1.020
De-icing fluid tank		D60-3013-24-50	Diamond Aircraft			8.140	3.692	38.390	0.975
Mod filter assy 1		D60-3013-11-90	Diamond Aircraft			0.680	0.308	40.160	1.020
Mod filter assy 2		D60-3013-11-90	Diamond Aircraft			0.680	0.308	40.160	1.020
Solenoid valve		FV158H-28V	CAV Aerospace			0.870	0.395	40.160	1.020
Solenoid valve		FV158H-28V	CAV Aerospace			0.870	0.395	40.160	1.020
High pressure switch		P041ED850	CAV Aerospace						
Proportioning unit, nacelle, LH		PU300DW142	CAV Aerospace						
Proportioning unit, nacelle, RH		PU300DW142	CAV Aerospace						
Tail bracket assembly		12132-03	CAV Aerospace			1.070	0.485	278.700	7.080
Tail bracket assembly		12132-14	CAV Aerospace			0.750	0.340	278.700	7.080
Windshield pump 1		WP209A	CAV Aerospace			0.650	0.295	40.160	1.020
Windshield pump 2		WP209A	CAV Aerospace			0.650	0.295	40.160	1.020
De-ice control box		DAI-9030-00-01	Diamond Aircraft						

Airplane Serial No.:		Registration:		Date:		Mass		Lever Arm	
Description	Type	Part No.	Manufacturer	S/N	Installed	lb	kg	in	m
<i>CABIN COOLING SYSTEM</i>									
Cabin cooling central unit		D44-2151-00-00	Diamond Aircraft			63.3	28.7	178.0	4.52
Cabin cooling central unit		D44-2153-00-00	Diamond Aircraft			46.7	21.2	178.0	4.52
AIRPLANE FLIGHT MANUAL		Doc. No. 7.01.16-E	Diamond Aircraft						

- The Amerex A 620 T is UL approved and can be used in airplanes registered in Canada and the USA. For airplanes registered in other countries contact the local Airworthiness Authority.

Place: _____

Date: _____

Signature: _____

CHAPTER 7

DESCRIPTION OF THE AIRPLANE AND ITS SYSTEMS

	Page
7.1 INTRODUCTION	7-3
7.2 AIRFRAME	7-3
7.3 FLIGHT CONTROLS	7-4
7.4 INSTRUMENT PANEL	7-11
7.5 LANDING GEAR	7-14
7.6 SEATS AND SAFETY HARNESSSES	7-20
7.7 BAGGAGE COMPARTMENT	7-24
7.8 CANOPY, REAR DOOR, AND CABIN INTERIOR	7-24
7.9 POWER PLANT	7-29
7.9.1 ENGINES, GENERAL	7-29
7.9.2 PROPELLER	7-30
7.9.3 OPERATING CONTROLS	7-33
7.9.4 ENGINE INSTRUMENTS	7-37
7.9.5 FUEL SYSTEM	7-40
7.9.6 COOLING SYSTEM	7-56
7.9.7 OIL SYSTEMS	7-57
7.9.8 TURBO-CHARGER SYSTEM	7-58
7.9.9 FIRE DETECTION SYSTEM	7-59
7.10 ELECTRICAL SYSTEM	7-60
7.10.1 GENERAL	7-61
7.10.2 ELECTRONIC ENGINE CONTROL UNIT / ECU	7-67
7.10.3 WARNING, CAUTION AND ADVISORY MESSAGES	7-69
7.11 PITOT-STATIC SYSTEM	7-75

7.12 STALL WARNING SYSTEM 7-75

7.13 GARMIN G1000 INTEGRATED AVIONICS SYSTEM 7-76

 7.13.1 GENERAL 7-76

 7.13.2 PRIMARY FLIGHT DISPLAY (PFD) 7-78

 7.13.3 MULTI-FUNCTION DISPLAY (MFD) 7-80

 7.13.4 AUDIO PANEL 7-81

 7.13.5 ATTITUDE AND HEADING REFERENCE SYSTEM (AHRS)
 7-81

 7.13.6 AIR DATA COMPUTER (ADC) 7-81

 7.13.7 GWX 68 / GWX 70 WEATHER RADAR 7-81

7.14 AVIONICS 7-82

 7.14.1 AUTOPILOT SYSTEM 7-82

 7.14.2 AUTOMATIC FLIGHT CONTROL SYSTEM ANNUNCIATIONS AND
 ALERTS 7-88

7.15 MID CONTINENT MD302 STANDBY ATTITUDE MODULE 7-90

7.1 INTRODUCTION

Chapter 7 contains a description of the airplane and its systems, together with operating instructions.

For details about optional equipment see Chapter 9.

7.2 AIRFRAME

Fuselage

The CFRP fuselage is of semi monocoque molded construction. The center wing is attached to the fuselage with bolts. The two main spars and both nacelles are part of the center wing. The two main spars are CFRP items. The engine compartment in each nacelle is separated from the other structure with a firewall. The fire protection on the firewall is of a special fire-resistant matting, which is covered on the engine side by stainless steel cladding.

Wings

The wings have a front and rear spar; each wing has a top shell and a bottom shell; The whole wing is 'fail-safe' design. The wings, as well as the ailerons and flaps, are made of GFRP/CFRP, and are principally of sandwich construction. An aluminum fuel tank is installed in each of the wings.

Empennage

The airplane has a 'T' tail of GFRP/CFRP semi monocoque construction. Both the stabilizers have twin spars. Rudder and elevator are of sandwich construction.

7.3 FLIGHT CONTROLS

The ailerons, elevator and wing flaps are operated through control rods, while the rudder is controlled by cables. The flaps are electrically operated. Elevator forces can be balanced by a trim tab on the elevator, which is operated by a Bowden cable. Rudder forces can be balanced by a trim tab on the rudder, which is also operated by a Bowden cable.

Ailerons

Construction: GFRP/CFRP composite sandwich.

Hinges: There are 4 hinges, which are hinge pins mounted in an aluminum bracket. They are secured in position by a roll pin. The absence of this roll pin can lead to the loss of the hinge pin and a consequent loss of flight safety.

Operation: Each aileron is connected with a aileron control horn to the push rods of the aileron control system. A rod end bearing is screwed into a steel push rod and locked by means of a jam nut which has locking varnish applied to it. Damage to this varnish can indicate a twisting and thus a change to the adjustment. The connection between the rod end bearing and the control horn is a bolt, the nut of which is likewise sealed with locking varnish. The aileron control horn is fully covered by a fairing mounted to the aileron control horn with three screws.

The aluminum control horn is attached to the aileron with 3 screws.

Flaps

The flaps are a two piece construction. The inner part of the flap is mounted to the center wing and the outer part to the wing. Both parts are connected to each other with a form fit connection.

Construction: GFRP/CFRP composite sandwich.

Hinges: There are 6 hinges at the outer part and 4 hinges at the inner part of the flap. These hinges are hinge pins mounted in an aluminum bracket. They are secured in position by a roll pin. The absence of this roll pin can lead to the loss of the hinge pin and a consequent loss of flight safety.

Operation: Each part is connected with a flap control horn to the push rods of the flap control system. A rod end bearing is screwed into a steel push rod and locked by means of a jam nut which has locking varnish applied to it. Damage to this varnish can indicate a twisting and thus a change to the adjustment. The connection between the rod end bearing and the control horn is a bolt, the nut of which is likewise sealed with locking varnish. The flap control horn is fully covered by a fairing mounted to the flap control horn with three screws in the outer wings and four screws in the center wing.

Each flap control horn is attached to the flap part with 3 screws.

The flaps are driven by an electric motor and have 3 settings:

- Cruise (UP), totally retracted
- Approach (APP), and
- Landing (LDG).

The flaps are operated by means of a 3-position flap selector switch on the instrument panel. The positions of the switch correspond to the positions of the flaps, the Cruise position of the switch being at the top. If the switch is moved to another position, the flaps continue to travel automatically until they have reached the position selected on the switch. The UP and LDG positions are additionally protected by a limit switch to guard against over-running the end positions.

The electrical flap drive has an automatic circuit breaker which can also be operated manually.

Flap Position Indicator:

The current flap position is indicated by means of three lights beside the flap selector switch.

When the upper light (green) is illuminated, the flaps are in the Cruise position (UP);

when the center light (white) is illuminated, the flaps are in Approach position (APP);

when the lower light (white) is illuminated, the flaps are in Landing position (LDG).

When two lights are illuminated simultaneously, the flaps are between the two indicated positions. This is the case only when the flaps are in transition.

Elevator

Construction: GFRP sandwich.

Hinges: 5 hinges.

Operation: Steel pushrods;

Two of the bellcrank bearings are accessible for visual inspection next to the lower hinge of the rudder. The elevator horn and its bearing, as well as the connection to the pushrod, can be visually inspected at the upper end of the rudder.

Variable Elevator Stop:

The DA 42 NG is equipped with an electrically operated actuator that limits the elevator-up travel to 13° as soon as the power setting of both engines exceeds approximately 20 % (approach power setting). This is 2.5° less than the 15.5° full deflection.

The linear actuator acts as a movable stop and is controlled by two switches, one for each power lever. When the power of one engine is reduced below approximately 20 % full elevator deflection is regained.

An amber annunciation (CAUTION) on the G1000 display is provided to inform the pilot in case a malfunction occurs. The annunciation illuminates when the variable stop should be in place and is actually not activated (power on condition) or should be retracted and actually limits the elevator travel (power off condition).

Rudder

Construction: GFRP sandwich.

Hinges: Upper hinge: One bolt.

Lower hinge: Bearing bracket including rudder stops, held by 4 screws to the rear web of the vertical stabilizer. The mating part on the rudder is a bracket which is attached to the rudder by 2 bolts. The bolts and nuts are accessible to visual inspection.

Operation: Steel cables, the eyes of which are connected to the bolts on the bracket.

The gap between the vertical tail and the rudder is sealed with gap seal tape made of PTFE/Teflon® on both sides.

Elevator Trim

The trim control is a black wheel in the center console to the rear of the power lever. To guard against overrotating, the trim wheel incorporates a friction device. A mark on the wheel shows the take-off (T/O) position.

Turn wheel to the front = nose down

Turn wheel to the rear = nose up

Rudder Trim

The trim control is a black wheel in the center console below the instrument panel. A mark on the wheel shows the center position and the direction of movement.

Turn wheel to the right = right turn

Turn wheel to the left = left turn

Pedal Adjustment

NOTE

The pedals may only be adjusted on the ground!

The pedals are unlocked by pulling the black handle which is located behind the rear attachment.

Forward Adjustment:

Whilst keeping the handle pulled, push the pedals forward with your feet. Release the handle and allow the pedals to lock into place.

Rearward Adjustment:

Using the unlocking handle, pull the pedals back to the desired position. Release the handle and push the pedals forward with your feet until they lock into place.

Electrical Pedal Adjustment (Optional Equipment, OÄM 42-070)**NOTE**

The pedals may only be adjusted on the ground!

The pedals are adjusted using a rocker switch, located on the rear wall of the leg room. The related circuit breaker is located below the switch.

Forward Adjustment:

To move the pedals forward, depress lower side of switch. When pedals are in correct position, release switch.

Rearward Adjustment:

To move the pedals in the rearward direction, depress upper side of switch. When pedals are in correct position, release switch.

Locking:

Upon release the switch moves automatically to the 'power off' position, so locking the pedals in the present position.

7.4 INSTRUMENT PANEL

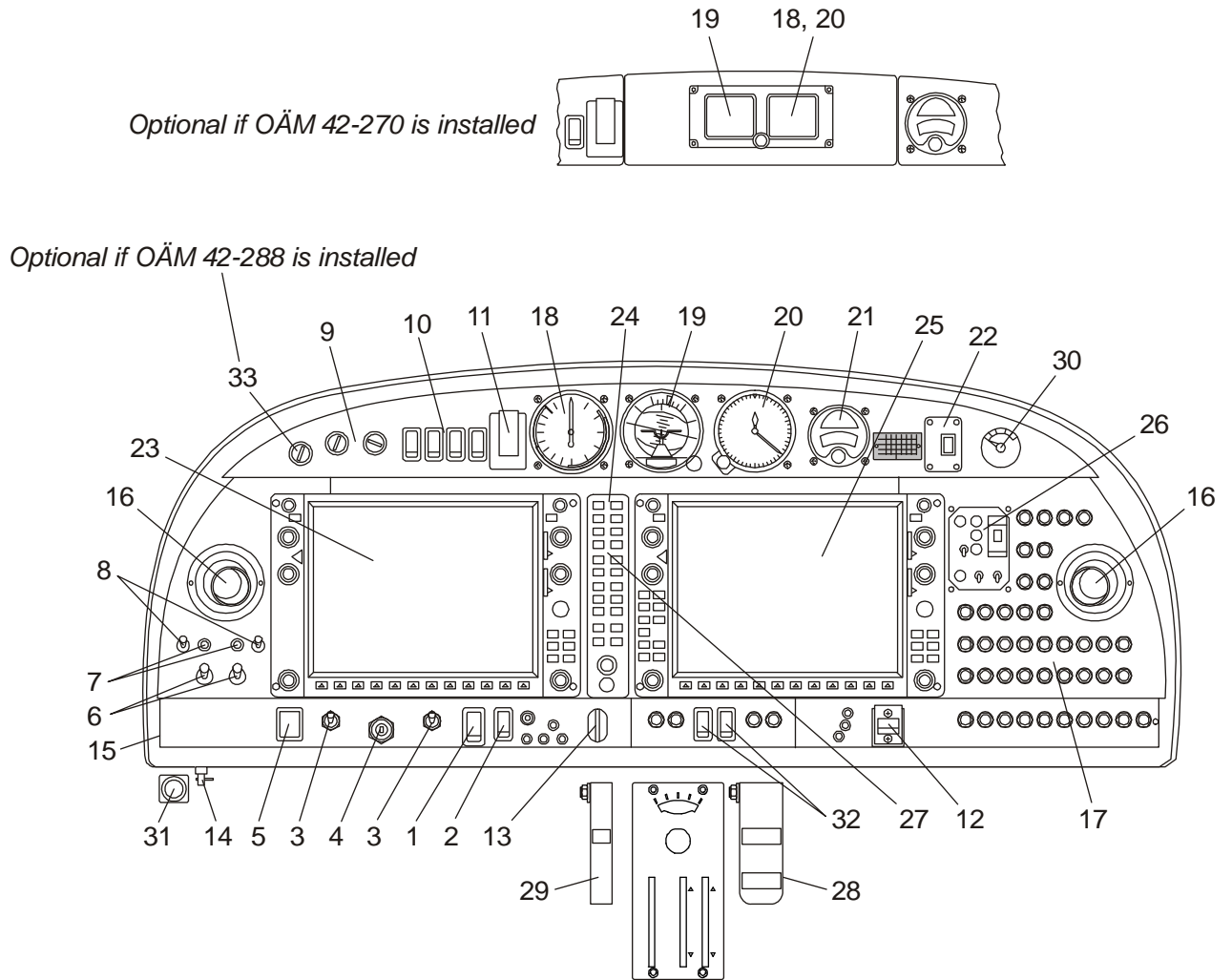

NOTE

The figure above shows the typical DA 42 NG installation position for the equipment. The actual installation may vary due to the approved equipment version.

Major Instruments and Controls	
1 Electric master switch	17 Circuit breakers*
2 Avionic master switch	18 Backup airspeed indicator
3 Engine master switches	19 Backup artificial horizon
4 Start switch	20 Backup altimeter
5 Pitot-/Stall warning heat switch	21 Emergency compass
6 Alternator switches	22 ELT control unit
7 ECU test buttons	23 Primary flight display (PFD)
8 VOTER switches	24 Audio amplifier / intercom / marker beacon receiver
9 Rotary buttons for instrument lighting and flood light	25 Multi function display (MFD)
10 Light switches	26 De-ice control panel
11 Emergency switch	27 Autopilot control unit (part of MFD)
12 Flap selector switch	28 Alt air lever
13 Landing gear switch	29 Landing gear emergency extension lever
14 Alternate static valve	30 Oxygen pressure indicator
15 Microphone socket	31 Oxygen control knob
16 Ventilation nozzles	32 Fuel pump switches
	33 Gear warning mute button (if installed)

*) Designations and abbreviations used to identify the circuit breakers are explained in Section 1.5 - DEFINITIONS AND ABBREVIATIONS.

Cockpit Ventilation

Ventilation in the front is provided by spherical ventilation nozzles (16) in the instrument panel. Furthermore there are spherical nozzles in the roll bar on the left and right side next to the front seats as well as on the central console above the passengers' heads. The spherical nozzles are opened and closed by twisting.

Unconditioned ambient air is supplied to the interior through an inlet on the lower side of the RH center wing stub. To increase cabin temperatures when operating at low outside air temperatures, a winter kit - ventilation may be installed at the inlet.

The winter kit - ventilation consists of a metal plate with rubber edging and is attached to the lower side of the RH center wing stub by a camloc.

7.5 LANDING GEAR

The landing gear is a fully retractable, hydraulically operated, tricycle landing gear. Struts for the landing gear are air oil assemblies.

The hydraulic pressure for the landing gear operation is provided by an electrically powered hydraulic pump, which is activated by a pressure switch, when the required pressure is too low. Electrically actuated hydraulic valves, which are operated with the gear selector switch, provide the required hydraulic pressure for the movement of the landing gear. The gear selector switch is located on the instrument panel. The switch must be pulled out before it is moved to UP or DOWN position. Gear extension normally takes 6-10 seconds.

When the landing gear is retracted, the main wheels retract inboard into the center wing and the nose wheel retracts forward into the nose section. Hydraulic pressure on the actuators keeps the landing gear in the retracted position. A pressurized gas container acts as an accumulator which keeps the system pressure constant by replacing the volume lost due to the normal actuator leakages. This prevents a permanent starting of the hydraulic pump in flight.

Springs assist the hydraulic system in gear extension and locking the gear in the down position. After the gears are down and the downlock hooks engage, springs maintain force on each hook to keep it locked until it is released by hydraulic pressure.

The three green lights directly next to the landing gear operating switch illuminate to indicate that each gear is in the correct position and locked. If the gear is in neither the full up nor the full down position, a red warning light on the instrument panel illuminates.

Should one power lever be placed in a position below approx. 20 % while the landing gear is retracted, a warning horn sounds to alert the pilot that the gear is retracted. Additionally, a CHECK GEAR caution is indicated on the PFD. The same warning appears if the flaps move into position LDG (fully extended) while the gear is retracted.

To test the gear warning system (refer to 4A.6.1 - PRE-FLIGHT INSPECTION) push the test button close by the gear selector switch. The aural gear alert should appear.

CAUTION

If the aural alert does not appear, an unscheduled maintenance is necessary.

If OÄM 42-288 is installed and the aural gear warning is activated, the aural alert can be deactivated by pressing the GEAR WARNING MUTE button. The aural gear warning is reset to normal operation, if one of the power levers is moved to a position of 20 % \pm 5 % or higher. Thus the aural gear warning alert will sound again, if one of the power levers is moved to a position of 20 % \pm 5 % or lower.

To prevent inadvertent gear retraction on ground, an electric squat switch prevents the hydraulic valve from switching if the master switch is on and the gear extension switch is placed in the UP position.

After take-off, the gear should be retracted before an airspeed of 152 KIAS is exceeded. The landing gear may be extended at any speed up to 188 KIAS.

The landing gear is designed to be manually operated in the event of failure. Since the gear is held in the retracted position by hydraulic pressure, gravity will allow the gear to extend if the system fails for any reason. To extend and lock the gears in the event of failure, it is only necessary to relieve the hydraulic pressure by means of the emergency gear extension lever, which is located under the instrument panel to the left of the center console. Pulling this lever releases the hydraulic pressure and allows the gear to fall free. Before pulling the emergency gear extension lever, place the gear selector switch in the DOWN position.

NOTE

If the emergency gear extension has been pulled due to an emergency, the system has to be checked before pushing the lever in again.

The nose gear is steerable by the use of full rudder pedal travel. A gear damping element, incorporated in the nose gear steering system, prevents shimmy tendencies. When the gear is retracted, the nose wheel centers as it enters the wheel well, and the steering linkage disengages to reduce pedal loads in flight.

Hydraulic Gear Extension System Schematic

The main landing gear of the DA 42 NG is extended with three hydraulic cylinders. The following schematic figures show the system conditions for each operating mode. The figure below shows the extension of the landing gear. To reduce the amount of pumped hydraulic fluid during this operation, the return flow is partly led into the feeding flow of the system.

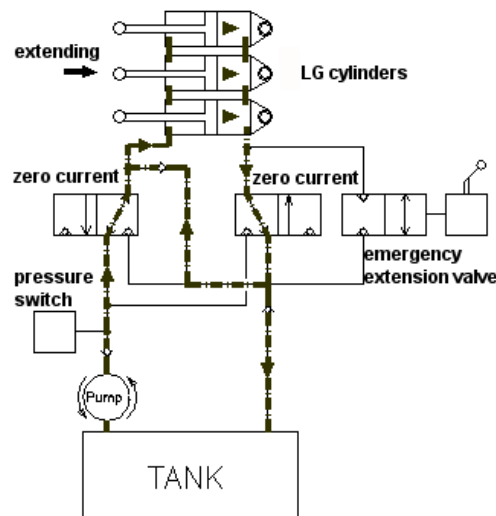

The figure below shows the system status when the landing gear is extended. All hydraulic cylinders are under high pressure.

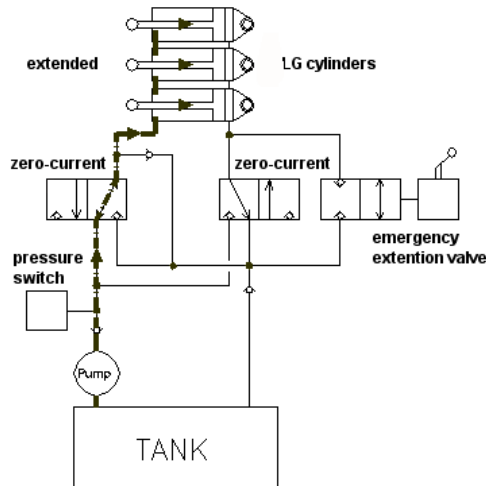

The operating mode for the retraction of the landing gear is shown in the next figure. While energizing the right hydraulic valve, the fluid flow in the hydraulic system is started due to different piston areas of the landing gear cylinders although the pressure on both sides of the system is equal.

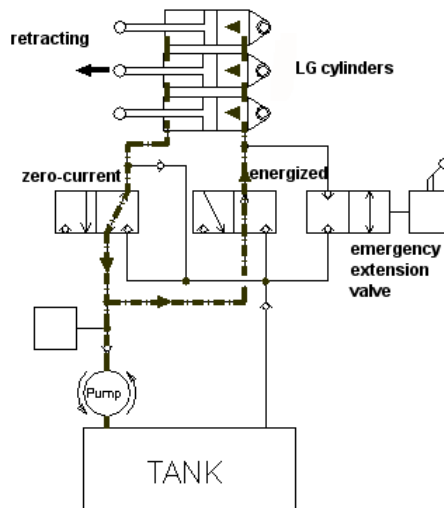

While the landing gear is retracted both valves are energized and excessive hydraulic fluid on one side is drained into the tank. This configuration of the system is shown in the following figure.

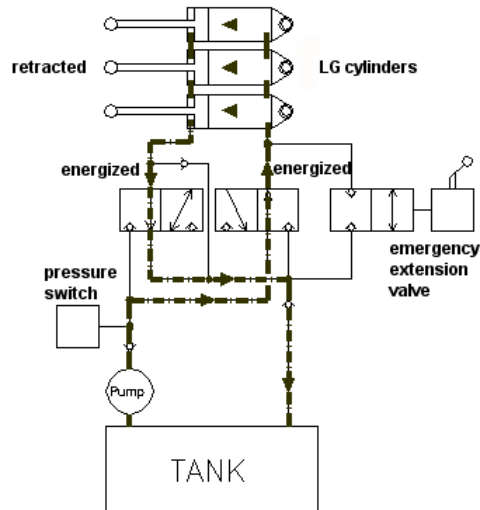

For an emergency extension of the landing gear, the hydraulic fluid can pass through an emergency extension valve so that the gear is extended by gravity. The condition of the system is shown in the figure below.

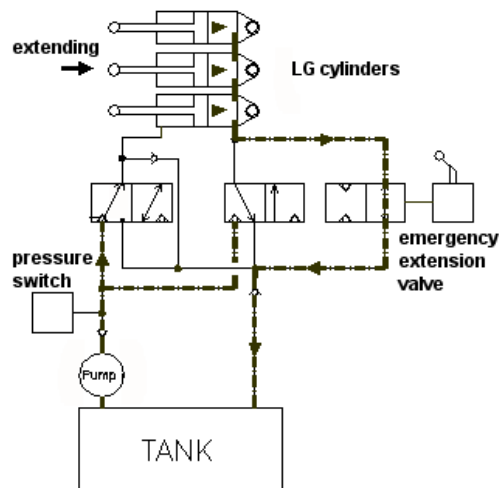

Wheel Brakes

Hydraulically operated disk brakes act on the wheels of the main landing gear. The wheel brakes are individually operated by means of toe pedals.

Parking Brake

The lever is located on the small center console under the instrument panel and is in the upper position when the brakes are released. To operate the parking brake, pull the lever downwards until it catches. Brake pressure is built up by multiple operation of the toe brake pedals, and is maintained until the parking brake is released. To release, the lever is pushed upwards.

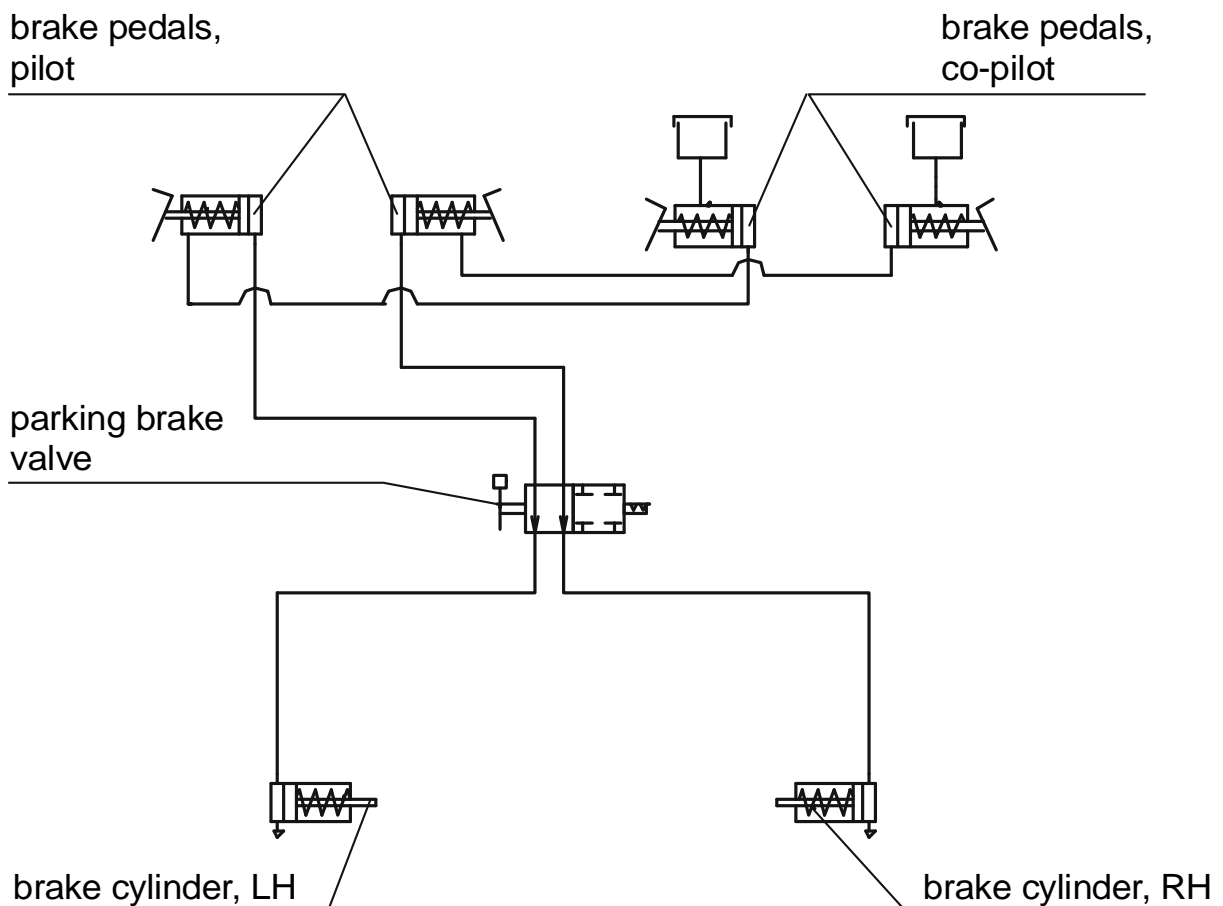

7.6 SEATS AND SAFETY HARNESSSES

To increase passive safety, the seats are constructed using a carbon fiber/Kevlar hybrid material and GFRP. The seats are removable to allow maintenance and inspection of the underlying controls. Covers on the control sticks prevent loose objects from falling into the area of the controls.

The seats have removable furnishings and are equipped with energy-absorbing foam elements.

The seats are fitted with three-part safety harnesses. The harnesses are fastened by inserting the end of the belts in the belt lock, and are opened by pressing the red release on the belt lock.

The backs of the rear seats can be laid forward after pulling upwards on the locking bolt knob.

If front seats with adjustable backrests are installed (OÄM 42-067 or OÄM 42-259), the angle of the backrest and the lumbar can be adjusted for best comfort. The backrest control lever is situated on the outboard side of the backrest if OÄM 42-067 is installed. The backrest release button, in case of OÄM 42-259 is situated on the upper side of the seat's side frame. However, during take-off, landing and emergency landing the backrests must be fixed in the upright position designated by a placard on the roll-over bar.

The lumbar support can be adjusted by operating the lumbar support lever mounted on the outboard side of the seat pan.

CAUTION

Before adjusting the angle, lean against the backrest to counteract the spring load; otherwise the backrest may slap forward.

CAUTION

Don not apply a load of more than 90 daN (202lbf) to the top of the backrest. Otherwise damage of the adjustment mechanism may result.

For adjustment lift the backrest lever or press the button and bend the backrest forward or backward to the desired backrest angle. For fixing the position press down the backrest lever or release the button.

If OÄM 42-259 is installed and in case of a malfunction of the release button the backrest can be moved into the upright position by pulling the backrest (480 N) in flight (FWD) direction.

If OÄM 42-067 is installed and in case of a defective adjustment mechanism the outboard friction adjustment screw can be tightened with a 10 mm hexagon nut in clockwise direction in order to fix the backrest in the upright position.

If possible, set the backrest lever to the locked position. The mechanism must be repaired at the next scheduled inspection.

If seats with adjustable backrests are installed (OÄM 42-067):

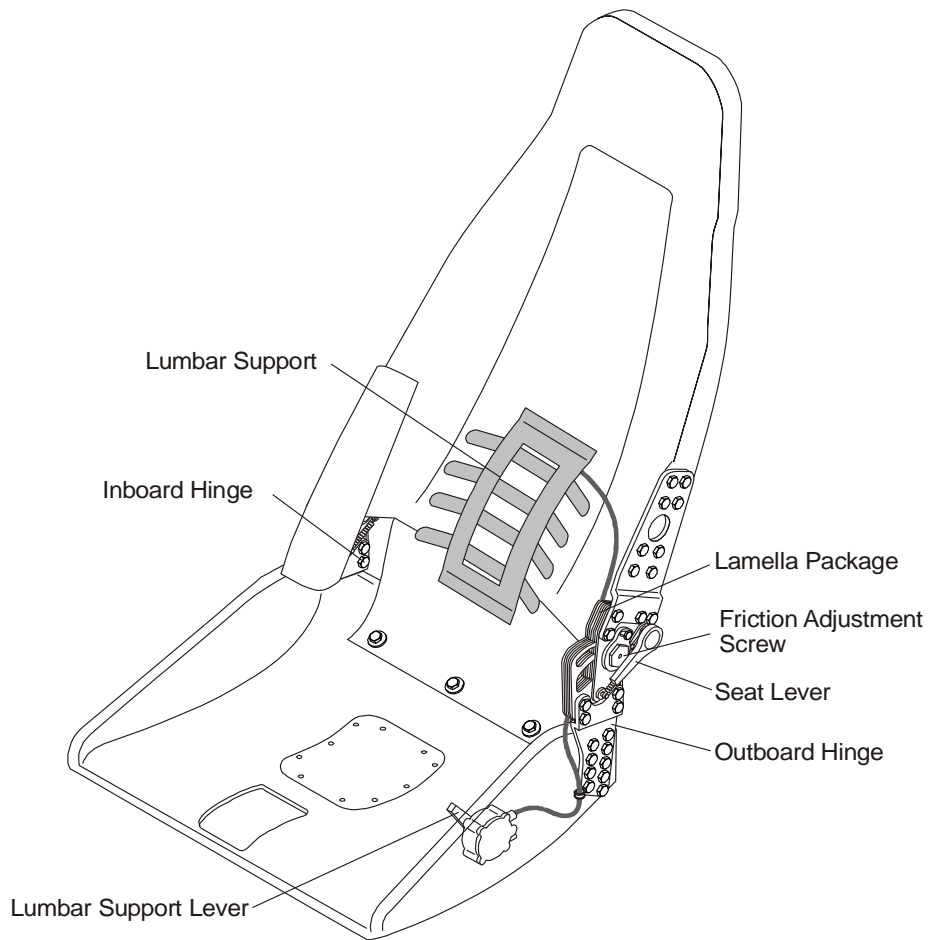

If seats with adjustable backrest are installed (OÄM 42-259):

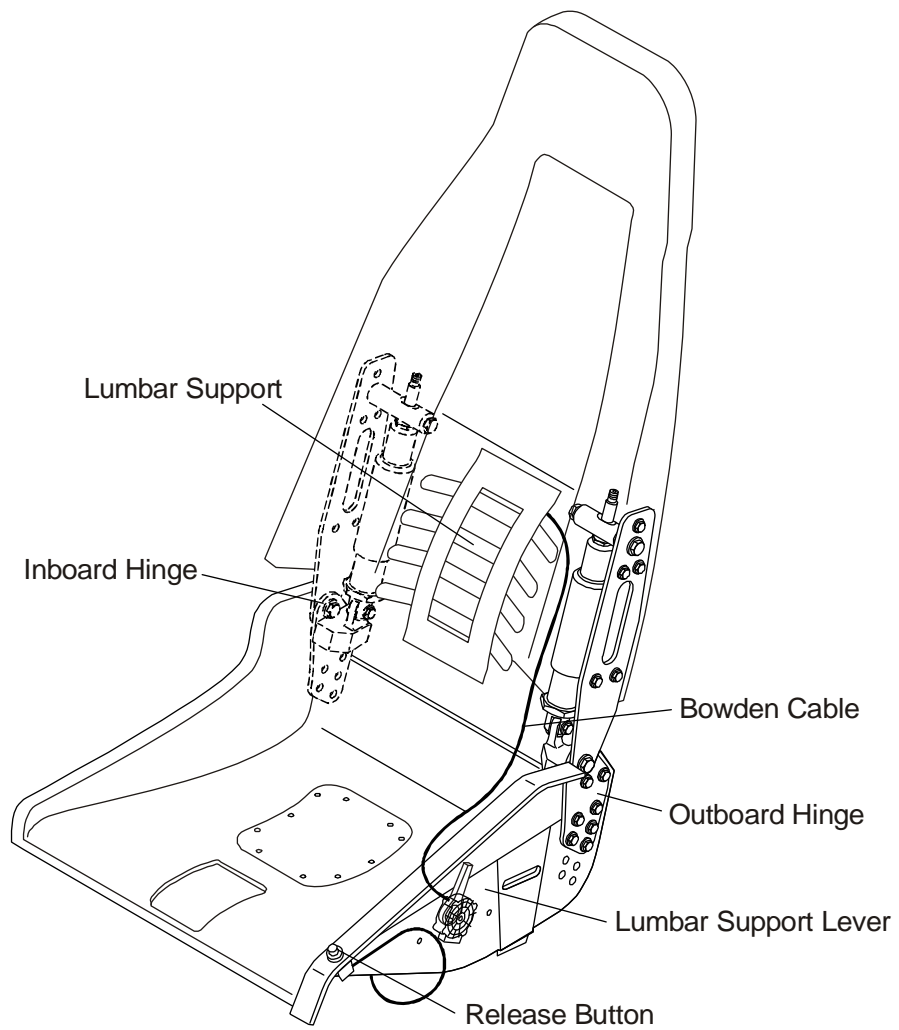

7.7 BAGGAGE COMPARTMENT

There are two baggage compartments. One is located in the nose section and it is accessible through two compartment doors.

The other baggage compartment is behind the seat backs of the rear seats. As an option a short baggage extension (OÄM 42-207) may be installed.

Baggage may be loaded there and must be restrained by means of a baggage net.

NOTE

If OÄM 42-207 is installed, make sure that the baggage does not block the air vents in the back wall of the short baggage extension.

7.8 CANOPY, REAR DOOR, AND CABIN INTERIOR

Front Canopy

The front canopy is closed by pulling down on the canopy frame, following which it is locked by means of a handle on the left hand side of the frame. On locking, steel bolts lock into mating holes in polyethylene blocks.

"Cooling gap" position: a second setting allows the bolts to lock in, leaving a gap under the forward canopy.

The canopy can be blocked by a locking device on the left side near the canopy opening lever by turning the key clockwise. The closed and blocked canopy can be opened from inside by pulling the lever inside the opening handle.

WARNING

The airplane may be operated with the front canopy in the “cooling gap” position on the ground only. Before take-off the front canopy must be completely closed and locked.

Do not block the front canopy with the locking key before flight in order to assure emergency evacuation from outside.

A window on the left and right hand side of the canopy can be opened for additional ventilation or as an emergency window.

Rear Door

The rear door is closed in the same way, by pulling down on the frame and locking it with the handle. A gas pressure damper prevents the door from dropping; in strong winds the assembly must be securely held. The rear door is protected against unintentional opening by an additional lever.

The door can be blocked by a locking device on the left side near the door opening lever by turning the key clockwise. The closed and blocked door can be opened from inside by pulling the lever inside the opening handle.

WARNING

Do not block the door with the locking key before flight in order to assure emergency access from outside.

Heating and Ventilation

Heating and ventilation are operated using two levers located on the small center console under the instrument panel.

Right lever:	up	= HEATING ON (seats, floor)
	down	= HEATING OFF
Center lever :	up	= DEFROST ON (airflow to canopy)
	down	= DEFROST OFF

The heat of the RH engine is used for the front seats and floor, the heat of the LH engine is used to defrost the canopy.

The air inlet for the ventilation system is placed on the underside of the RH wing, inboard of the engine nacelle. The air is distributed within the cabin via 6 nozzles (2 on the instrument panel LH/RH side, 2 on the overhead panel and 2 on the LH/RH side of the passenger compartment). The jet direction of each cone can be changed easily and the jet intensity can be regulated by rotation of the nozzle.

Emergency Axe

If OÄM 42-205 is incorporated an emergency axe is installed on the floor panel under the co-pilot's seat (see Figure below).

If the canopy can not be opened in case of an emergency use the emergency axe to break through the canopy.

WARNING

Make sure not to harm other persons by using the emergency axe.

WARNING

Beware of sharp edges and fragments of the broken canopy.

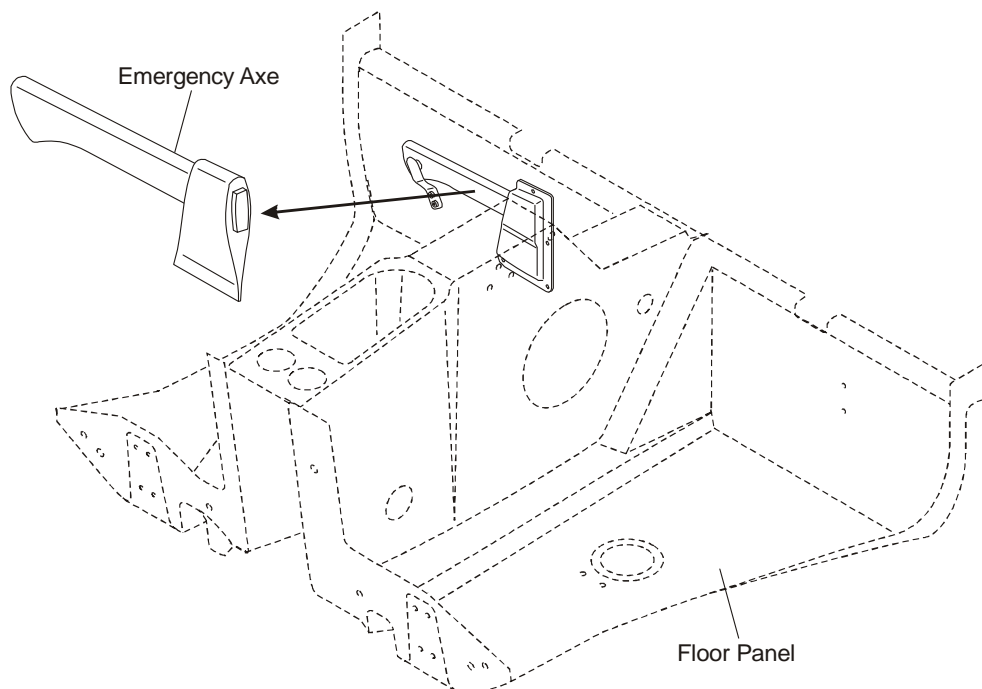

Emergency Egress Hammer

If OÄM 42-304 is incorporated an emergency egress hammer is installed on the floor panel under the co-pilot's seat.

If the canopy can not be opened in case of an emergency use the emergency egress hammer to break through the canopy.

WARNING

Make sure not to harm other persons by using the emergency egress hammer.

WARNING

Beware of sharp edges and fragments of the broken canopy.

| First Aid Kit

| The first aid kit is stored under the removable base plate of the baggage compartment.

7.9 POWER PLANT

7.9.1 ENGINES, GENERAL

There are two Austro Engine E4-C engines installed, which have the following specifications:

- Liquid-cooled four-cylinder four-stroke engine with wet sump lubrication
- Inline construction
- Common rail direct injection
- Propeller speed reducing gear 1:1.69
- Digital engine control with integrated propeller governor (separate oil system)
- Turbo charger with intercooler

Displacement:

Max. power: 123.5 kW (165.6 DIN-HP) at 2300 RPM at sea level and ISA

Max. continuous power: 113.6 kW (152.3 DIN-HP) at sea level and ISA

The indications for monitoring important engine parameters during operation are integrated within the Garmin G1000 display. Each engine can only be operated with the ENGINE MASTER switch ON. Each engine has an own ECU (Electronic Engine Control Unit) which receives its electrical power from the generator when at least one engine is running. When both engines are at standstill, the ECU receives its electrical power from the battery.

7.9.2 PROPELLER

Two mt-Propeller MTV-6-R-C-F / CF 190-69 hydraulically regulated 3-bladed constant speed feathering propellers are installed. Each propeller has wood composite blades with fiber-reinforced plastic coating and stainless steel edge cladding; in the region of the propeller hub the leading edge is coated with adhesive PU foil. These blades combine the lowest weight whilst minimizing vibration.

Propeller Control

The propeller pitch control system consists of the P-877-16 mt-Propeller governor valve. The pitch is set by the ECU via an electro-mechanical actuator on the governor. To change the blade pitch angle gearbox oil is pumped into the propeller hub. Increasing the oil pressure leads to a decrease of pitch and a higher RPM. Decreasing the pressure leads to higher pitch and a lower RPM.

Depending on the power setting the propeller pitch is adjusted such that the required RPM will be obtained as shown in the following diagram.

Propeller Setpoint Curve

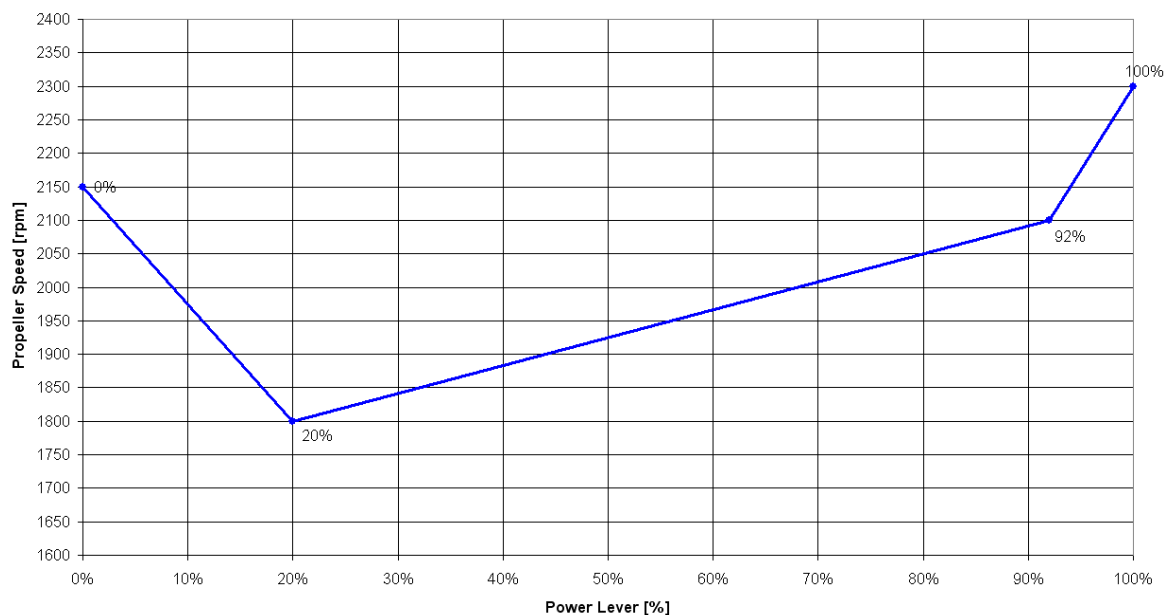

Pressure Accumulator:

The pressure accumulator is a nitrogen oil type. It is connected to the gearbox oil circuit via an electric valve at the accumulator, which is operated with the ENGINE MASTER switch.

When the ENGINE MASTER switch is set to ON the valve is opened. During engine operation the accumulator makes sure that enough oil pressure is available even if the oil feed by the gearbox oil pump is decreasing due to negative acceleration. The hydraulic pressure keeps the propeller pitch angle below the start lock position, or moves the propeller blades beyond the start lock position.

Feathering:

To feather the propeller the engine must be shut down with the appropriate ENGINE MASTER switch. This will open the electric governor valve. All oil will flow back from the propeller hub, allowing the blades to move into the feathered pitch position. At the same time the electric valve at the pressure accumulator closes, and the oil pressure is restored in the accumulator.

Feathering is only possible at propeller speeds above 1300 RPM.

CAUTION

If the engine is shut down below an RPM of 1300 the propeller pitch remains below the start lock position. In this case the speed must be increased to increase the propeller RPM.

Unfeathering:

To unfeather the propeller, the associated ENGINE MASTER switch must be set to ON. This will open the electric valve at the pressure accumulator. The pressure stored in the accumulator will move the propeller blades into a low pitch position. As soon as the propeller starts turning and the gearbox oil operates, the accumulator will be refilled.

*Ground Operation:***CAUTION**

Operation on the ground at high RPM should be avoided as far as possible, as the blades could suffer stone damage. For this reason a suitable site for engine runs should be selected, where there are no loose stones or similar items.

WARNING

Never move the propeller by hand.

7.9.3 OPERATING CONTROLS

Power Lever

Engine performance is controlled by a power lever for each engine. Both power levers are situated on the large center console. 'Front' and 'rear' are defined in relation to the direction of flight.

Each power lever is used to set the desired engine power LOAD (%)

Lever forward (MAX) = Full power

Lever to rear (IDLE) = Idle

A separate ECU for each engine controls manifold pressure, injected fuel quantity and propeller speed according to the desired engine power preselected with the power lever. If the power lever is in a low power position - as for a landing approach - while the landing gear is retracted, an aural warning alerts the pilot to the retracted landing gear. Additionally, a CHECK GEAR caution is indicated on the PFD.

A propeller governor, which is controlled by the ECU, is flanged onto the front of each engine. The propeller governor oil circuit is supplied with oil by the gearbox oil pump (also see Section 7.9.2 - PROPELLER). A loss of oil pressure leads to a feathering of the propeller blades, thus allowing continuation of the flight according to 3.12.3 - DEFECTIVE PROPELLER RPM REGULATING SYSTEM.

CAUTION

Following governor failure the RPM should be adjusted using the power lever. Every effort should be made not to exceed 2300 RPM.

CAUTION

The power lever should be moved slowly, in order to avoid over-speeding and excessively rapid RPM changes. The light wooden propeller blades produce more rapid RPM changes than metal blades.

WARNING

It is possible that the propeller blades remain in the position of highest pitch in case of a malfunction of the engine control unit. In this case the reduced engine performance should be taken into consideration.

ELECT. MASTER

The ELECT. MASTER switch has two positions:

OFF disconnecting battery power

ON connecting battery power to the power distribution system

ENGINE MASTER

Each engine can only be cranked with its ENGINE MASTER switched to ON. When activated, the ENGINE MASTER provides the power supply for the preheat system, the unfeathering accumulator valve and the engine itself. To shut down the engine the appropriate ENGINE MASTER is switched to OFF.

START

Turning START key switch to the left starts the LH engine. Turning it to the right side starts the RH engine.

ECU VOTER

There are two VOTER switches, one for each engine. For normal operation both switches are set to AUTO. Each engine is controlled by either ECU A or ECU B. In case of a failure of the active electronic engine control unit (ECU) there should be an automatic switch-over to the other ECU. If the automatic switch over fails, switch over can be done manually by switching to ECU A or ECU B. This procedure should only be applied in an emergency.

ECU TEST

There are two ECU TEST buttons, one for each engine.

Power Lever at IDLE and RPM Below Approximately 900:

By pushing and holding the button until the end of the procedure, the self-test of each engine control unit is started. The procedure is possible on the ground only. Otherwise the test will not start. During the procedure the ECU performs a switch from ECU A to ECU B or ECU B to ECU A, whichever is active at the moment, with the propeller cycling. The propeller RPM is monitored automatically by the ECU. When switching from one ECU to the other, a slight shake of the engine may occur. Finally the ECU switches back. After that both caution lights must extinguish and the engine must run without a change.

Alternate Air

In the event of power loss because of icing or blocking of the air filter, there is the possibility of drawing air from the engine compartment. The ALTERNATE AIR operating lever which serves both engines simultaneously is located under the instrument panel to the right of the center console. To open the alternate air source the lever is pulled to the rear. Normally, the alternate air source is closed with the lever in the forward position.

Placard on the lever, forward position:

ALTERNATE AIR

Placard on the lever, visible when lever is in the rearward position:

**ALTERNATE AIR
ON**

7.9.4 ENGINE INSTRUMENTS

The engine instruments are displayed on the Garmin G1000 MFD. Also refer to Section 7.13.3 - MULTI FUNCTION DISPLAY (MFD). Indications for the LH engine are on the left side, indications for the RH engine are on the right side.

Default page
Engine

Display when pushing
the SYSTEM button
If Garmin G1000 NXi is
NOT installed

Display when pushing
the FUEL button
If Garmin G1000 NXi is
NOT installed

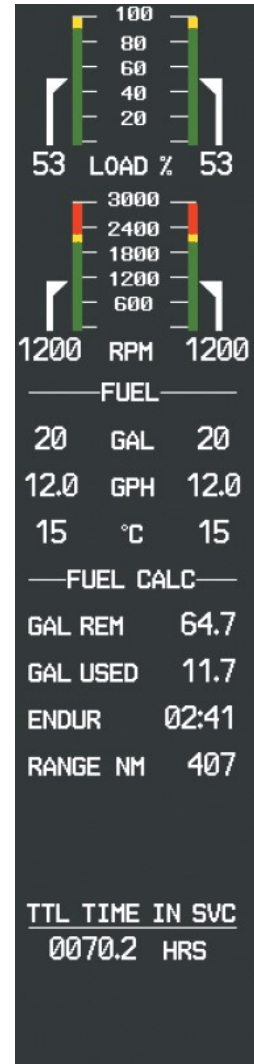
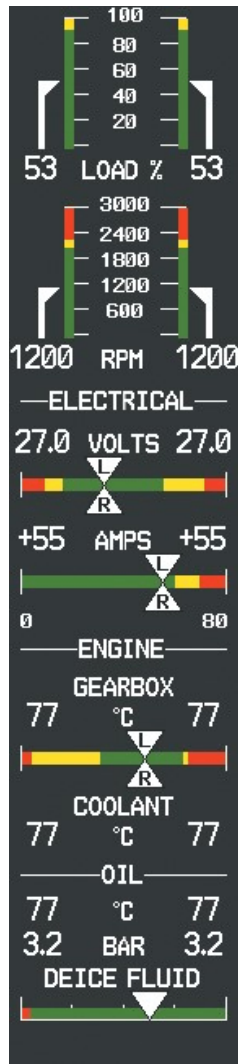
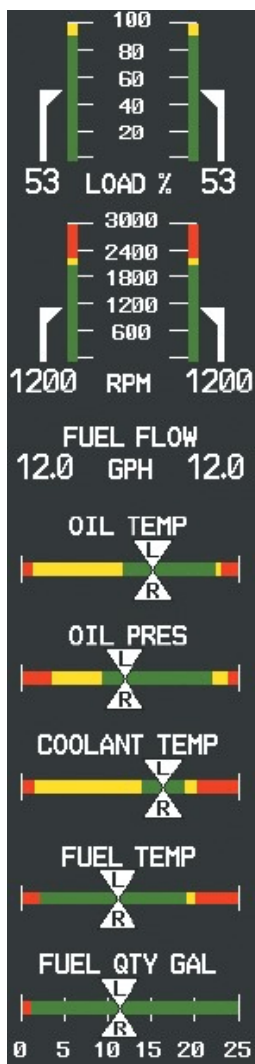

Display when pushing the ENGINE button (if Garmin G1000 NXi is installed):

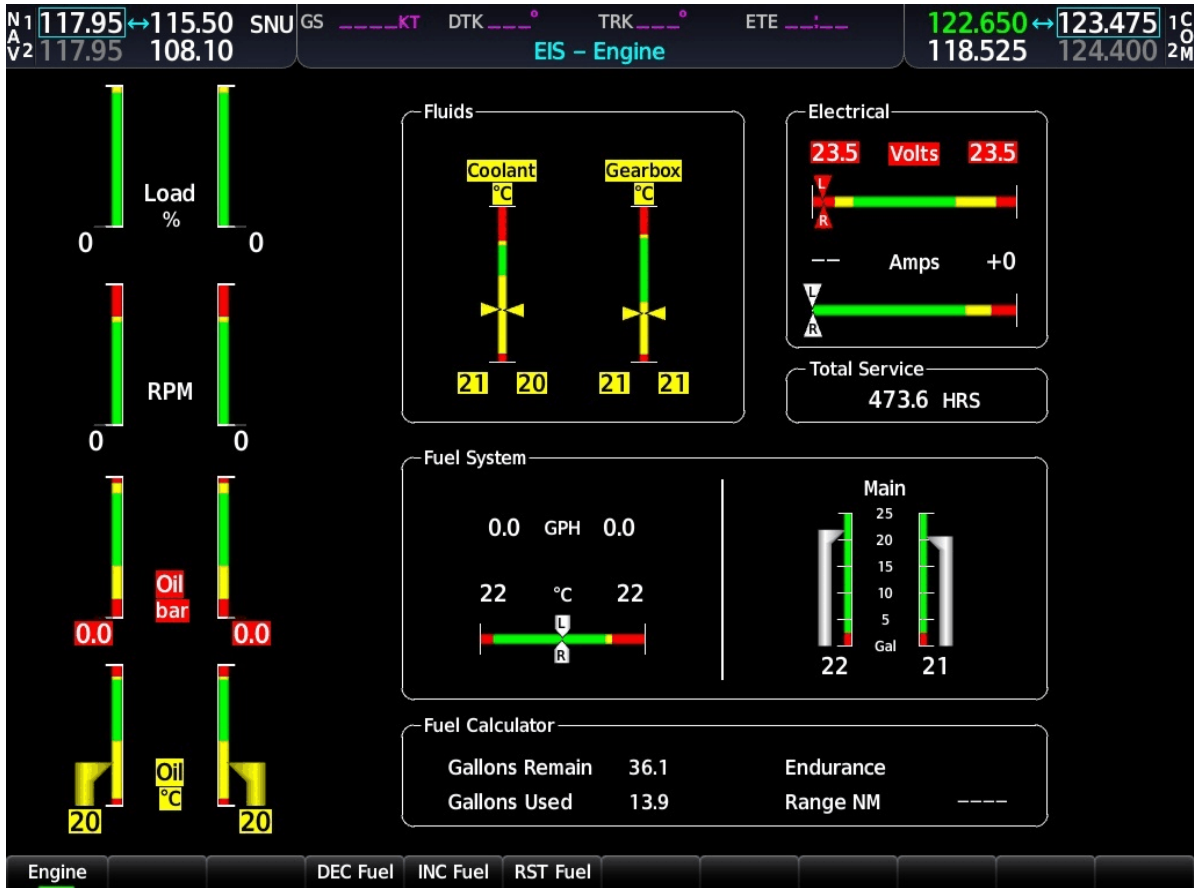

NOTE

The figure on previous page is a general demonstration of a typical G1000 MFD to show the different display modes. The pictured engine instrument markings may not stringently agree with the current engine limitations of the DA 42 NG.

NOTE

The fuel calculations on the FUEL CALC portion do not use the airplane's fuel quantity indicators. The values shown are numbers which are calculated from the last fuel quantity update done by the pilot and actual fuel flow data. Therefore, the endurance and range data is for information only, and must not be used for flight planning.

Designation	Indication	Unit
LOAD %	Available power	%
RPM	Propeller RPM	1/min
VOLTS	Volts	V
AMPS	Ampères	A
COOLANT TEMP	Coolant temperature	°C
GEARBOX	Gearbox temperature	°C
OIL TEMP	Engine oil temperature	°C
OIL PRES	Oil pressure	bar
FUEL QTY GAL	Fuel quantity	US gal
FUEL FLOW	Fuel flow	US gal/hr
FUEL TEMP	Fuel temperature	°C

7.9.5 FUEL SYSTEM

General

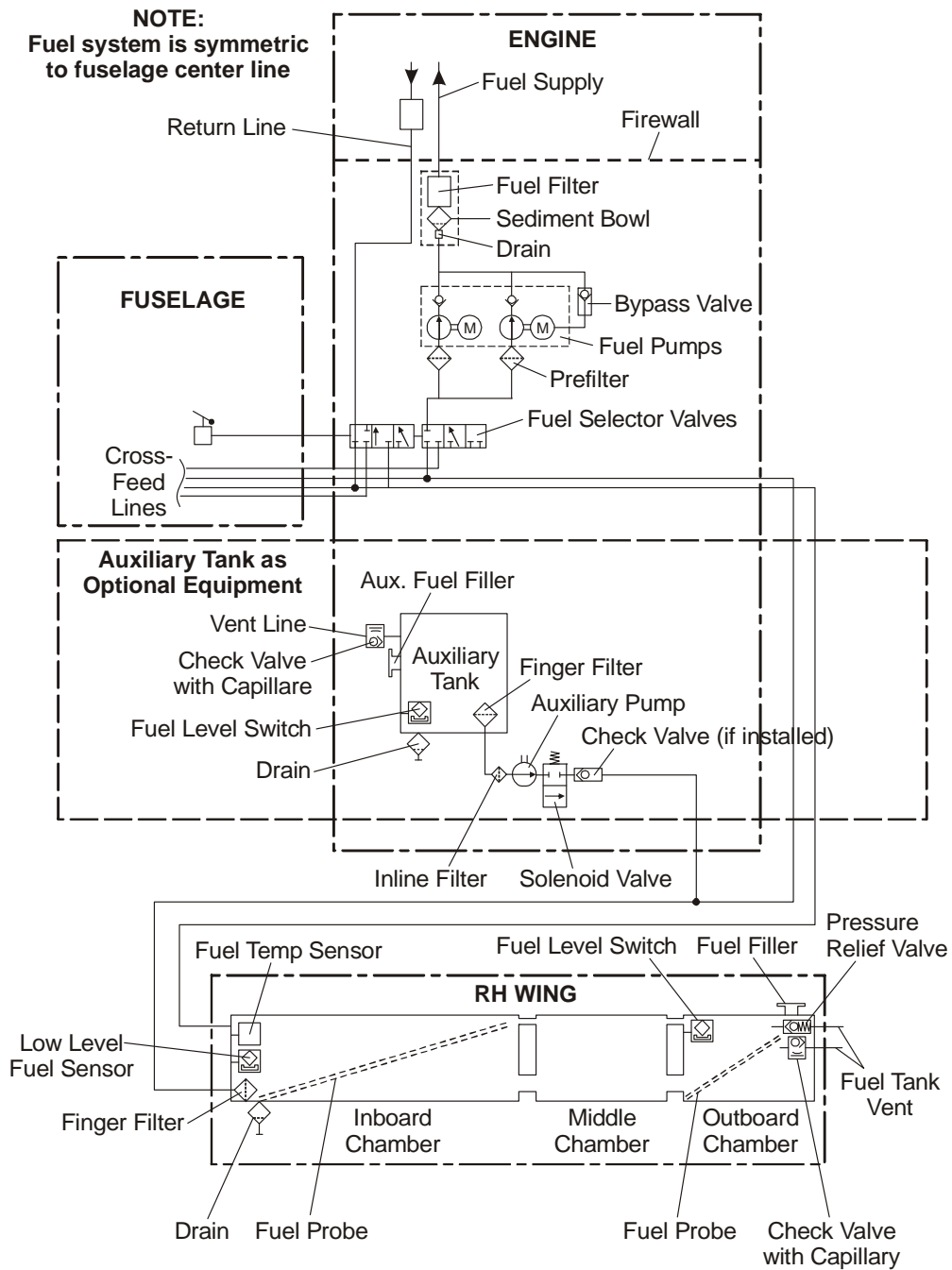

Fuel is stored in the tanks which are located in the wings.

Normally fuel for the right engine is taken from the right wing main tank and for the left engine from the left wing main tank.

On each engine fuel is injected with high pressure directly into the cylinders. The injection nozzles (one per cylinder) are supplied with fuel by the common rail. Pressure inside the rail is generated by a high pressure pump which receives fuel from two independent low pressure fuel pumps. Both pumps are powered electrically. Depending on the power setting the rail pressure is controlled by the ECU through an electric metering valve. Fuel that is not injected is fed back into the appropriate wing tank.

Both sides of the fuel system are interconnected by crossfeed lines.

In each engine nacelle an auxiliary fuel tank may be installed.

Fuel Pumps

Each engine is feed by two parallel installed independent electrically driven low pressure fuel pumps. During normal operation one of the two fuel pumps is working. In case of a low fuel pressure failure the ECU switches automatically to the second fuel pump. During landing and take-off, or in case of a fuel pressure failure both fuel pumps can be activated by the FUEL PUMP switch. If both fuel pumps are activated the fuel pressure increases.

Each fuel pump is electrically connected to the LH/RH ECU BUS and protected by a 7.5 A circuit breaker.

NOTE

By switching between ECU A and B the two independent electrically driven fuel pumps are switched over as well. In case of an emergency both pumps can be activated simultaneously by using the fuel pump switch.

Fuel Selector Valves

For each engine one fuel selector valve is provided. The control levers for the fuel selector valves are situated on the center console behind the power levers. The positions are ON, CROSSFEED and OFF. During normal operation each engine takes the fuel from the tank on the same side as the engine. Before crossfeed operation check fuel pump is OFF. When CROSSFEED is selected, the engine will draw fuel from the tank on the opposite side in order to extend range and keep fuel weight balanced during single engine operation. With the fuel selector valve both the feeding and the return line are switched.

The desired position is reached by pulling the lever back. To reach the OFF position a safety guard must be twisted. This is to ensure that this selection is not made unintentionally.

NOTE

If one engine is inoperative the fuel selector valve for this engine must be in the OFF position.

CAUTION

Do not operate with both fuel selector valves in crossfeed position. Do not take-off with a fuel selector valve in crossfeed position.

CAUTION

Do not shut down an engine with the fuel selector valve. The high pressure fuel pump can be damaged.

Scheme of the Fuel Selector Valve Positions:

Possible operating modes of the three fuel selector valve positions are outlined systematically in the following scheme. The figures below show fuel flows for the RH engine (fuel flows LH are alike):

With the LH fuel selector valve in crossfeed position, the fuel from the RH tank is transferred to the LH engine. Depending on the position of the RH fuel selector valve, the RH tank then feeds both engines (as shown in Figure 4 below) or only the LH engine, when the fuel selector valve of the RH engine is in shut-off position (as shown in Figure 5 below).

Figure 1: Normal Operation.

Figure 2: Crossfeed Operation.

Figure 3: Shut-off.

Figure 4: Fuel selector valve RH normal operation position, fuel selector valve LH crossfeed position.

Figure 5: Fuel selector RH valve shut-off position, fuel selector valve LH crossfeed position.

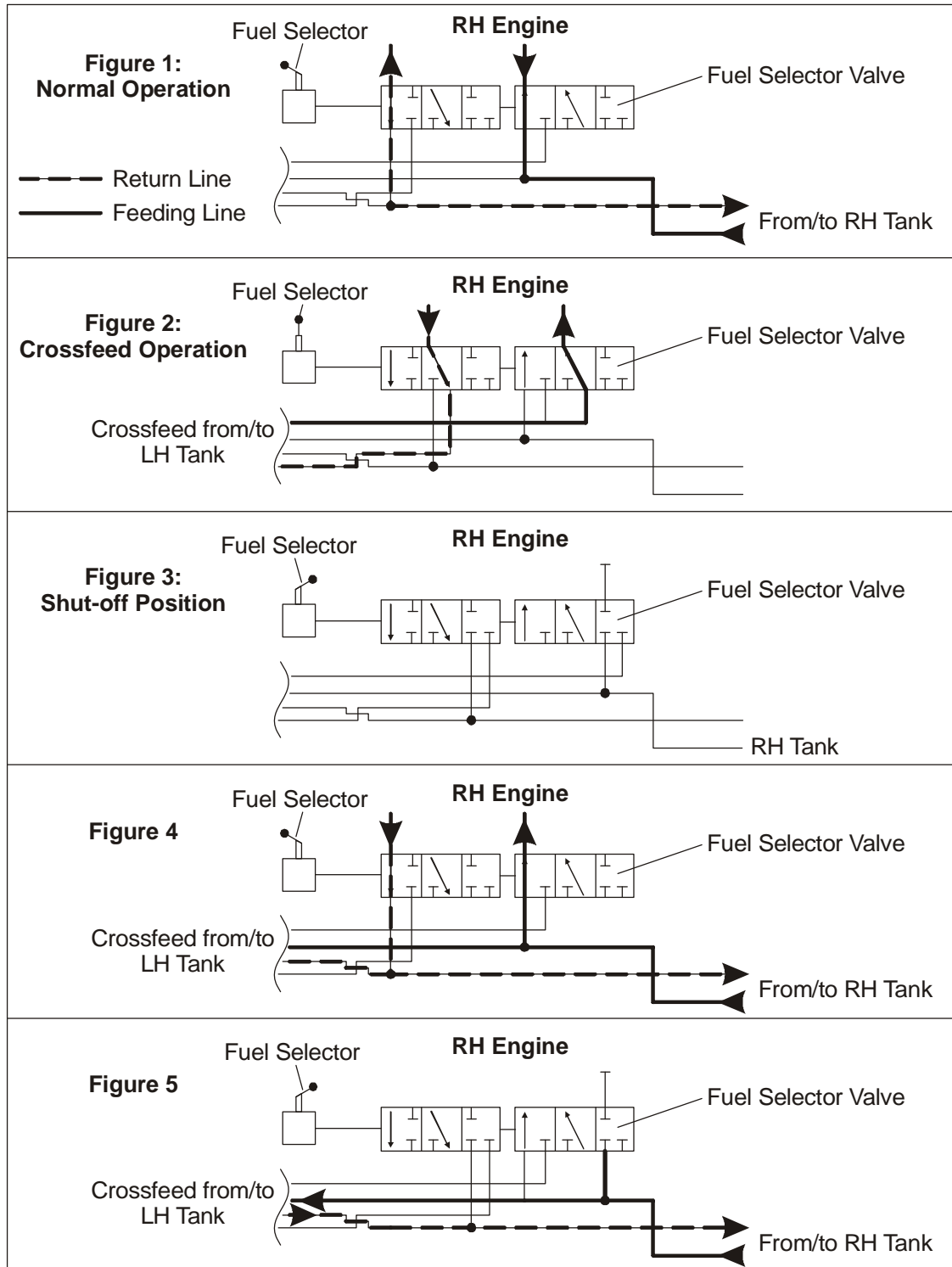

Main Fuel Tanks

Each tank consists of three aluminum chambers which are connected by a flexible hose. The tank is filled through a filler in the outboard fuel chamber. Only four liters (1 US gal) of fuel in each wing are unusable, so that a total quantity of 96 liters (25.4 US gal) in each wing is usable.

There are two tank vents. One includes a check valve with a capillary and one includes a pressure relief valve (bleed type), which operates at 150 mbar (2 PSI) and allows fuel and air to flow to the outside with higher internal pressure. The pressure relief valve protects the tank against high pressure, if the tank was overfilled in case of an auxiliary fuel transfer failure. The check valve with capillary allows air to enter the tank but prevents flow of fuel to the outside. The capillary equalizes the air pressure during climb. The hose terminals are located on the underside of the wing, approximately 2 meters (7 ft) from the wing tip.

In each tank a coarse filter (finger filter) is fitted before the outlet. To allow draining of the tank, a drain valve is located at the lowest point of the fuel tank.

At the lowest point on each side of the fuel system a fuel filter with a drain valve is installed. This drain valve can be used to remove water and sediment which has collected in the fuel system. The drain valves are fitted in each nacelle behind the firewall, approximately 15 cm (0.56 ft) backward of the wing leading edge.

Fuel Quantity Indication

Two capacity probes measure the fuel quantity in each main tank. The indication is provided by the G1000 flight display. Information about fuel consumption can be found in Chapter 5 - PERFORMANCE.

Auxiliary Fuel Tanks (if installed)

The auxiliary fuel tanks are optional equipment (OÄM 42-056).

Description

The auxiliary fuel tanks are installed in the rear section of the engine nacelles, above the wing main spars. Each auxiliary fuel tank has a filler cap located on the top surface of the nacelle. The additional fuel capacity is 13.7 US gallons (52 liters) per side. The total fuel capacity (main fuel tanks and auxiliary fuel tanks) is 39.7 US gallons (150.4 liters) per side.

The fuel supply connection attaches to a finger filter mounted at the rear of the auxiliary fuel tank. Each auxiliary fuel tank has a auxiliary pump which transfers fuel into the related main fuel tank.

The vent line for the auxiliary fuel tank has a check valve with capillary. It allows air to enter the tank but prevents flow of fuel to the outside. The capillary equalizes the air pressure during climb. A fuel drain valve is located at the rear of each auxiliary tank.

Operation

Two AUX PUMP switches in the cockpit are used to activate the auxiliary pumps. The switches are located behind the elevator trim wheel on the center console. Both auxiliary pumps are intended to be used simultaneously to prevent the airplane from additional lateral imbalance. Switch on the auxiliary pumps separated by 10 seconds to prevent the fuse from being tripped by increase starting currents. The auxiliary pump transfers the fuel from the auxiliary fuel tank into the related main fuel tank. The fuel level switch shuts off this pump automatically when the auxiliary fuel tank is empty or when the main fuel tank is full. During operation of the pumps an advisory alert on the Garmin G1000 indicates that the fuel transfer is in progress.

If the auxiliary fuel tank is empty, a caution alert appears on the Garmin G1000. In this case the auxiliary pumps must be switched OFF.

When one auxiliary pump is defective, the fuel stored in the related auxiliary fuel tank is not available. For use of the remaining fuel pump refer to Section 4B.12 - L/R FUEL TRANSFER FAIL. The flight plan must be amended accordingly.

The auxiliary pumps are electrically connected to the LH MAIN BUS and protected by a 5A circuit breaker, if no ice protection system (OÄM 42-053) is installed.

If the ice protection system is installed, both systems are protected by a 10 A circuit breaker and an additional 7A fuse for the auxiliary pumps. The circuit breaker is labeled XFER PUMP/DE ICE.

*Alternate Means for Fuel Quantity
Indication for the Fuel Tank:*

The alternate means for fuel quantity indication allows the fuel quantity in the tank to be determined during the preflight inspection. It functions according to the principle of communicating containers. The fuel quantity measuring device has a recess which fits the airfoil of the wing in front of the fuel tank drain, which lies approximately 10 cm (4 in) outboard of the engine nacelle. The metal connector is pressed against the drain of the tank. The amount of fuel in the tank can now be read off from the vertical ascending pipe.

For an exact indication the airplane must stand on level ground and the measuring device must be held vertically.

The designated location for the fuel quantity measuring device is a bag on the rear side of the pilot seat.

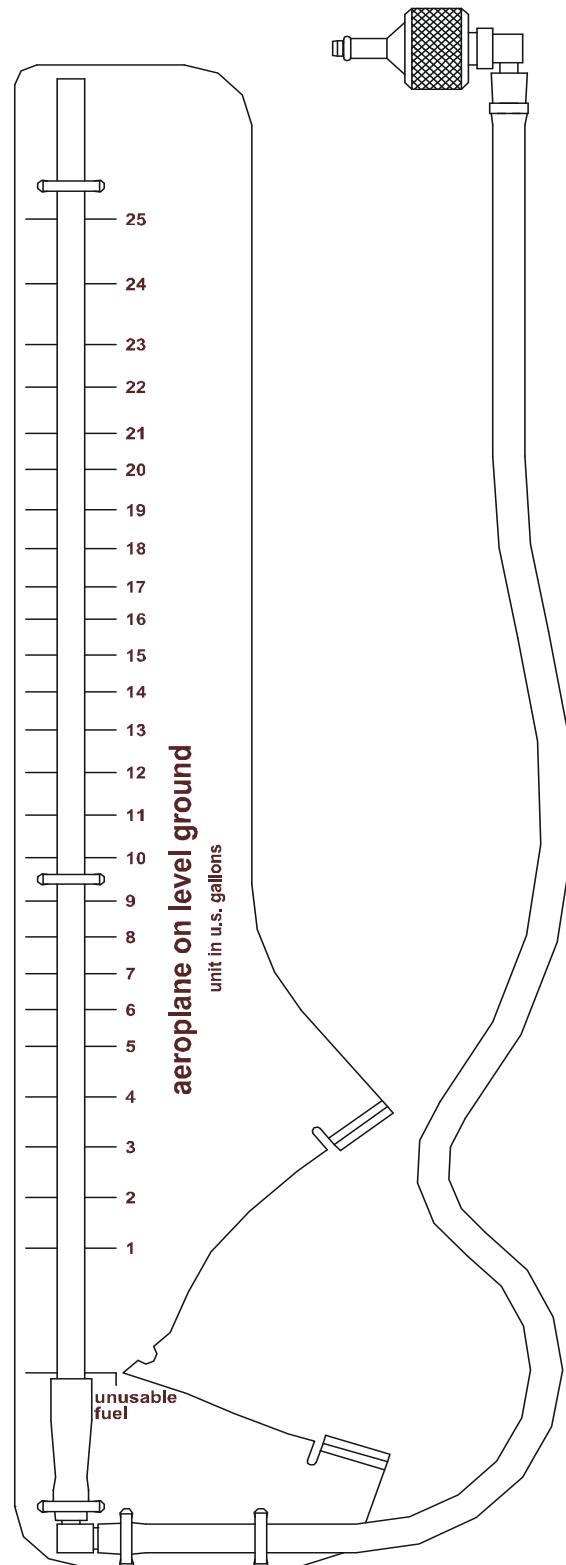

▮ Alternate Means II for Fuel Quantity Indication for the Fuel Tank:

▮ For an exact indication the airplane must stand on horizontal ground with the wings level.

▮ The fuel indicator II includes a protractor for an additional pitch angle measurement. The fuel indicator II is placed on the LH nose baggage compartment floor. The lower edge of the fuel indicator II must be supported by the nose baggage compartment for the entire length. Read and record the pitch angle.

▮ *Standard Tanks:*

▮ Unfold the fuel indicator II and center it at the nose of wing. Read the fuel level on the scale and refer to the tables provided in order to determine the exact fuel quantity.

▮ *Auxiliary Tanks (if installed):*

▮ Unfold the fuel indicator II and place it on the trailing edge of the center wing. Read the fuel level on the scale and refer to the tables provided in order to determine the exact fuel quantity.

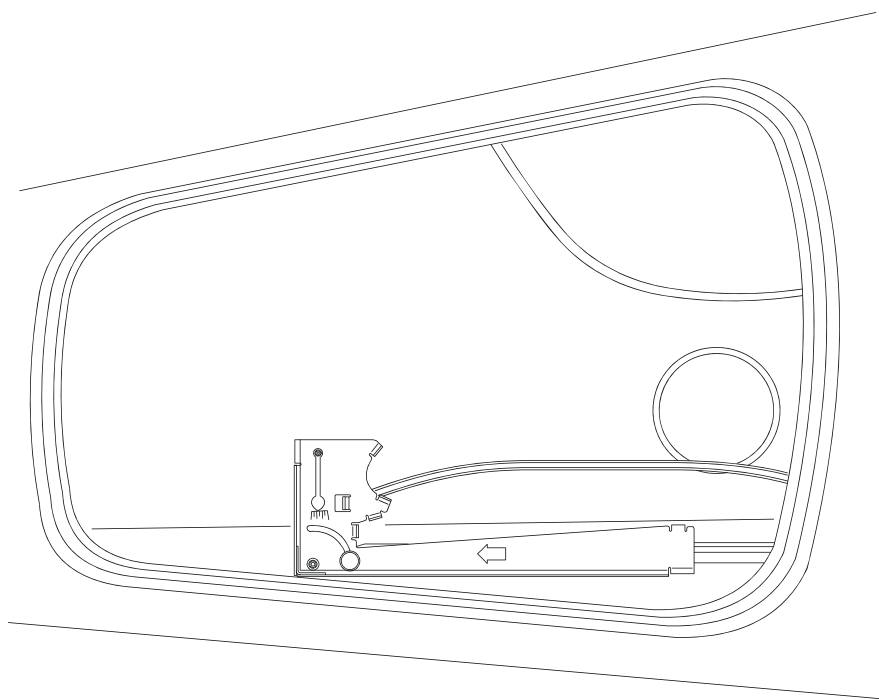

Fuel Quantity Indicator II, Pitch Angle Measurement in Baggage Compartment

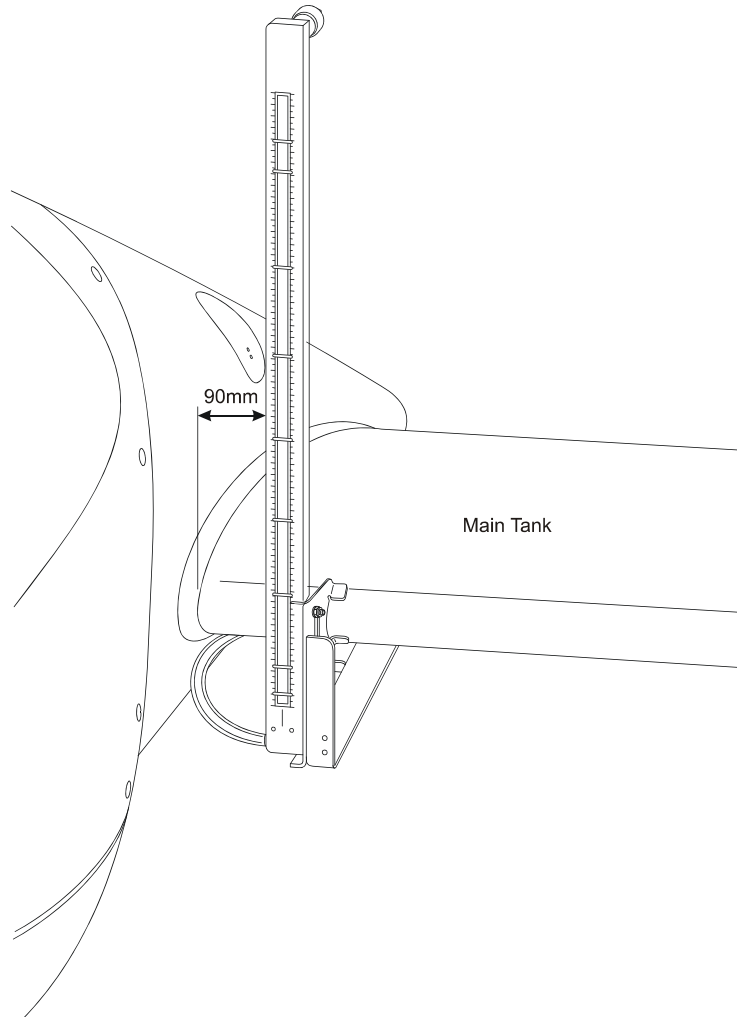

Fuel Quantity Indicator II, Main Tank

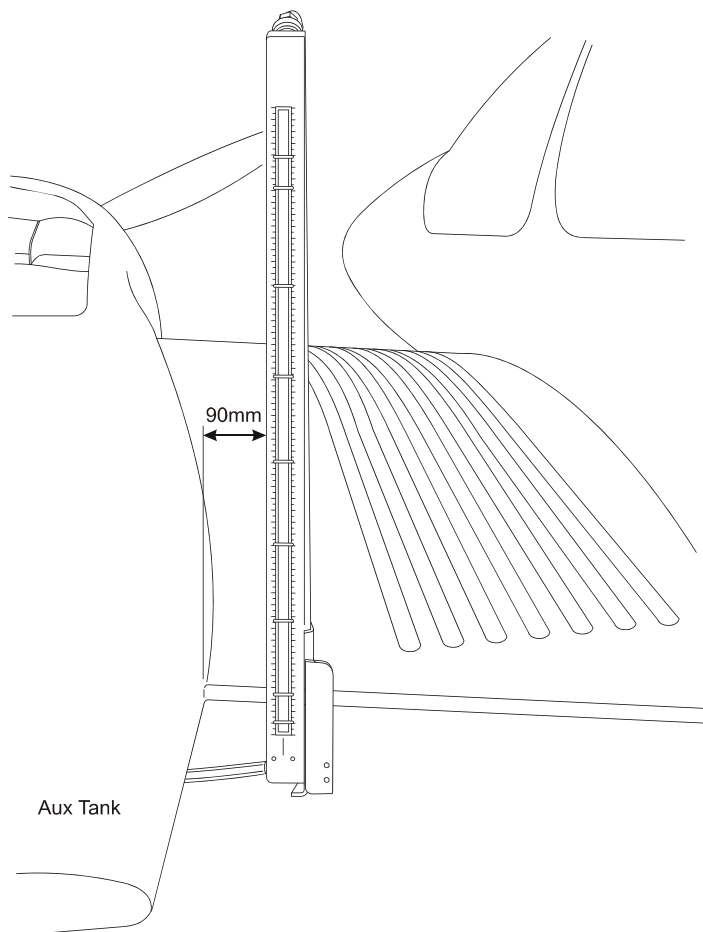

Fuel Quantity Indicator II, Aux Tank

Standard Tank Configuration

Fuel Quantity Indicator II: Pitch Angle Reading						Usable Fuel Quantity	
0°	1°	2°	3°	4°	5°	US gal	Liter
120	112	103	97	90	80	1	3.8
132	128	117	110	102	95	2	7.6
150	141	135	120	116	106	3	11.4
160	147	140	136	128	120	4	15.1
174	165	155	150	140	135	5	18.9
186	175	165	160	149	140	6	22.7
200	185	178	171	160	152	7	26.5
210	198	192	183	175	165	8	30.3
218	210	205	195	184	175	9	34.1
230	225	215	205	198	185	10	37.9
242	230	225	215	209	200	11	41.6
255	245	235	230	222	212	12	45.4
260	255	250	244	232	225	13	49.2
278	270	260	254	243	235	14	53.0
289	280	271	263	255	244	15	56.8
300	290	284	275	270	260	16	60.6
314	308	296	290	285	275	17	64.4
328	321	310	305	298	287	18	68.1
340	334	325	319	310	304	19	71.9
358	342	336	328	320	312	20	75.7
368	360	350	344	335	326	21	79.5
380	372	364	357	347	336	22	83.3
391	385	378	370	361	355	23	87.1
415	408	398	388	380	372	24	90.8

Aux Tank (if installed) Configuration

Fuel Quantity Indicator II: Pitch Angle Reading						Usable Fuel Quantity	
0°	1°	2°	3°	4°	5°	US gal	Liter
120	112	103	97	90	80	1	3.8
132	128	117	110	102	95	2	7.6
150	141	135	120	116	106	3	11.4
160	147	140	136	128	120	4	15.1
174	165	155	150	140	135	5	18.9
186	175	165	160	149	140	6	22.7
200	185	178	171	160	152	7	26.5
210	198	192	183	175	165	8	30.3
218	210	205	195	184	175	9	34.1
230	225	215	205	198	185	10	37.9
242	230	225	215	209	200	11	41.6
255	245	235	230	222	212	12	45.4
260	255	250	244	232	225	13	49.2
278	270	260	254	243	235	14	53.0
289	280	271	263	255	244	15	56.8
300	290	284	275	270	260	16	60.6
314	308	296	290	285	275	17	64.4
328	321	310	305	298	287	18	68.1
340	334	325	319	310	304	19	71.9
358	342	336	328	320	312	20	75.7
368	360	350	344	335	326	21	79.5
380	372	364	357	347	336	22	83.3
391	385	378	370	361	355	23	87.1
415	408	398	388	380	372	24	90.8

Fuel Temperature

Max. fuel temperature: 60 °C (140 °F)

Fuel Grade

Approved fuel grades are listed in Section 2.14 - FUEL.

NOTE

In order to provide information about the fuel grade it is recommended to enter the fuel grade in the airplane log each time fuel is refilled.

7.9.6 COOLING SYSTEM

Each engine is liquid cooled. The liquid cooling system consists of a radiator (coolant heat exchange) and a bypass to this radiator. The bypass is in operation when coolant temperatures are low. It therefore allows the engine to warm-up quickly. Upon reaching a certain temperature (approximately 88 °C or 190 °F) the radiator is activated by a thermostatic valve. Additionally a coolant to air heat exchanger is provided for the cabin heat system. The flow through the heat exchanger is independent of the coolant temperature. An expansion tank helps to adjust the pressure in the system. The system is protected against overpressure by means of a pressure relief valve.

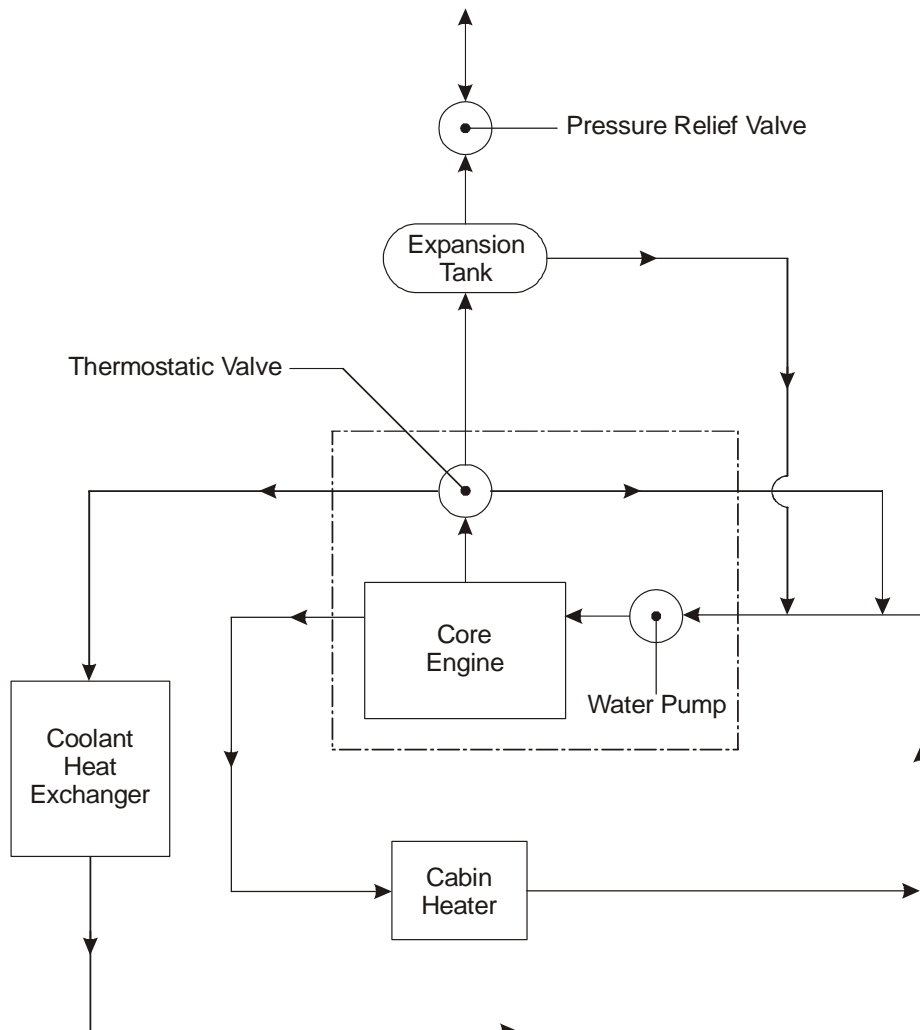

7.9.7 OIL SYSTEMS

Each engine has two separate oil systems.

Lubrication System (Engine and Turbo-Charger)

The engine lubrication is a wet sump lubrication system. The oil is cooled by a water/oil-cooler on the upperside of the engine.

A dip-stick is provided to check the oil quantity through an inspection hole in the left cowling. If required, oil can also be filled in there (for approved oil grades refer to Section 2.4 - POWER-PLANT LIMITATIONS).

Gearbox and Propeller Governor System

The second oil circuit lubricates the gearbox and serves the governor system and the regulation of the propeller.

The gearbox oil quantity can be checked with the help of an inspection glass which can be reached through an inspection hole on the left side of the cowling.

CAUTION

If the gearbox oil quantity is too low, an unscheduled maintenance is necessary (for approved oil grades refer to Section 2.4 - POWER-PLANT LIMITATIONS).

7.9.8 TURBO-CHARGER SYSTEM

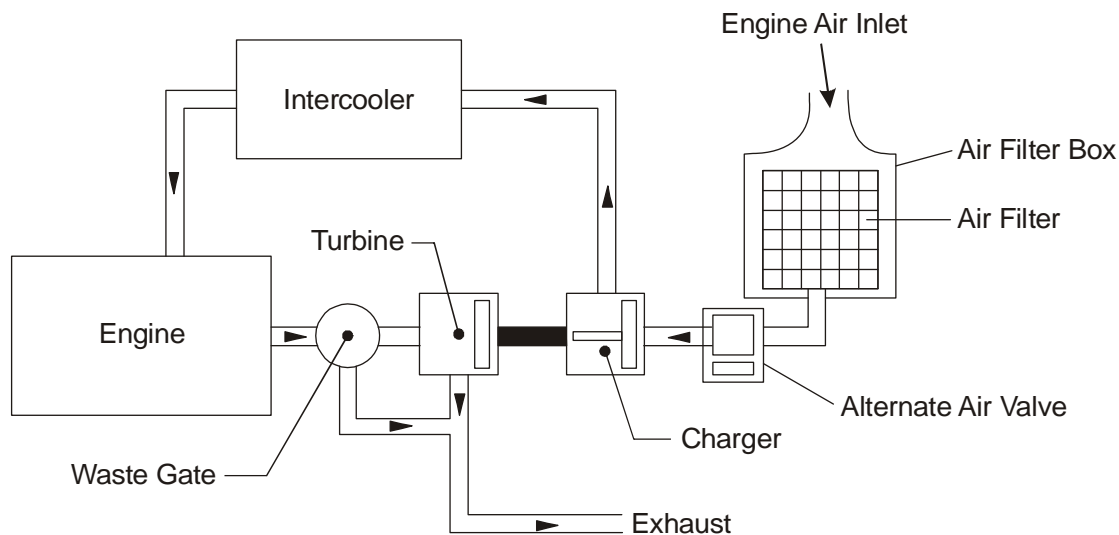

The exhaust system contains a manifold which collects exhaust gases from the outlets of the cylinders and feeds them to the turbine of the turbo charger. Behind the turbine the exhaust gases are guided through the lower cowling to the exterior of the airplane. Excess exhaust gases bypass the turbine. The bypass is controlled by the ECU through the waste gate valve. A manifold pressure sensor behind the compressor allows the ECU to calculate the correct position of the waste gate valve. This prevents excessive manifold pressures at low density altitudes. The intake air is compressed in the compressor which is driven by the turbine, and is subsequently cooled down in the intercooler to increase power. Cooling the air increases efficiency through the higher density of the cooler air.

7.9.9 FIRE DETECTION SYSTEM

The fire detection system in the DA 42 NG consists of an overheat detector in the hot area of each engine. In case of an increase of the engine compartment temperature above 250 °C (480 °F) the overheat detector closes the electric circuit and a warning message appears in the annunciation window of the G1000 PFD.

To test the fire detectors (refer to Section 4A.6.1 - PREFLIGHT INSPECTION) push the test button located next to the gear selector switch. An aural alert and the fire warning message for the LH and RH engine should appear in the annunciation window of the G1000 PFD.

CAUTION

If the warning does not appear, an unscheduled maintenance is necessary.

7.10 ELECTRICAL SYSTEM

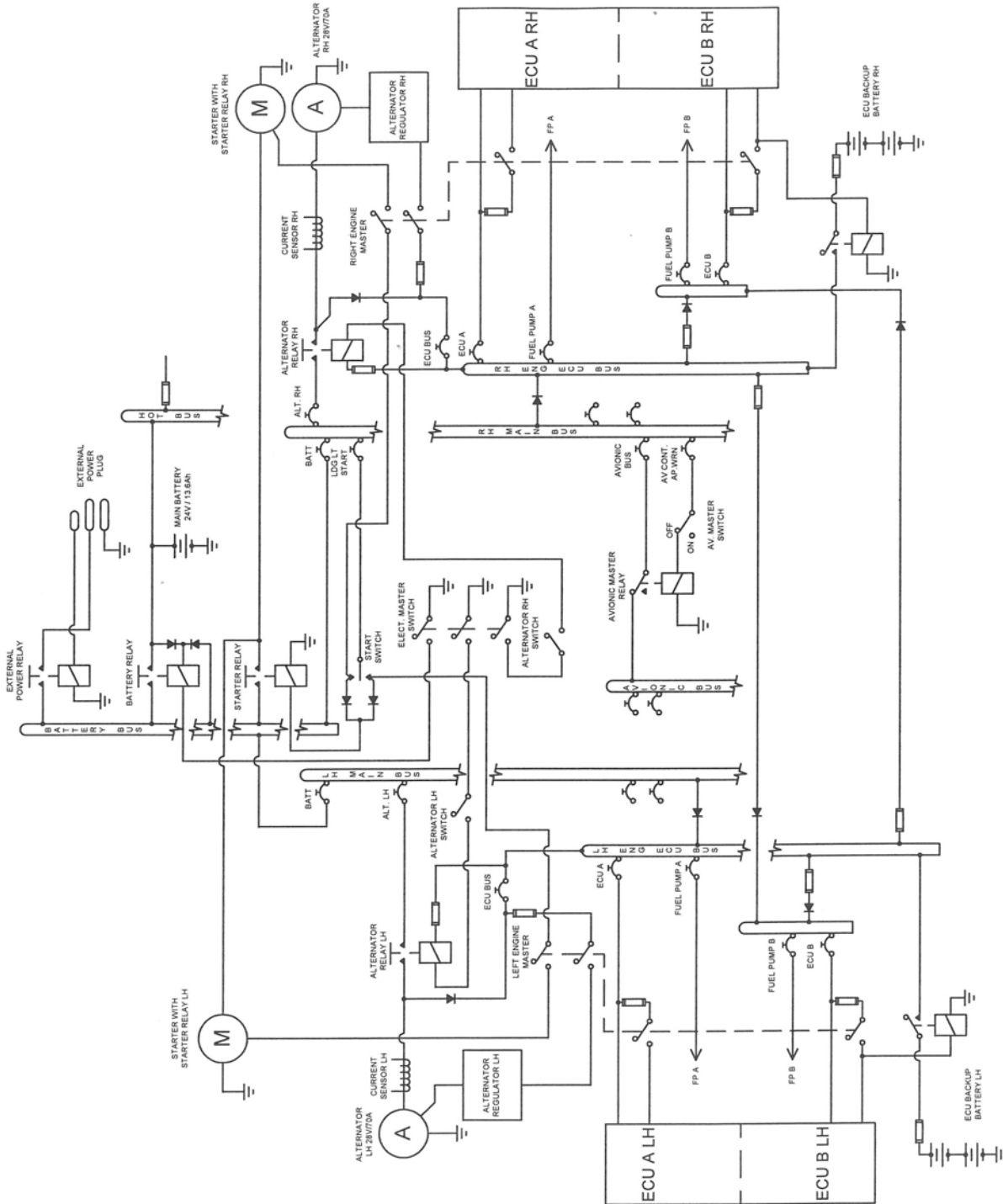

7.10.1 GENERAL

The DA 42 NG has 28 Volt DC system, which can be sub-divided into:

- Power generation
- Storage
- Distribution
- Consumers

Power Generation

Power generation is provided by two 70 Ampère alternators (generators) which are mounted on the bottom left side of each engine. The alternators are driven by a flat belt.

The power output line of the left hand alternator is connected to the LH MAIN BUS via the LH alternator relay and a 60 Ampère circuit breaker. The power output line of the RH alternator is connected to the RH MAIN BUS via the RH alternator relay and a 60 Ampère circuit breaker. Both main busses are connected to the BATTERY BUS via a 90 Ampère circuit breaker.

Both generator power output lines also run through a current sensor for each alternator, which provides an indication of the power being supplied to the electrical system by an alternator including the current for battery charging on the G1000. In the event of a main battery failure the field of each alternator is energized by two 12 V, 7.2 Ah sealed lead acid batteries (ECU backup battery) connected in series, which are installed under the passengers' seats. The ECU backup batteries provide also electrical power for the ECU for a time of 30 minutes (condition).

The ENGINE MASTER LH (RH) switches connect the ECU backup battery to the alternator field via a 10 Ampère fuse.

Alternator Control:

Each alternator has an alternator control unit. It measures the alternator output voltage and controls the current through the alternator field coils via a pulse-width modulated signal. To keep the output voltage stable in all load and speed situations, the alternator field signal is modulated accordingly.

The left alternator regulator also measures the power output of both (LH and RH) alternators via separate current sensors. Based on the current measurements, the LH alternator regulator controls the output of its associated alternator, providing paralleling between the alternators.

The alternator control unit includes a comprehensive set of diagnostic functions that will warn the operator using a caution message (L/R ALTN FAIL) on the G1000 PFD in case of over- or undervoltage as well as a couple of other internal warning levels.

Storage

Main battery power is stored in a 24 V, 13.6 Ah lead-acid battery mounted on the right-aft side of the front baggage compartment. The main battery is connected to the HOT BATTERY BUS and to the BATTERY BUS via the 'battery'-relay which is installed in the relay junction box on the center-aft side of the front baggage compartment.

The battery relay is controlled with the ELECT. MASTER switch which is located on the left-hand side of the instrument panel.

In addition, a non-rechargeable dry battery is installed as a further source of power for the backup attitude gyro (artificial horizon or standby attitude module) and the flood light. When the EMERGENCY switch is set to ON, these two systems are supplied with power for at least 1.5 hours, independent of all other electrical consumers. During each 100 hour inspection, this battery is checked for proper functioning. Every 2 years or after use (broken seal on the switch) the battery package must be replaced.

Distribution

Electrical power is distributed via the HOT BATTERY BUS, the BATTERY BUS, the LH (RH) ECU BUS, the LH (RH) MAIN BUS, and the AVIONIC BUS.

HOT BATTERY BUS:

The HOT BATTERY BUS is directly connected to the main battery and cannot be disconnected from the main battery. The HOT BATTERY BUS provides power to the pilot map/reading light and ELT RCPI unit which are protected by their own fuses.

BATTERY BUS:

The BATTERY BUS is connected to the main battery via the battery relay which can be controlled by the ELECT. MASTER switch. The BATTERY BUS provides power to the LH (RH) MAIN BUS and heavy duty power to both starters.

ECU BUS:

The LH (RH) ECU BUS is connected to the LH (RH) MAIN BUS via a diode and connected to the power output line of the alternator via diode and a 30 Ampère circuit breaker and provides power directly to ECU A and its fuel pump. ECU B and its fuel pump derive their electrical power from their associated ECU BUS via an additional diode and fuse.

Additionally, each ECU B and its fuel pump is supplied with electrical power from the opposite engine side ECU BUS via a diode and fuse.

The LH (RH) ENGINE MASTER switch must be set to ON to activate the engine EECU.

To support the alternator electrical power supply to the ECUs in case of a malfunction of the main battery, additional sealed-lead-acid batteries (ECU backup battery) are connected to the RH and LH ECU bus.

These batteries are able to provide 30 minutes of engine operation in case of a complete airplane electrical failure. Both engines may stop if the 30 minutes have elapsed.

MAIN BUS:

The LH (RH) MAIN BUS is connected to the BATTERY BUS via a 90 Ampère circuit breaker. The LH MAIN BUS provides power to the consumers directly connected to the LH MAIN BUS. The RH MAIN BUS provides power to the consumers directly connected to the RH MAIN BUS and the AVIONIC BUS via the avionics master relay.

The AVIONIC MASTER switch must be set to ON to connect the RH MAIN BUS to the AVIONIC BUS.

Consumers

The individual consumers (e.g. radio, position lights, etc.) are connected to the appropriate bus via automatic circuit breakers.

Designations and abbreviations used to identify the circuit breakers are explained in Section 1.5 - DEFINITIONS AND ABBREVIATIONS.

Voltmeter

The voltmeter displays the voltage of the electrical system. Under normal operating conditions the alternator voltage is shown, otherwise it displays the main battery voltage.

Ammeter

The ammeter displays the intensity of current which is supplied to the electrical system by the LH (RH) alternator.

Landing and Taxi Lights

Landing and taxi lights are built into the wing center section, and are each operated by means of a switch (LANDING, TAXI) located on the row of switches on the instrument panel.

Position and Strobe Lights

Combined position and strobe lights (anti collision lights) are installed on both wing tips. Each system is operated by a switch (POSITION, STROBE) located on the row of switches on the instrument panel.

Flood Light

A two-dimensional light emitter is mounted above the instrument panel. It illuminates the instrument panel as well as all levers, switches, etc. The flood light is switched on and its brightness is adjusted by means of a rotary button (FLOOD) in the LH section of the instrument panel.

Instrument Lighting

With a rotary button (INSTRUMENT) in the LH section of the instrument panel the internal lighting of the instruments is switched on and its brightness is adjusted.

Pitot Heating

The Pitot probe, which provides measurement for the Pitot-static system, is electrically heated. The heating is activated with a switch (PITOT HEAT) located on the row of switches on the instrument panel. The temperature is automatically kept constant by means of a thermal switch on the Pitot probe, and as an additional safety measure a thermal fuse is built in. If this thermal fuse is activated, the Pitot heating can no longer be switched on, and the PITOT FAIL will be displayed. In this case the system should be serviced. The PITOT HT OFF is on if the Pitot heating is switched off.

External Power Socket

The DA 42 NG has an external 28 Volt DC power socket located on the lower surface of the fuselage nose section. When external power is connected, the control relay is energized and the external power comes online.

The socket itself has three pins:

- a large negative pin
- a large positive pin
- a small positive pin

A diode protects the system from reverse polarity.

USB Charging Ports

If MÄM 42-1035 is installed, single USB charging ports are installed on the bottom of the instrument panel on the pilot's and co-pilot's side. The USB charging ports are an accessory that converts the DC electrical power from the aircraft to standard 5 V power for any electronic product that charges using a USB connector. Each USB port provides one Universal Serial Bus-A port, capable of providing up to 3.0 A.

7.10.2 ELECTRONIC ENGINE CONTROL UNIT / ECU

Engine Control and Regulation

The electronic ECU is used to control the engine actuators (e.g. fuel injectors) according to the engine sensor information. The ECU monitors, controls and regulates all important parameters for engine operation.

Sensors installed are:

- Oil temperature (lubrication system engine) / OIL TEMP
- Oil pressure (lubrication system engine) / OIL PRES
- Coolant temperature / COOLANT TEMP
- Gearbox temperature / GEARBOX
- Camshaft RPM (twice)
- Crankshaft RPM (twice)
- Fuel pressure in the common rail
- Manifold pressure
- Manifold air temperature
- Ambient air pressure
- Propeller governor / oil pressure
- Power lever position (twice)
- Voltage
- Starter switch signal
- Fuel pressure
- VOTER switch signal
- ECU TEST switch signal

In accordance with the received signals and a comparison with the programmed characteristic diagrams the necessary inputs are calculated and transmitted by the following signal lines to the engine:

- Signal for propeller governor pressure valve
- Signal for the rail-pressure regulation valve
- Signal for each of the 4 injection nozzles
- Activation of the glow plugs
- Signal for the waste gate valve

The following alerts are displayed on PFD of the G1000:

- Glow sparks active
- Status ECU A
- Status ECU B

The electronic ECU consists of two ECUs per engine. A VOTER switch is integrated in the electronic ECU and proposes (if set to AUTO) an ECU to control the engine regarding the ECU operating hours or - in case of a failure - the ECU with better engine control capability. If the VOTER switch is set to A or B, the related EECU is forced to control the corresponding engine with ECU A respectively ECU B.

A fault in one of the ECUs is indicated by a caution message on the PFD

(L/R ECU A/B FAIL). Two types of faults are known:

- Faults which lead to a latched caution indication
- Faults which lead to a non-latched indication

In case of a latched caution an unscheduled maintenance is necessary and Austro Engine GmbH has to be informed.

7.10.3 WARNING, CAUTION AND ADVISORY MESSAGES

Crew Alerting System (CAS)

The G1000 crew alerting system (CAS) is designed to provide visual and aural alerts to the flight crew. Alerts are divided into three levels as follows:

WARNING

CAUTION

ADVISORY

Crew alerts will appear in the alerts window on the PFD. In this window warnings will appear at the top, followed by cautions and advisories, respectively. Within the criticality levels, messages will appear from newest (top) to oldest (bottom).

At the low right corner of the display there is a MSG (message) soft key. The MSG key provides two functions in the CAS:

1. Pressing the MSG key acknowledges a new master warning / caution / advisory indication.
2. An additional MSG key press with no master alert indication active will open a pop-up auxiliary flight display (AFD) page that contains information for all active alerts.

This structure allows the crew to scroll through all system alerts if the alerts window overflows. This approach displays the most critical alerts close to the pilot's primary field of view at all times, with the option of allowing lower criticality alerts to overflow and be accessible from the pop-up AFD page/window.

Alert Levels

Level	Text Color	Importance	Audible Tone
Warning	Red	May require immediate corrective action	Warning chime tone which repeats without delay until acknowledged by the crew
Caution	Amber	May require future corrective action	Single warning chime tone
Annunciation Advisory	White		None
Message Advisory	White		None
Safe Operation Annunciation	Green	Lowest	None

Warning Alerts on the G1000

Warning Alerts	Meaning / Cause
L/R ENG TEMP	The annunciation is active when the engine coolant temperature is greater than 105 °C.
L/R OIL TEMP	The annunciation is active when the engine oil temperature is greater than 140 °C.
L/R OIL PRES	The annunciation is active when the engine oil pressure is less than 0.9 bar.
L/R FUEL TEMP	The annunciation is active when the fuel temperature is greater than 60 °C.
L/R GBOX TEMP	The annunciation is active when the gearbox oil temperature is greater than 120 °C.
L/R FUEL PRES	The annunciation is active when the engine fuel pressure is low.
L/R ALTN AMPS	The annunciation is active when the alternator load is greater than 70 Amps.
L/R ENG FIRE	The annunciation is active when an engine fire is detected.
L/R STARTER	This annunciation is used to indicate to the pilot that the starter is engaged when it should not be.
DOOR OPEN	The annunciation is used to indicate to the pilot if the baggage-, canopy- or rear door is open.
POSN ERROR	The annunciation is active when the G1000 will no longer provide GPS based navigational guidance.
ATTITUDE FAIL	The annunciation is active when the display system is not receiving attitude reference information from the AHRS.
AIRSPEED FAIL	The annunciation is active when the display system is not receiving airspeed input from the air data computer.
ALTITUDE FAIL	The annunciation is active when the display system is not receiving altitude input from the air data computer.

Warning Alerts	Meaning / Cause
VERT SPEED FAIL	The annunciation is active when the display system is not receiving vertical speed input from the air data computer.
HDG	The annunciation is active when the display system is not receiving valid heading input from the AHRS.
WARN	This annunciation constitutes a RAIM position warning. The nav deviation bar is removed.

Audible Warning Alerts

Warning Alerts	Meaning / Cause
Landing gear retracted	A warning chime tone which repeats without delay is active when the landing gear is retracted while the flaps move into the LDG position or when the POWER lever is placed in a position below approx. 20 %.

Caution Alerts on the G1000

Caution Alerts	Meaning / Cause
L/R ECU A FAIL or L/R ECU B FAIL	The annunciation is active when a fault in ECU A or ECU B has occurred. In case of minor faults, the annunciation can be reset once by pressing the ECU TEST button for more than 2 seconds. However, the annunciation will re-appear upon the next attempt to start the engine.
L/R FUEL LOW	The annunciation is active when the fuel quantity is below 4 ± 1 US gal usable fuel.
L/R VOLTS LOW	The annunciation is active when bus voltage is less than 25 Volts.
L/R ALTN FAIL	The annunciation is active when the alternator has failed.
L/R COOL LVL	The annunciation is active when engine coolant level is low.
PITOT FAIL	The annunciation is active when the Pitot heater is failed.
PITOT HT OFF	The annunciation is active when the Pitot heat is off.
STAL HT FAIL	The annunciation is active when the stall heater is failed.
STAL HT OFF	The annunciation is active when the stall heater is off.
STICK LIMIT	Control stick limiting system (variable elevator stop) has failed.
L/R AUX FUEL E	This annunciation can only occur when the auxiliary fuel tank system (optional equipment) is installed. The annunciation is active when the L/R auxiliary fuel tank is empty and the AUX PUMP is ON.
INTEG RAIM not available	The annunciation is active when RAIM (Receiver Autonomous Integrity Monitor) is not available.
AHRS ALIGN: Keep Wings Level	The annunciation is active when the AHRS (Attitude and Heading Reference System) is aligning.
CHECK GEAR	Landing gear is not down and locked.

Caution Alerts	Meaning / Cause
DEICE LVL LO	De-icing fluid level is low (if installed).
DEICE PRES HI	De-icing pressure is high (if installed).
DEICE PRES LO	De-icing pressure is low (if installed).

Annunciation Advisory Alerts on the G1000

Advisory Alerts	Meaning / Cause
L/R GLOW ON	The annunciation is active when the glow plugs are powered.
L/R AUXPUMP ON	The annunciation is active when fuel transfer from auxiliary to main tank is in progress (if installed).

Message Advisory Alerts on the G1000

Advisory Alerts	Meaning / Cause
PFD FAN FAIL	The annunciation is active when the PFD fan is inoperative.
MFD FAN FAIL	The annunciation is active when the MFD fan is inoperative.
GIA FAN FAIL	The annunciation is active when the GIA fan is inoperative.

7.11 PITOT-STATIC SYSTEM

Total pressure is measured at the leading edge of a Pitot probe under the left wing. The static pressure is measured through the static ports in the rear fuselage. To protect against dirt and condensation there are filters in the system. The Pitot probe is electrically heated.

With the alternate static valve, the static pressure in the cabin can be used as static pressure source in the event of a failure of the Pitot-static system.

7.12 STALL WARNING SYSTEM

The lift detector of the DA 42 NG is located on the front edge of the left wing below the wing chord line. It is supplied electrically and provides a stall warning, before the angle of attack becomes critical. The stall status is announced to the pilot by a continuous sound in the cockpit.

The lift detector vane, the mounting plate and the complete housing are heated to prevent icing. Heating is engaged together with the Pitot heating.

7.13 GARMIN G1000 INTEGRATED AVIONICS SYSTEM

7.13.1 GENERAL

The Garmin G1000 is a fully integrated flight, engine, communication, navigation and surveillance instrumentation system. This integrated avionics system consists of a primary flight display (PFD), a multi-function display (MFD), an audio panel, an attitude and heading reference system (AHRS), an air data computer (ADC) and the sensors and computers to process flight and engine information for display to the pilot. The system contains dual GPS receivers, dual VOR/ILS receivers, dual VHF communications transceivers, a transponder, and an integrated annunciation system to alert the pilot of certain abnormal conditions.

A remote avionic box is located behind the aft baggage compartment frame. A push-to-talk (PTT) button for the COM portion of the G1000 is mounted on the end of each control stick. There are connection facilities for up to 4 headsets between the front seats.

Refer to the Garmin G1000 Cockpit Reference Guide, P/N 190-00963-() and Garmin G1000 Pilot's Guide for the Diamond DA 42 NG, P/N 190-00962-() for complete descriptions of the G1000 system and operating procedures.

If MÄM 42-978 is installed, refer to the Garmin G1000 NXi Cockpit Reference Guide, P/N 190-02238-() and Garmin G1000 NXi Pilot's Guide for the Diamond DA 42 NG, P/N 190-02237-() for complete descriptions of the G1000 NXi system and operating procedures.

- If MÄM 42-1072 is installed, refer to the Garmin G1000 NXi Cockpit Reference Guide,
- P/N 190-02527-() and Garmin G1000 NXi Pilot's Guide for the Diamond DA 42 NG,
- P/N 190-02526-() for complete descriptions of the G1000 NXi system and operating
- procedures.

NOTE

Near the DME ground station, it can happen under certain adverse conditions that the Bendix/King KN 63 DME loses the direct signal from the ground station and locks onto an "echo". This will result in an inaccurate indication of the distance.

NOTE

During retraction and extension of the landing gear the ADF-indication may be inaccurate.

NOTE

Under adverse meteorological conditions, the WX-500 stormscope may indicate false strikes triggered by interference with airplane systems. Thus, it is recommended to use range settings below 100 NM and carefully verify if the indicated strikes are real. Never use the WX-500 stormscope to penetrate a thunderstorm and avoid by at least 20 NM any thunderstorm activity.

7.13.2 PRIMARY FLIGHT DISPLAY (PFD)

The primary flight display (PFD; see figure below) typically displays airspeed, attitude, altitude, and heading information in a traditional format. Slip information is shown as a trapezoid under the bank pointer. One width of the trapezoid is equal to a one ball width slip. Rate of turn information is shown on the scale above the compass rose; full scale deflection is equal to a standard rate turn. The following controls are available on the PFD (clockwise from top right):

- * Communications frequency volume and squelch knob
- * Communications frequency set knobs
- * Communications frequency transfer button
- * Altimeter setting knob (baro set)
- * Course knob
- * Map range knob and cursor control
- * FMS control buttons and knob
- * PFD softkey buttons, including master warning/caution acknowledgment
- * Altitude reference set knob
- * Heading bug control
- * Navigation frequency transfer button
- * Navigation frequency set knobs
- * Navigation frequency volume and identifier knob



The PFD displays the crew alerting (annunciator) system. When a warning or caution message is received, a warning or caution annunciator will flash on the PFD, accompanied by an aural tone. A warning is accompanied by a repeating tone, and a caution is accompanied by a single tone. Acknowledging the alert will cancel the flashing and provide a text description of the message. Refer to Chapter 3 - EMERGENCY PROCEDURES, Chapter 4B - ABNORMAL OPERATING PROCEDURES, and Section 7.10.3 - WARNING, CAUTION AND ADVISORY MESSAGES.

Advisory messages related to G1000 system status are shown in white and are accompanied by a white flashing ADVISORY alert. Refer to the G1000 Pilot's Guide and Cockpit Reference Guide for descriptions of the messages and recommended actions (if applicable).

Trend vectors are shown on the airspeed and altimeter displays as a magenta line predicting 6 seconds at the current rate. The turn rate indicator also functions as a trend indicator on the compass scale.

The PFD can be displayed in a composite format for emergency use by pressing the DISPLAY BACKUP button on the audio panel. In the composite mode, the full crew alerting function remains, but no map functions are available.

7.13.3 MULTI-FUNCTION DISPLAY (MFD)

The multi-function display (MFD) typically displays engine data, maps, terrain, traffic and topography displays, and flight planning and progress information. The display unit is, nearly identical to the PFD and contains the same controls as previously listed. Additionally the MFD incorporates the controls for the autopilot system.

Engine instruments are displayed on the MFD. Discrete engine sensor information is processed by the Garmin engine airframe (GEA) sub-system. When an engine sensor indicates a value outside the normal operating range, the legend will turn yellow for caution range, and turn red and flash for warning range.

Also refer to Section 7.9.4 - ENGINE INSTRUMENTS.

7.13.4 AUDIO PANEL

The audio panel contains traditional transmitter and receiver selectors, as well as an integral intercom and marker beacon system. The marker beacon lights appear on the PFD. In addition, a clearance recorder records the last 2 ½ minutes of received audio. Lights above the selections indicate what selections are active. Pressing the red DISPLAY BACKUP button on the audio panel causes both the PFD and MFD to display a composite mode.

7.13.5 ATTITUDE AND HEADING REFERENCE SYSTEM (AHRS)

The attitude and heading reference system (AHRS) uses GPS, rate sensors, air data, and magnetic variation to determine pitch and roll attitude, sideslip and heading. Operation is possible in a degraded mode if the system loses any of these inputs. Status messages alert the crew of the loss of any of these inputs. The AHRS will align while the airplane is in motion, but will align quicker if the wings are kept level during the alignment process.

7.13.6 AIR DATA COMPUTER (ADC)

The air data computer (ADC) provides airspeed, altitude, vertical speed, and air temperature to the display system. In addition to the primary displays, this information is used by the FMS and TIS systems.

7.13.7 GWX 68 / GWX 70 WEATHER RADAR

The Garmin GWX 68 and the GWX 70 weather radar system provides information about precipitation conditions ahead of the airplane. The system consists of a combined microwave transmitter and receiver system in the nose cone, mounted to the front baggage compartment bulkhead. The system is connected to the electrical system of the airplane via a circuit breaker on the instrument panel. The processed data of the GWX 68 / GWX 70 system is displayed on the Garmin G1000 MFD. Refer to the Garmin G1000 Pilot's Guide, P/N 190-00962-() or Garmin G1000 NXi (MÄM 42-978) Pilot's Guide, P/N 190-02237-() or Garmin NXi (MÄM 42-1072) Pilot's Guide, P/N 190-02526-() in the latest effective issue for more information.

7.14 AVIONICS

7.14.1 AUTOPILOT SYSTEM

General

The GFC 700 automatic flight control system (AFCS) is a 3 axis autopilot and flight director system which provides the pilot with the following features: altitude preselect and altitude hold (ALT); yaw damper; flight level change with airspeed hold (FLC); vertical speed hold (VS); navigation tracking for VOR (NAV) and GPS (GPS); heading hold (HDG); approach mode and go around (GA) pitch/roll guidance. The system consists of autopilot controls on the multi-function display (MFD), servos with autopilot processing logic, flight director processing logic in the GIAs, a control stick-mounted elevator trim switch, a control stick mounted trim interrupt and autopilot disconnect switch, a control stick mounted CWS (control wheel steering) switch, a power lever mounted GA (go-around) switch, and PFD/MFD-mounted altitude preselect, heading, and course knobs.

The GFC 700 autopilot contains an electric pitch trim system which is used by the autopilot for automatic pitch trim during autopilot operation and by the pilot for manual electric pitch trim when the autopilot is not engaged. The manual electric pitch trim is operated by a split switch on the pilot's control stick.

The GFC 700 autopilot and manual electric trim (MET) will not operate until the system has satisfactorily completed a preflight test. The preflight test begins automatically with initial power application to the autopilot (AVIONIC MASTER switch is set to the ON position).

The following conditions will cause the autopilot to automatically disconnect:

- Electrical power failure
- Internal autopilot system failure
- AHRS malfunction
- Loss of air data computer information

The GFC 700 may be manually disconnected by any of the following means:

- Depressing the red AP DISC button on the pilot's or co-pilot's control stick
- Moving the left (outboard) side of the manual electric trim switch on the pilot's control stick
- Pushing the AP button on the autopilot mode controller when the autopilot is engaged
- Depressing the GA button on the left side of the power lever
- Pulling the AUTOPILOT circuit breaker
- Turning off the AVIONICS MASTER switch
- Turning off the ELECT. MASTER switch

In addition, the CWS (control wheel steering) switch on the pilot's control stick will disconnect the autopilot servos from the airplane flight controls as long as the CWS switch is depressed.

Power to the GFC 700 autopilot and electric trim system is supplied through the AVIONIC MASTER switch and the AUTOPILOT circuit breaker. The AVIONIC MASTER switch can be used as an additional means to disable the autopilot and electric trim system. The red AP DISC switch on the pilot's control stick will interrupt power to the manual electric trim for as long as the switch is depressed.

Loss of instruments or components of the G1000 system will affect the GFC 700 AFCS as follows:

- Loss of the AHRS will cause the autopilot to disconnect. The autopilot and flight director will be inoperative. Manual electric trim will be available.
- Loss of the heading function of the AHRS will result in loss of the HDG mode. If in HDG mode at the time heading is lost, the autopilot will revert to basic roll mode (ROL).

- Loss of the MFD will not cause the autopilot to disconnect, and will remain engaged with limited functionality, but the autopilot cannot be re-engaged after disconnect by the pilot.
- Loss of the PFD will cause the autopilot to disconnect. The autopilot and flight director will be inoperative. Manual electric trim will be available.
- Loss of air data computer information will cause the autopilot to disconnect. The autopilot will be inoperative. The flight director will be available except for air data modes (ALT, VS, FLC). Manual electric trim is available.
- Loss of GIA #1 will cause the autopilot to disconnect. The autopilot, flight director and manual electric trim will be inoperative. Loss of GIA #2 will also prevent autopilot and manual electric trim operation, but flight director will be available.
- Loss of the standby airspeed indicator, standby attitude indicator, standby altimeter, or compass will have no effect on the autopilot.
- Loss of both GPS systems will cause the autopilot and flight director to operate in NAV modes (LOC, BC, VOR, VAPP) with reduced accuracy. Course intercept and station crossing performance may be improved by executing intercepts and station crossings in HDG mode, then reselecting NAV mode.

The GFC 700 automatic flight control system (AFCS) installed in the Diamond DA 42 NG consists of the following components:

- One GDU which contains the following mode control buttons:
 - AP (Autopilot engage/disengage)
 - FD (Flight director on/off)
 - HDG (Heading mode on/off)
 - NAV (Nav mode on/off)
 - APR (Approach mode on/off)
 - ALT (Altitude hold mode on/off)

VS (Vertical speed mode on/off)

FLC (Flight level change mode on/off)

NOSE UP and NOSE DN (Vertical mode reference change)

YD (Yaw damper on/off)

This GDU is installed as the MFD.

- Servos with autopilot processing logic in the pitch, roll, yaw and pitch trim control systems
- Servo mounts and brackets
- Flight director processing logic in the GIAs
- Control stick-mounted manual electric trim (MET) switch (split switch) for pitch trim
- Control stick-mounted trim interrupt and autopilot disconnect switch
- Control stick-mounted CWS (control wheel steering) switch
- Remote-mounted go-around switch (on the left side of the power lever knob)
- PFD/MFD mounted altitude preselect knob (ALT)
- PFD/MFD mounted heading select knob (HDG)

Flight director commands and autopilot modes are displayed on the PFD. Full AFCS functionality is only available with both displays operating, and will disconnect under certain reversionary conditions.

Upon initial system power-up, the system undergoes a preflight test. At the end of the test, the autopilot disconnect tone sounds and the PFT and AFCS annunciations are removed. Successful completion of the preflight test is required for the autopilot and manual electric trim to engage.

Annunciation of the flight director and autopilot modes is shown in the lower status field

of the PFD. In general, green indicates active modes and white indicates armed modes. When a mode is directly selected by the pilot, no flashing of the mode will occur. When automatic mode changes occur, they will be annunciated with a flashing annunciation of the new mode for ten seconds in green. If a mode becomes unavailable for whatever reason, the mode will flash for ten seconds in yellow and be replaced by the new mode in green.

Normal autopilot disconnects are annunciated with a yellow flashing AP on the PFD accompanied by a two second autopilot disconnect tone. Normal disconnects are those initiated by the pilot with the AP DISC switch, the MET switch, the AP button on the MFD mode controller, or the GA button (if ESP / USP is NOT installed). Abnormal disconnects will be accompanied by a red flashing AP on the PFD accompanied by a continuous autopilot disconnect tone. The disconnect tone and flashing alert may be cancelled by pressing the AP DISC switch or the left side of the MET switch.

Refer to the Garmin G1000 Cockpit Reference Guide, P/N 190-00963-(), and Garmin G1000 Pilot's Guide for the Diamond DA 42 NG, P/N 190-00962-(), for complete descriptions of the G1000 system and operating procedures.

If MÄM 42-978 is installed, refer to the Garmin G1000 NXi Cockpit Reference Guide, P/N 190-02238-() and Garmin G1000 NXi Pilot's Guide for the Diamond DA 42 NG, P/N 190-02237-() for complete descriptions of the G1000 NXi system and operating procedures.

■ If MÄM 42-1072 is installed, refer to the Garmin G1000 NXi Cockpit Reference Guide, P/N 190-02527-() and Garmin G1000 NXi Pilot's Guide for the Diamond DA 42 NG, P/N 190-02526-() for complete descriptions of the G1000 NXi system and operating procedures.

Power Supply

The AVIONIC MASTER switch supplies power to the avionics bus bar of the radio circuit breakers and the autopilot circuit breaker.

The following circuit breaker is used to protect the following element of the GFC 700 autopilot:

Circuit Breaker	Function
AUTOPILOT	Supplies power to the autopilot pitch, roll, yaw and pitch trim servos.

7.14.2 AUTOMATIC FLIGHT CONTROL SYSTEM ANNUNCIATIONS AND ALERTS

Automatic Flight Control System (AFCS) Status Alerts

The following annunciations can appear on the PFD above the airspeed and attitude indicators. Only one annunciation occurs at a time, and messages are prioritized by criticality.

Warning Alerts on the Automatic Flight Control System (AFCS)

Warning Alerts	Meaning / Cause
PFT	PREFLIGHT TEST - Preflight system test failed; aural alert sounds at failure.
AFCS	SYSTEM FAILURE - AP and MET are unavailable; FD may still be available.
PTCH	PITCH FAILURE - Pitch axis control failure; AP inoperative.
ROL	ROLL FAILURE - Roll axis control failure; AP inoperative.
YAW	YAW DAMPER FAILURE - Yaw damper control failure; AP inoperative.
PTRM	PITCH TRIM FAILURE (or stuck AP TRIM switch) - if AP engaged, take control of the airplane and disengage AP. If AP disengaged, move AP TRIM switches separately to release.

Caution Alerts on the Automatic Flight Control System (AFCS)

Caution Alerts	Meaning / Cause
↑ELE	ELEVATOR MISTRIM UP - Pitch servo providing sustained force in the indicated direction.
↓ELE	ELEVATOR MISTRIM DOWN - Pitch servo providing sustained force in the indicated direction.
←AIL	AILERON MISTRIM LEFT - Roll servo providing sustained force in indicated direction.
AIL→	AILERON MISTRIM RIGHT - Roll servo providing sustained force in indicated direction.
←RUD	RUDDER MISTRIM LEFT - Yaw servo providing sustained force in the indicated direction.
RUD→	RUDDER MISTRIM RIGHT - Yaw servo providing sustained force in the indicated direction.

Advisory Alerts on the Automatic Flight Control System (AFCS)

Advisory	Meaning / Cause
PFT	PREFLIGHT TEST - Performing preflight system test; aural alert sounds at completion. Do not press the AP DISC switch during servo power-up and preflight system tests as this may cause the preflight system test to fail or never to start (if servos fail their power-up tests). Power must be cycled to the servos to remedy the situation.

7.15 MID CONTINENT MD302 STANDBY ATTITUDE MODULE



The Mid Continent MD302 standby attitude module is a self-contained situational awareness instrument that provides aircraft attitude, altitude, airspeed and slip indication.

The standby attitude module consists of two separate LCD displays. The left display serves as artificial horizon and the right display as airspeed indicator and altimeter. The user interface of the standby attitude module allows for simple, intuitive operation using a single push-and-turn control knob. The MD302 is connected to the airplane's emergency battery which provides power to the standby attitude module for at least 1.5 hour in case of a total electrical failure.

Refer to the Mid Continent MD302 Standby Attitude Module Pilot's Guide, P/N 9017846 in the latest effective issue for more information.

1. The descriptions, procedures and figures (e.g. battery icon) of the internal battery of the MD302 standby attitude module, shown in the Pilot's Guide are not applicable to the DA 42 NG, due to the use of the external emergency battery.
2. The MD302 standby attitude module is not connected to an external ARINC 429 source (Garmin G1000), thus heading information and automatic BARO synchronization is not available in the DA 42 NG.

CHAPTER 8

AIRPLANE HANDLING, CARE AND MAINTENANCE

	Page
8.1 INTRODUCTION	8-2
8.2 AIRPLANE INSPECTION INTERVALS	8-2
8.3 AIRPLANE ALTERATIONS OR REPAIRS	8-3
8.4 SERVICING	8-3
8.4.1 REFUELING	8-3
8.4.2 ENGINE OIL LEVEL CHECK	8-4
8.4.3 GEARBOX OIL LEVEL CHECK	8-4
8.4.4 TIRE INFLATION PRESSURE CHECK	8-5
8.5 GROUND HANDLING / ROAD TRANSPORT	8-6
8.5.1 GROUND HANDLING	8-6
8.5.2 PARKING	8-9
8.5.3 MOORING	8-12
8.5.4 JACKING	8-12
8.6 CLEANING AND CARE	8-13
8.6.1 PAINTED SURFACES	8-13
8.6.2 CANOPY AND REAR DOOR	8-14
8.6.3 PROPELLER	8-14
8.6.4 ENGINE	8-14
8.6.5 INTERIOR SURFACES	8-14
8.7 GROUND DE-ICING	8-15

8.1 INTRODUCTION

Chapter 8 contains the manufacturer's recommended procedures for proper ground handling and servicing of the airplane. The Airplane Maintenance Manual (Doc. No. 7.02.15) lists certain inspection and maintenance requirements which must be followed if the airplane is to retain a new plane performance and reliability.

8.2 AIRPLANE INSPECTION INTERVALS

Inspections are scheduled every 100, 200, 1000 and 2000 hours. Independent of the flight hours an annual inspection must be performed every year. A non-recurring engine inspection must be performed on new engines after 3 to 6 hours. The respective inspection checklists are prescribed in the Airplane Maintenance Manual, Chapter 05.

For maintenance work on engine and propeller, the currently effective Operator's Manuals, Service Instructions, Service Letters and Service Bulletins of Austro Engine and mt-Propeller must be followed. For airframe inspections, the currently effective checklists/manuals, Service Bulletins and Service Instructions of the manufacturer must be followed.

CAUTION

Unscheduled maintenance checks are required after:

- hard landings
- propeller strike
- engine fire
- lightning strike
- occurrence of other malfunctions and damage

Unscheduled maintenance checks are described in the Airplane Maintenance Manual (Doc. No. 7.02.15; Section 05-50).

8.3 AIRPLANE ALTERATIONS OR REPAIRS

Alterations or repairs to the airplane may be carried out only according to the Airplane Maintenance Manual, Doc. No. 7.02.15, and only by authorized personnel.

8.4 SERVICING

8.4.1 REFUELING

WARNING

Do not allow fire, sparks or heat near fuel. Fuel burns violently and can cause injury to persons and damage to the airplane.

WARNING

Do not get fuel on your skin. Fuel can cause skin disease.

WARNING

Connect the airplane and the fuel supply vehicle to electrical ground before refueling. If you do not ground the airplane, static electricity can cause fire during refueling.

WARNING

Make sure that a suitable fire extinguisher is available at all times during refueling.

WARNING

Turn off all ground equipment in the refueling area.

WARNING

Do not operate electrical switches in the airplane during refueling.

CAUTION

Use only approved fuel types given in Chapter 2.

1. Ground the airplane and the fuel supply vehicle electrically.
2. Remove the fuel filler cap (located on top of the outer wing). Check cap retaining cable for damage.
3. Refuel the airplane.
4. Install the fuel filler cap.
5. Repeat steps 2 to 4 for the other wing.
6. Remove the ground cable from the airplane and the fuel supply vehicle.

8.4.2 ENGINE OIL LEVEL CHECK

1. Open the inspection door on the bottom of the upper left cowling.
2. Remove the filler cap.
3. Clean the oil dip-stick.
4. Install the filler cap.
5. Remove the filler cap again.
6. Read the oil level from the dip-stick.
7. If necessary, add engine oil and repeat steps 3 to 6.
8. Install the filler cap.
9. Close the inspection door.
10. Repeat steps 1 to 9 for the other engine.

8.4.3 GEARBOX OIL LEVEL CHECK

1. Open the inspection door on the bottom of the upper left cowling.
2. Check gearbox oil level in inspection window by using a flashlight.
3. Close the inspection door.
4. Repeat steps 1 to 3 for the other engine.

8.4.4 TIRE INFLATION PRESSURE CHECK

1. Remove dust cap from valve stem by turning counterclockwise.
2. Connect tire gauge to valve stem, read pressure.
3. Correct pressure if necessary (nose wheel 6.0 bar/87 PSI, main wheels 4.7 bar/68 PSI).
4. Install dust cap on valve stem by turning clockwise.

8.5 GROUND HANDLING / ROAD TRANSPORT

8.5.1 GROUND HANDLING

To move the airplane on ground, it can be pushed or pulled by hand on the inner section of the propeller blades near the spinner or pushed at the wing nose and at the rough surface of the center wing, inboard of the nacelles. Do not push on the spinners, as you may damage the spinner which can cause vibration and damage to the engine. Do not use force on the propeller tips or on the airplane control surfaces and do not push on the de-icing nozzles (if installed) on the propeller blade root, as you may damage the propeller, the control surfaces or the de-icing nozzles.

It is recommended to use the steering bar or a tow bar which is available from the manufacturer to assist steering and towing. The tow bar is engaged in the appropriate hole in the nosewheel as shown in the figure below.

CAUTION

Do not damage the vortex generators when you push on the center wing.

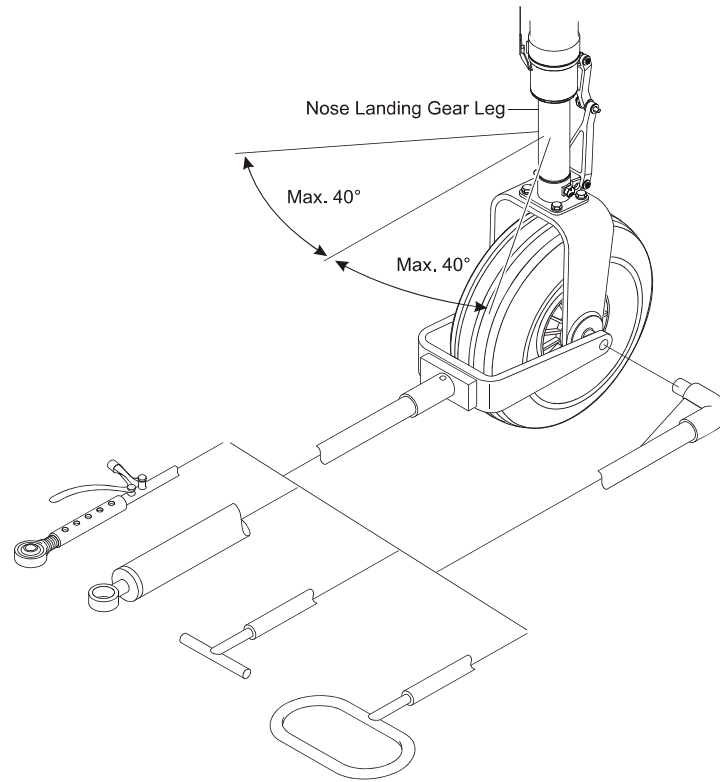

Steering Bar or Tow Bar Attachment

CAUTION

If the airplane is towed by a tow vehicle, do not turn the nose wheel more than 40 degrees to either side from the center position. Otherwise damage to the gear will result.

When towing the airplane with a tow vehicle, a qualified person must sit in the cockpit ready for immediate braking action, in the event that the tow vehicle becomes uncoupled. The movement of the tow vehicle should always be started and stopped slowly to avoid shock loads on the nose landing gear. The maximum steering angle of 40 degrees to either side must not be exceeded.

WARNING

The tow bar must be removed before starting the engine.

If the airplane must be pulled out of soft ground or deep snow, towing lines must be used. The towing lines should be attached to the main landing gear struts as high as possible without interfering with the brake lines. The ropes should be long enough to sufficiently clear the nose or tail. A qualified person must sit in the cockpit to maintain control of the airplane using the nose wheel steering and brakes.

WARNING

All towing lines must be removed before starting the engine.

8.5.2 PARKING

For short term parking, the airplane must be positioned into the wind, the parking brake must be engaged and the wing flaps must be in the retracted position. For extended and unattended parking, as well as in unpredictable wind conditions, the airplane must be anchored to the ground or placed in a hangar. Parking in a hangar is recommended.

Refer to the Airplane Maintenance Manual, Doc. No. 7.02.15, latest revision for necessary parking procedures. Use the short term parking procedure when the airplane will be parked for less than 5 days. Use the long term parking procedure when the airplane will be parked for 5 to 30 days. Use the storage procedure when the airplane will be parked for more than 30 days.

NOTE

If the engine is not used for more than 4 weeks an engine ground run must be performed. Refer to AE Operation Manual, Doc. No. E4.01.01, latest revision.

Control Surfaces Gust Lock

The manufacturer offers a control surfaces gust lock which can be used to block the primary controls. It is recommended that the control surfaces gust lock be used when parking outdoors, because otherwise the control surfaces can hit the stops in strong tail wind. This can lead to excessive wear or damage.

WARNING

The control surfaces gust lock must be removed before flight.

The control surfaces gust lock is installed as follows:

1. Move the rudder pedals fully forward.
2. Engage the control surfaces gustlock with the pedals.
3. Engage the stick, wrap straps around stick once.
4. Attach the locks and tighten the straps.

For removal reverse the sequence.



8.5.3 MOORING

Near the lower end of the tail fin of the airplane there is a hole which can be used to tie down the airplane to the ground. Also on each wing near the wing tip, an eyelet with a metric M8 thread can be installed and used as tie-down points.

8.5.4 JACKING

The airplane can be jacked at the two jackpoints located on the lower side of the center wing's LH and RH root ribs as well as at the tail fin.

8.6 CLEANING AND CARE

CAUTION

The airplane must be kept clean. The bright surface prevents the structure from overheating.

CAUTION

Excessive dirt deteriorates the flight performance.

8.6.1 PAINTED SURFACES

The entire surface of the airplane is painted with a white weatherproof two component paint. Nevertheless, it is recommended to protect the airplane against moisture and dampness. It is also recommended not to store the airplane outside for long periods of time.

Dirt, insects, etc. can be removed with water alone and if necessary with a mild detergent. An automotive paint cleaner can be used for stubborn spots. For best results, clean the airplane after the day's flying is ended, so that the dirt will not become ingrained.

Oil stains, exhaust stains, etc. on the lower fuselage skin can be removed with a cold detergent. Before starting, ensure that the detergent does not affect the surface finish. Use commercial automotive preservatives without silicone additives to conserve the paint finish.

8.6.2 CANOPY AND REAR DOOR

The canopy, rear door and rear window should be cleaned with 'Plexiklar' or any other acrylic glass detergent if available; otherwise use lukewarm water. Final cleaning should be carried out with a clean piece of chamois leather or soft cloth. Never rub or polish dry acrylic glass.

8.6.3 PROPELLER

Damage and malfunctions during operation must be inspected by authorized personnel.

Surface

The manufacturer uses PU paint or acrylic paint which is resistant to almost any solvent. The blades may be treated with commercial automotive cleaning agents or preservatives. The penetration of moisture into the wooden core must be avoided by all means. Should doubts arise, an appropriately rated inspector must be consulted.

8.6.4 ENGINE

Engine cleaning is part of the scheduled inspections.

8.6.5 INTERIOR SURFACES

The interior should be cleaned using a vacuum cleaner. All loose items (pens, bags etc.) should be removed or properly stored and secured.

All instruments can be cleaned using a soft dry cloth. Plastic surfaces should be wiped clean using a damp cloth without any cleaning agents.

The leather interior should be treated with leather sealer within 3 months since new, and then at intervals of 3 to 6 months. Clean the leather interior with an appropriate mild leather cleaning agent and a soft cleaning brush for leather.

Note that the acrylic glass windows transmit the ultraviolet radiation from the sun.

8.7 GROUND DE-ICING

Approved deicing fluids are:

Manufacturer	Name
Kilfrost	TKS 80
Aeroshell	Compound 07
	AL-5 (DTD 406B)

1. Remove any snow from the airplane using a soft brush.
2. Spray deicing fluid onto ice-covered surfaces using a suitable spray bottle.
3. Use a soft piece of cloth to wipe the airplane dry.

Intentionally left blank.

CHAPTER 9 SUPPLEMENTS

	Page
9.1 INTRODUCTION	9-2
9.2 LIST OF SUPPLEMENTS	9-3

9.1 INTRODUCTION

Chapter 9 contains information concerning additional (optional) equipment of the DA 42 NG.

Unless otherwise stated, the procedures given in the Supplements must be applied in addition to the procedures given in the main part of the Airplane Flight Manual.

All approved supplements are listed in the List of Supplements in this Chapter.

The Airplane Flight Manual contains exactly those Supplements which correspond to the installed equipment according to the Equipment Inventory of Section 6.5.

9.2 LIST OF SUPPLEMENTS

Airplane S/N:		Registration:		Date:	
Sup. No.	Title	Rev. No.	Date	applicable	
				YES	NO
A33	Integrated Avionics System Garmin G1000 and G1000 NXi, SBAS and P-RNAV Operation	3	05-Nov-2018	<input type="checkbox"/>	<input type="checkbox"/>
A34	Electronic Stability and Protection (ESP)	0	28-Mar-2014	<input type="checkbox"/>	<input type="checkbox"/>
M00	DA 42 M - NG	2	28-Oct-2019	<input type="checkbox"/>	<input type="checkbox"/>
M01	Belly Pod	0	03-Mar-2015	<input type="checkbox"/>	<input type="checkbox"/>
M05	Universal Nose (STD-TC)	2	28-Oct-2019	<input type="checkbox"/>	<input type="checkbox"/>
M06	Nose Pod (STD-TC)	2	28-Oct-2019	<input type="checkbox"/>	<input type="checkbox"/>
M07	Belly Pod (STD-TC)	1	28-Oct-2019	<input type="checkbox"/>	<input type="checkbox"/>
M09	Geo-Star Pod (Std. TC)	1	21-Apr-2020	<input type="checkbox"/>	<input type="checkbox"/>
M10	Operator Desk	1	20-Apr-2015	<input type="checkbox"/>	<input type="checkbox"/>
M15	On Top Exhaust System	0	03-Mar-2015	<input type="checkbox"/>	<input type="checkbox"/>
Doc. No. 7.01.16-E		Rev. 5	10-Jun-2021	Page 9 - 3	

Airplane S/N:

Registration:

Date:

Sup. No.	Title	Rev. No.	Date	applicable	
				YES	NO
M20	Large Satellite Uplink	0	03-Mar-2015	<input type="checkbox"/>	<input type="checkbox"/>
M30	Universal Nose	2	02-Feb-2018	<input type="checkbox"/>	<input type="checkbox"/>
M40	TerraStar Configuration	0	06-Nov-2017	<input type="checkbox"/>	<input type="checkbox"/>
M60	Nose Pod	1	03-Oct-2016	<input type="checkbox"/>	<input type="checkbox"/>
M62	Geo-Star Pod	1	03-Oct-2017	<input type="checkbox"/>	<input type="checkbox"/>
M160	Nose Pod with Standard Baggage Compartment	1	03-Oct-2017	<input type="checkbox"/>	<input type="checkbox"/>
O04	Operation without Unfeathering Accumulator	0	15-Nov-2013	<input type="checkbox"/>	<input type="checkbox"/>
O05	Diesel Operation	0	06-Dec-2013	<input type="checkbox"/>	<input type="checkbox"/>
O06	MTOM 2001 kg / 4411 lb	0	01-Apr-2014	<input type="checkbox"/>	<input type="checkbox"/>
O07	RH Stick Removal	0	10-Dec-2014	<input type="checkbox"/>	<input type="checkbox"/>
O08	Pilot's Removable Stick	0	30-Jun-2015	<input type="checkbox"/>	<input type="checkbox"/>

Airplane S/N:		Registration:		Date:	
Sup. No.	Title	Rev. No.	Date	applicable	
				YES	NO
O11	Secondary Power Lever	0	28-Jun-2017	<input type="checkbox"/>	<input type="checkbox"/>
S02	Ice Protection System	2	22-Oct-2020	<input type="checkbox"/>	<input type="checkbox"/>
S03	Ice Protection System	8	22-Oct-2020	<input type="checkbox"/>	<input type="checkbox"/>
S04	Continuous Flow Oxygen System	0	01-Apr-2012	<input type="checkbox"/>	<input type="checkbox"/>
S06	G1000 Synthetic Vision Technology	0	01-Apr-2012	<input type="checkbox"/>	<input type="checkbox"/>
S07	Recirculating Cabin - Air Cooling	1	01-Apr-2014	<input type="checkbox"/>	<input type="checkbox"/>
S08	Removal of Variable Elevator Stop	1	01-Apr-2014	<input type="checkbox"/>	<input type="checkbox"/>
S10	Flight Data Logging Device	0	03-Mar-2015	<input type="checkbox"/>	<input type="checkbox"/>
S11	Canopy Jettison System	0	28-Jun-2017	<input type="checkbox"/>	<input type="checkbox"/>
S12	AmSafe Aviation Inflatable Restraint AAIR V23	2	20-Mar-2019	<input type="checkbox"/>	<input type="checkbox"/>
S13	Flight Stream 510	0	31-Jan-2019	<input type="checkbox"/>	<input type="checkbox"/>

Doc. No. 7.01.16-E	Rev. 5	10-Jun-2021	Page 9 - 5
--------------------	--------	-------------	------------



Airplane S/N:		Registration:		Date:	
Sup. No.	Title	Rev. No.	Date	applicable	
				YES	NO
				<input type="checkbox"/>	<input type="checkbox"/>
				<input type="checkbox"/>	<input type="checkbox"/>
				<input type="checkbox"/>	<input type="checkbox"/>
				<input type="checkbox"/>	<input type="checkbox"/>
				<input type="checkbox"/>	<input type="checkbox"/>
				<input type="checkbox"/>	<input type="checkbox"/>
				<input type="checkbox"/>	<input type="checkbox"/>
				<input type="checkbox"/>	<input type="checkbox"/>
				<input type="checkbox"/>	<input type="checkbox"/>